



Istituto Nazionale di Fisica Nucleare
Sezione di Pisa

Largo Bruno Pontecorvo, 56127 Pisa – Italy. <http://www.pi.infn.it>



Advanced Virgo - Suspension Control System

Document Number: VIR-NOT-PIS-4900-151

Issue: 1.0

Date: 24/11/2008

Author: Alberto Gennai



Change Record

<i>Issue</i>	<i>Date</i>	<i>Affected Paragraphs</i>	<i>Reason/Remarks</i>	<i>Author</i>
1.0	24/11/2008	All	First issue	A. Gennai

Table Of Contents

1. INTRODUCTION.....	4
1.1 PURPOSE	4
1.2 SCOPE	4
1.3 ACRONYMS	4
1.4 REFERENCES	5
2. OVERVIEW.....	6
2.1 SUPERATTENUATOR.....	6
2.1.1 <i>Advanced Virgo</i>	7
2.1.2 <i>Present Performances vs Specifications</i>	7
2.2 SUSPENSION CONTROL SYSTEM	8
2.2.1 <i>Top Stage Control</i>	8
2.2.2 <i>Payload Control</i>	9
2.2.3 <i>Motors Control</i>	11
2.2.4 <i>Performances</i>	11
3. SUSPENSION CONTROL HARDWARE.....	12
3.1 FRONT END ELECTRONICS	12
3.1.1 <i>LVDT</i>	12
3.1.2 <i>Accelerometers</i>	13
3.1.3 <i>Coil Driver</i>	14
3.1.4 <i>Motors Driving Electronics</i>	16
3.1.5 <i>Piezoelectric Actuators Drivers</i>	16
3.1.6 <i>Thermal Stabilization Control</i>	17
3.2 DATA CONVERSION, PROCESSING AND TRANSFER	17
3.2.1 <i>Noise Performances</i>	19
3.2.2 <i>Upgrades</i>	21
3.2.3 <i>DSP</i>	21
3.2.4 <i>ADC & DAC</i>	23
3.2.5 <i>Data Path Optimization</i>	26
3.3 OTHER ACTIVITIES	27
3.3.1 <i>Angular Accelerometer Electronics</i>	27
3.3.2 <i>Conduction Cooling</i>	27
3.3.3 <i>DC Supplies Distribution</i>	27



4.	SUPERATTENUATOR CONTROL SOFTWARE.....	28
5.	TASKS	30
5.1	FRONT END ELECTRONICS	30
5.1.1	<i>Crates Replacement</i>	<i>30</i>
5.1.2	<i>Cabling.....</i>	<i>30</i>
5.1.3	<i>LVDT Conditioning Boards.....</i>	<i>30</i>
5.1.4	<i>Accelerometers Electronics.....</i>	<i>31</i>
5.1.5	<i>Coil Drivers.....</i>	<i>31</i>
5.1.6	<i>Piezo Drivers.....</i>	<i>31</i>
5.1.7	<i>Motors Driving Control Board.....</i>	<i>31</i>
5.1.8	<i>Motors Driving Power Modules.....</i>	<i>32</i>
5.1.9	<i>Temperature Stabilization Control.....</i>	<i>32</i>
5.1.10	<i>Optical Levers (Roma-Napoli).....</i>	<i>32</i>
5.2	DATA CONVERSION, PROCESSING AND TRANSFER	32
5.2.1	<i>Analog to Digital Converters</i>	<i>32</i>
5.2.2	<i>Digital to Analog Converters</i>	<i>32</i>
5.2.3	<i>DSP</i>	<i>33</i>
5.2.4	<i>Data Transfer Interface.....</i>	<i>33</i>
5.3	SOFTWARE	33
5.3.1	<i>DSP Server</i>	<i>33</i>
5.3.2	<i>Coordination Software.....</i>	<i>33</i>
5.4	SYSTEM ASSEMBLY & INTEGRATION.....	34
5.4.1	<i>Installation.....</i>	<i>34</i>
5.4.2	<i>Cabling.....</i>	<i>34</i>
5.5	COMMISSIONING.....	34
5.6	MAINTENANCE.....	34
6.	COSTS	36
6.1	HARDWARE PRODUCTION.....	36
6.2	MANPOWER.....	37
6.2.1	<i>External Firms.....</i>	<i>37</i>
6.2.2	<i>Profiles.....</i>	<i>38</i>
6.2.3	<i>Virgo & EGO Labs Participation.....</i>	<i>38</i>



1. INTRODUCTION

1.1 Purpose

Purpose of this document is to collect and summarize all information available concerning the upgrade of the Suspension Control System for Advanced Virgo.

1.2 Scope

This document describes upgrades required by the Suspension Control System during next few years. As it will be clear after reading this document, all foreseen upgrades are not requested from the performances point of view. In fact the system fulfils Advanced Virgo requirements as it is, with only few minor points, still to be verified, and concerning items such as the use of fans to cool down electronics (not disturbing suspensions of course, but injecting vibration noise on optical benches) or if we can tolerate few days a year with worsen sensitivity.

In spite of its title, this document describes upgrades of the Suspension Control System independently from Advanced Virgo. Since performances are already met, all changes can be considered only as a natural replacement of obsolete devices (the Suspension Control Systems is composed by about 500 devices). The system is in use now since more than 10 years and would not guarantee Virgo operation beyond 2009 without described upgrades.

1.3 Acronyms

This document contains several abbreviations and acronyms to refer concisely to an item after it has been introduced. The following list is aimed to help the reader in recalling the extended meaning of each short expression.

ADC	Analog to Digital Converter
CCD	Charge-Coupled Device
CEB	Central Building
DAC	Digital to Analog Converter
DSP	Digital Signal Processor
FE	Front End
LVDT	Linear Variable Differential Transformer
NIM	Nuclear Instrumentation Module
PMC	PCI Mezzanine Card
SA	Super Attenuator



TBC	To Be Confirmed
TBD	To Be Defined
VBeX	Virgo Bus eXpansion
VME	VersaModule Eurocard
VSB	VME Subsystem Bus
WS	Workstation
XMC	Switched Mezzanine Card

1.4 References

This report refers to the following documents containing background or detailed information that can be useful for the reader.

- [RD1] Advanced Virgo Preliminary Design, 28 October 2008, VIR-089A-08
- [RD2] Advanced Virgo Suspensions, R. Passaquieti
- [RD3] Advanced Virgo Preliminary Design, 28 October 2008, VIR-089A-08
- [RD4] A. Gennai, VIR-TRE-PIS-4900-151, "DAC Noise", January 2008
- [RD5] A. Gennai, VIR-072A-08 "DAC Noise Contribution to Virgo Sensitivity", June 2008
- [RD6] A. Gennai, D. Passuello, "Arithmetic Noise in DSP", January 2007, Draft
- [RD7] S. Braccini, Study of marionette correction forces.
- [RD8] S. Braccini, SA Positioning Requirements
- [RD9] M. Errante, Tesi di laurea
- [RD10] G. Scandurra, Relazione finale borsa di studio
- [RD11] A. Gennai, New DSP Software: Project Scope, VIR-TRE-PIS-4900-124, 3/5/2005



2. OVERVIEW

This section provides an overview of superattenuators in the configuration used for Virgo and Virgo+. Please refer to [RD2] for detailed description of changes foreseen for Advanced Virgo.

2.1 Superattenuator

VIRGO Superattenuators (SA), often referred also with ‘Suspensions’ and seldom – referring to the vacuum chamber containing superattenuator – as ‘Towers’, are complex mechanical structures used to insulate optical elements from seismic noise. The structure, described by an 80 vibrational modes model, is controlled by 18 coil-magnet pairs commanded with two distinct Digital Signal Processors (DSP) operating at 10 kHz sampling frequency. The suspension status is observed using 20 local sensors plus 3 global sensors available when the full VIRGO interferometer is locked.

A total number of 9 Super-attenuators are currently installed in the Virgo experiment providing seismic isolation to mirrors and input and detection benches. Each Super-attenuator operates in an Ultra High Vacuum (UHV) chamber. 6 Superattenuator are installed in the Virgo Central Building and the other three are located in the North End, West End and Mode Cleaner building respectively. Each Super-attenuator is identified by a two letters code representing the role of optical element suspended to it. Two classes of suspensions, short and long, are used depending on actual chain length and number of Standard Filters (in the Virgo and Virgo+ configuration),

Long Suspensions

- NE** – North End mirror suspension
- WE** – West End suspension
- NI** – North Input mirror suspension
- WI** – West Input mirror suspension

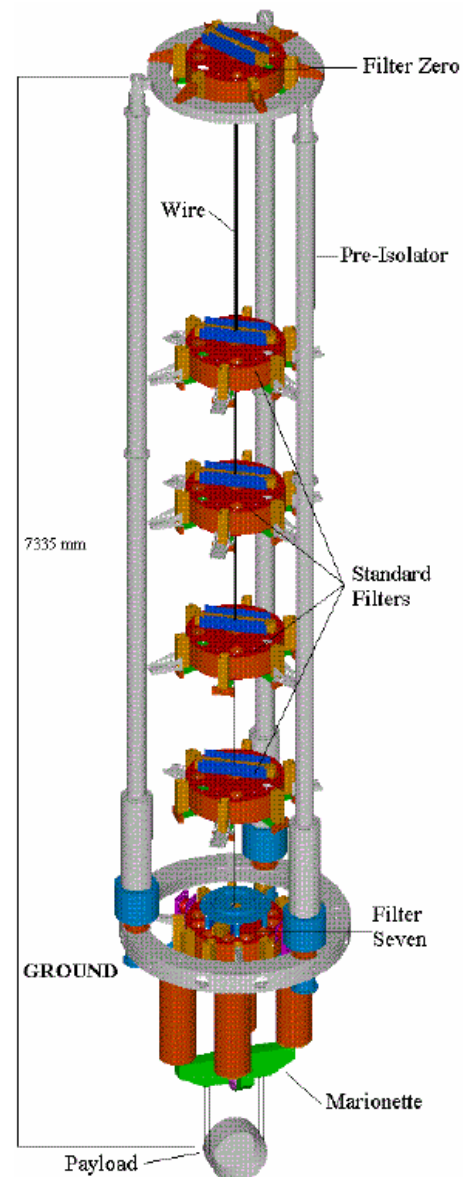



BS – Beam Splitter mirror suspension

PR – Power Recycling mirror suspension

Short Suspensions

IB – Injection Bench suspension

MC – Mode Cleaner mirror suspension

OB – Output Bench suspension

Several actuators are available to set suspension operating point and to control payloads position within required accuracy. 18 coil-magnet pair actuators are distributed in 3 actuation point:

- Filter zero (top stage)
- Filter #7 – Marionette
- Recoil Mass – Mirror

In addition to the magnet-coil pair actuators, 18 stepping motors are distributed along the chain and are used to set the correct operating point.

Several sensors distributed along the Super-attenuator:

- 5 accelerometers (on top stage)
- 14 position sensors (on top stage and distributed along the chain)

Payload coarse local position readout is achieved using a CCD camera while Marionette and mirrors fine local position readout are achieved via optical levers. Feedback control system is digital and implemented using DSP boards designed and manufactured by INFN Pisa.

2.1.1 Advanced Virgo

The main modifications to the Superattenuator are described in details in [RD2] from control point of view they can be summarized in the following main issues:

- Piezoelectric actuators below inverted pendulum legs (3)
- Position sensors detecting piezo actuators displacement
- Angular acceleration sensors located on superattenuator base ring
- Signal Recycling suspension
- Reaction masses (for marionette and mirror) position monitoring (TBC)

Actual installation of angular acceleration sensors depends on outcome of currently running R&D activities.

2.1.2 Present Performances vs Specifications



2.2 Suspension Control System

The Suspension Control System takes care of setting and maintaining the correct operation point for Superattenuators and for suspended optical elements. It is the heart of the Virgo interferometer.

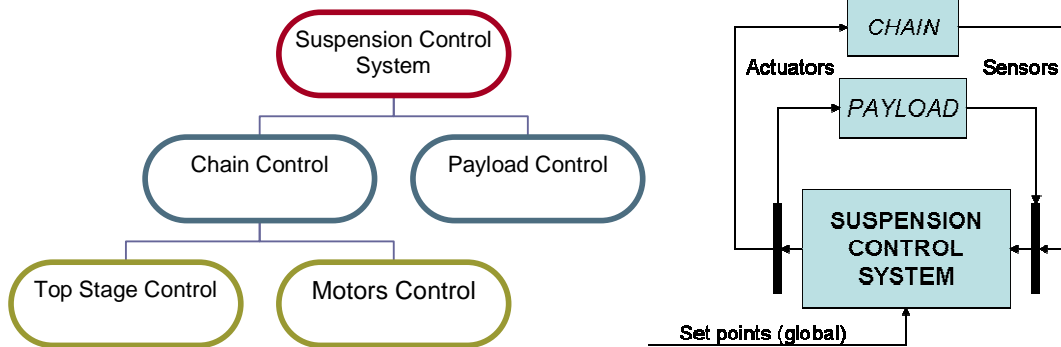

Local controls implement digital feedback control loops using measurements provided by local sensors and include two main multi-variable control loops: Top Stage Control and Payload Local Control.

2.2.1 Top Stage Control

The Top Stage Control (often referred as ‘Inertial Damping’) is the digital control loop in charge of the reduction of suspended payload free motion. During normal operation of the Super-attenuator, the Top Stage Control loop is always active.

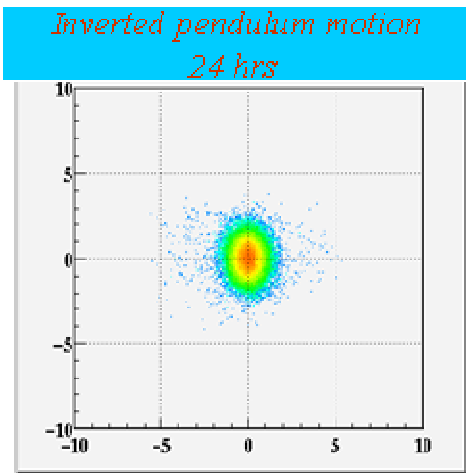

Figure 1 Superattenuator Top Stage



Top stage displacement is continuously monitored using inertial sensors (accelerometers) working in the DC-100 Hz frequency range with an equivalent displacement sensitivity of 10^{-11} m/sqrt(Hz). Together with accelerometers, the actual position in respect with the surrounding supporting structure is monitored using displacement sensors LVDT-like (Linear Variable Differential Transformer) having a displacement sensitivity of 10^{-8} m/sqrt(Hz) and a linear range of ± 2 cm.

The digital control loop operates with a 10 kHz sampling frequency and a loop unity gain frequency of about 5 Hz. Three degrees of freedom are currently controlled (two translation in the horizontal



plane and the rotation along the vertical axis) and a fourth one (vertical translation) is active in some Super-attenuator. The diagonal dominance in the Multiple Input Multiple Output (MIMO) system is achieved using static (constant) sensing and driving matrices. Today performances allow a residual displacement less than 1 μ m at the level of suspended payload and a relative speed between long arm cavities input and end mirrors of about 0.25 μ m/sec. As already discussed in paragraph 2.1.2, these performances meet Advanced Virgo requirements.

2.2.2 Payload Control

The Payload Control is the digital control loop in charge of the positioning of suspended payload. Additional functionality is the damping of unwanted mirror motion. We can distinguish among two different operational modes. When the interferometer is unlocked, payload control makes use of measurements made in respect with a local reference frame. When the Virgo interferometer is in locked state, payload control makes use of set points distributed by global

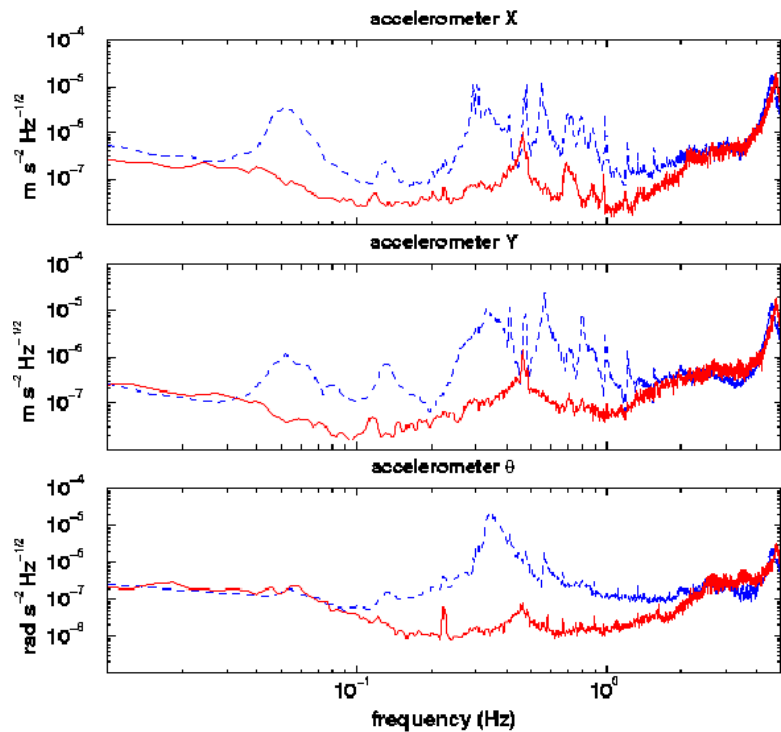



control and alignment computer. Mirrors position is corrected along three degrees of freedom: longitudinal displacement (along the Virgo laser beam direction – ‘Z’), rotation around the vertical axis (‘ThetaY’) and rotation along the horizontal axis orthogonal to laser beam direction (‘ThetaX’). Correction of longitudinal position is named in Virgo ‘Locking’ while correction of ThetaX and

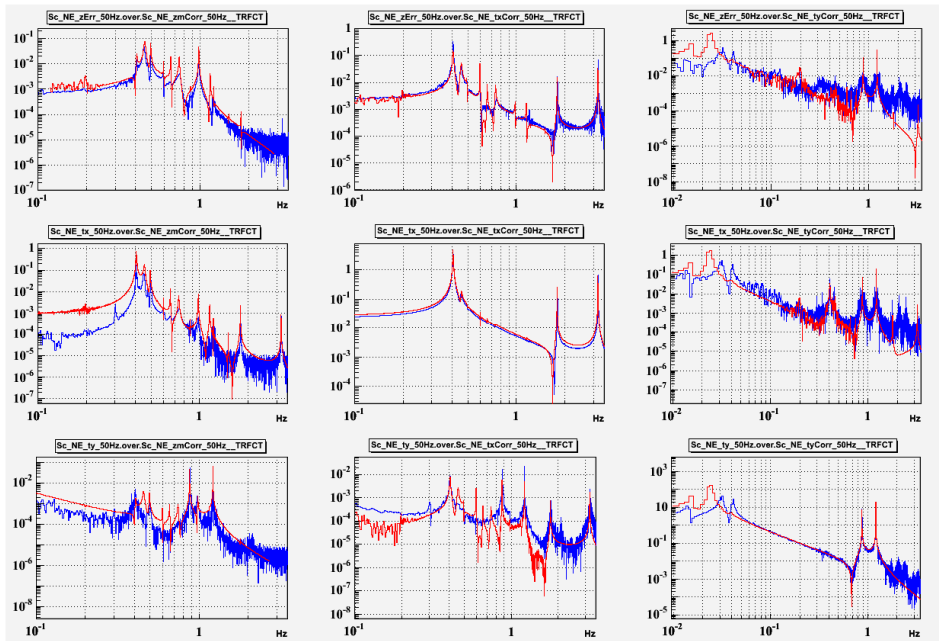

ThetaY angles is named ‘Automatic Alignment’. The low frequency part (10s of mHz) of the Z error signal is forwarded to Superattenuator Top Stage Control for correcting tidal strain acting on top stage where we can achieve bigger

displacements. Local payload position is monitored using two Position Sensing Devices reading Marionette and Mirror positions respectively plus a CCD camera reading the mirror coarse position as shown in the following picture. Performances of payload control system meet Advanced Virgo requirements allowing a residual angular displacement less than 1 urad using local sensors and less than 1 nrad using angular displacement measurements outputs from Virgo ITF.

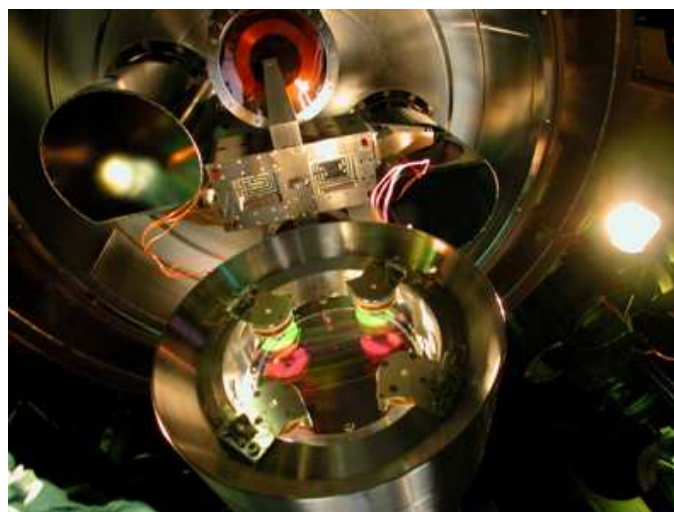

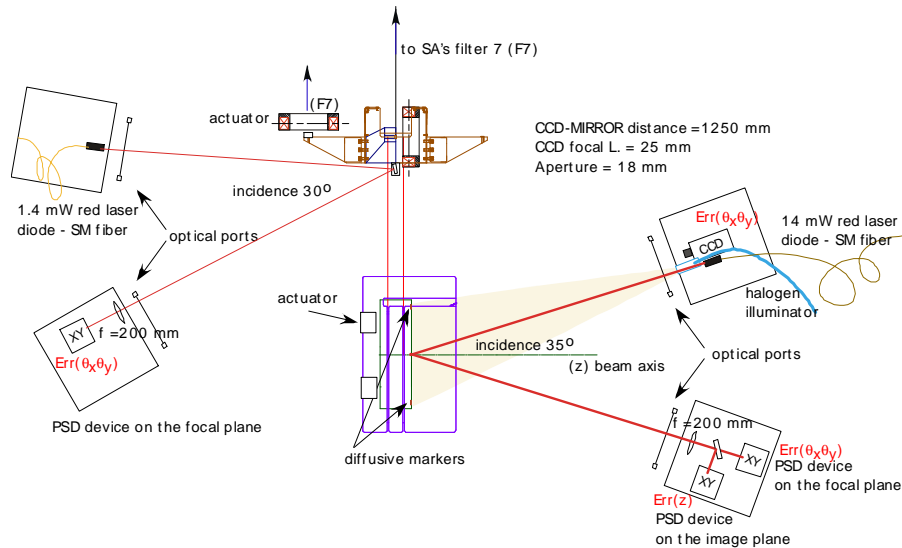

Figure 2 Payload Local Control: position readout

2.2.3 Motors Control

Along the Super-attenuator chain there are several stepping motors used to set the correct operating state. This paragraph list main motors only to give a rough idea of their use.

Each accelerometer has a motor for cancelling dc output by moving accelerometers suspended mass. Three motors acting on top stage are used for setting the Super-attenuator dc position. One motor acts on the so called 'Chiocciolone' for setting the vertical length of the whole chain. One motor ('Fishing Rod' motor) is installed in each of the Standard Filters (see picture at the beginning of this chapter) for setting the anti-spring magnets bar position. Two motors allow rotation of Filter Seven in respect with last Standard Filter and rotation of Marionette in respect with Filter Seven. One motor is installed on Marionette moving a balancing mass and two motors are used to set Filter #7 angles. Requirements for the positioning system are reported in [RD8]

2.2.4 Performances

Overall system performances are excellent and completely fulfilling Virgo and Virgo+ requirements. Only in case of extremely bad weather condition (a few days per year) excess seismic noise could potentially affect Advanced Virgo sensitivity at very low frequency (below 10 Hz) ([RD2][RD7]).



3. SUSPENSION CONTROL HARDWARE

This chapter starts from a description of the Virgo configuration for then moving to changes implemented for Virgo+ and finally describing a proposed Advanced Virgo configuration.

Superattenuator control hardware can be split in three different main categories: Front End Electronics and Data Conversion, Processing and Transfer Electronics and Supervisory Control Workstations

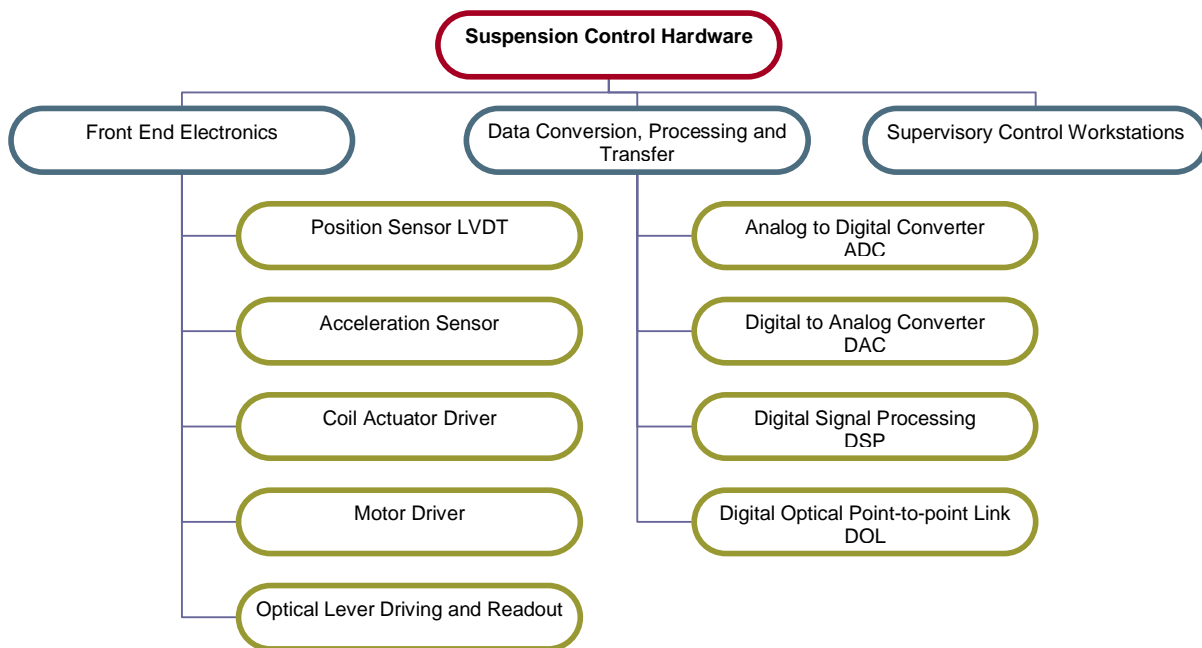

3.1 Front End Electronics

The main activity concerning front-end electronics is the upgrade of the conditioning electronics used to manage the sensor and the actuators placed in the suspension stage, namely the accelerometers, the LVDTs, the stepping motors, the local control sensors and the coil working at different levels of the chain.

3.1.1 LVDT

The LVDT sensors (Linear Variable Differential Transformer, inductive position sensor) actually used to measure the position of the top stage of the suspended chain in the very low frequency band, did not require any particular improvement. They are, in fact (and being dominated by seismic noise), enough sensitive to be compliant with the Advanced Virgo requirements.

On the other hand the conditioning electronics of these sensors need to be upgraded for two main reasons. The first one is the age of the electronic components used in the driver, that are now



obsolete and difficult to maintain; of course and even if not strictly required, using more recent and specific components will produce benefits also in terms of performances. The second reason concerns the possibility to implement a digital output on the driver by using an onboard ADC to immediately digitize the position signal, and sending it to the processing and control electronics through a digital link. This solution has the clear advantage to greatly reduce interferences and electrical pick-ups from the electromagnetic noise present in the environment.

Finally it is foreseen to use such new drivers also to manage the LVDT sensors used inside the accelerometers of the top stage; this solution will avoid the development of hybrid electronic board and will make more logical and easy to maintain the full suspension electronics.

Running Activities

INFN Pisa is being studying a new design for LVDT electronics since a few years. A candidate ADC converter was selected and tested together with a DAC converter and a PLL circuitry capable of letting the two converters operate at different rates synchronously with VIRGO timing signal.

Such studies were partially integrated in the R&D activity for the upgrade of Virgo control electronics together with new DSP design. Characterization of the developed prototype board was subject of a University Degree thesis by M. Errante, “Caratterizzazione e realizzazione di una scheda di conversione D/A A/D per l’esperimento VIRGO “, Facolta’ di Ingegneria Univerita’ di Pisa ([RD9]).

Digital data link was studied taking advantage from a fellowship (Dr. G. Scandurra) paid by Fondazione Bonino-Pulejo. The final report was “Sviluppo di una scheda di I/O dotata di interfacce PCI e IEEE1394b per il rivelatore Virgo” ([RD10])

3.1.2 Accelerometers

The main upgrade foreseen for the driving electronics is the replacement of a digital feedback instead of the analog one currently used in addition to the use of an external LVDT driver and the introduction of a digital output for the acceleration signal, as already stated in the previous section,.

The upgrade of the accelerometers used to perform the inertial damping of the top stage involves both the sensor and the internal driver (sensors are force-balance accelerometers). At sensor level some adjustment in the design is needed to enhance the performances. In particular the balancing and the stability of the suspended mass, have to be improved for enhancing noise performances, especially in the low frequency range, that is the most interesting for the inertial damping application.



The implementation of such digital system would allow the design of more effective feedback for the internal loop, resulting in a wider frequency band, in an improved robustness and in improved noise performances.

Of course for this aim some suitable additional electronics has to be hosted on the driver, namely an ADC to digitize the position signal coming from the LVDT, a DSP for the digital filtering, and a DAC for the actuation on the internal coil.

Running Activities

In addition to the studies carried on for ADC and DAC converter mentioned in the previous section, a few different options for the digital controller implementation were investigated by INFN Pisa. Such controller could be implemented with either a devoted DSP processor or with one of the multi-DSP boards developed by INFN Pisa handling several sensors at a time or with fast FPGA.

Concerning the actuation, a few initial studies were carried on to evaluate the possibility to replace existing voice coil actuator (coil-magnet) with a coil-coil pair.

3.1.3 Coil Driver

The Coil Driver were upgraded for Virgo+ and their current performances, in terms of noise, linearity and frequency band are already compliant with the Advanced Virgo requirements [RD5].

The major upgrade is related to the introduction of a digital input, through a fast optical link connected to an onboard DAC and to a selection of a new DAC converter (the one in use is obsolete). The digital link is particularly important since the actuation signals of the coil are the most critical for the ITF sensitivity, and a connection between the control and processing electronics that is virtually unaffected by environmental interferences is strongly desirable.

New Coil Drivers ACDV-07-P2 are Eurocard 6U boards each one hosting two independent channels.

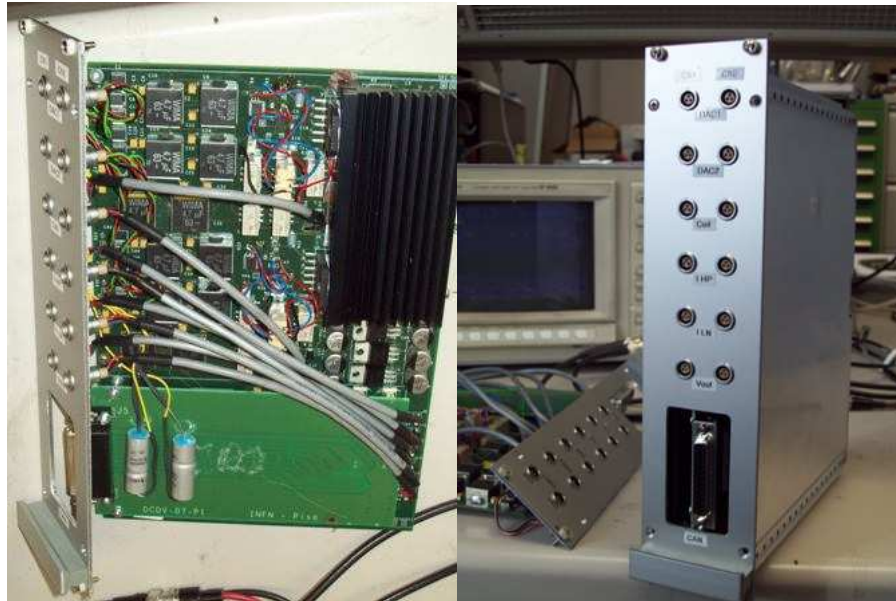

Figure 3 New coil driver evaluation board

Each channel has two inputs, DAC#1 and DAC#2, one main output COIL and three monitoring outputs: Voltage Monitor (VMONI), High Power Mode Current Monitor (HPMONI) and Low Noise Mode Current Monitor (LNMONI). One parallel digital input allows remote control of board operating mode.

Detailed information about the Coil Driver theory of operation and main specifications can be found in Virgo+ review documentation available at:

<http://wwcascina.virgo.infn.it/collmeetings/DMwebpages/Virgo+/2ndReviewDocuments/coildrivers.pdf>

Coil Drivers are power amplifiers used to drive coil-magnet pair actuators steering VIRGO optical elements. Those amplifiers need a wide dynamical range due to the big force impulse required to acquire the lock of VIRGO optical cavities and stringent noise behavior during linear regime.

The new coil driver was designed using two distinct sections: one high power section for lock acquisition and one low noise section for linear regime. The two sections are driven by two independent digital to analog converter channels. The new coil driver can supply up to 2 A during the lock acquisition phase with a few nA/Hz^{1/2} of noise during linear regime.

The ACDV-P2 version of the new coil driver hosts three distinct sections. The following picture shows a functional block diagram for one Coil Driver channel. For each magnet-coil actuator pair, two analog inputs are available. Due to the high dynamics of the current flowing into the coil, also the monitoring section is split in two parts: Coarse (High Power) and Fine (Low Noise).

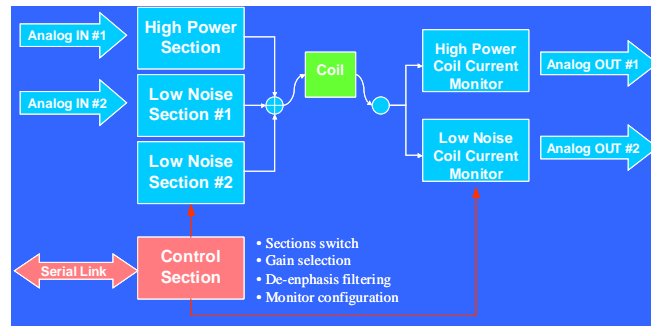

Figure 4 New coil driver block diagram

For each actuator three distinct section are available (one High Power plus two Low Noise). The High Power section is a transconductive amplifier able to supply up to 2 A into the coil while the two Low Noise sections are voltage amplifiers with resistor in series with the coil.

Running Activities

R&D related to the development of an engineered version of coil driver prototypes is now closed. What still remains to be studied is the use of high power – low noise modes with marionette actuators. Tests will take place during next commissioning phase.

3.1.4 Motors Driving Electronics

No changes are foreseen for the driving system of the stepper motors working on the suspension. A minor change is related to the control logic that is currently obsolete. A standard commercial solution seems the best choice since there are no special requirements on the performances of the system.

Running Activities

Possible solutions are being investigated by EGO Electronics group in collaboration with INFN Pisa.

3.1.5 Piezoelectric Actuators Drivers

Advanced Virgo suspension configuration foresees the use of piezoelectric actuators placed under the inverted pendulum legs. To drive such actuators we need high voltage amplifiers.

Running Activities

A prototype driver was designed few years ago to drive high voltage (up to 800V) piezos. Design doesn't allow driving negative polarization piezos (the most common ones). Recently a new design was developed to drive piezo actuators up to +/- 150V. Investigation with Physik Instrumente (PI) is in progress to have piezo being able to cover our travel range with such mid voltage. Using 150V



instead of 800V would enormously simplify signals cabling, vacuum feed-through and of course operation. A few boards were developed founded outside the Virgo project.

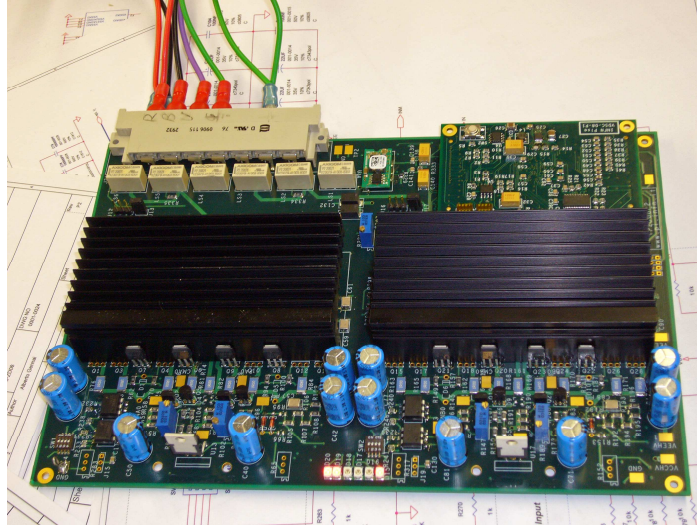

Figure 5 Dual Channel +/- 150V Piezo Driver Board

3.1.6 Thermal Stabilization Control

Since several years a thermal stabilization system, required to control the temperature of the suspension and therefore its length and filters operating points, is ready to be installed. For proper operation of the suspension enclosure temperature variations shall not exceed +/- 0.2 °C. This requirement was up to now fulfilled stabilizing the temperature of the whole central hall and terminal building. Since such requirement could be easily met using heating belts wounded around towers, we could relax specifications on air conditioning system allowing temperature variations into the building up to 2 °C. It is also worth mentioning that very low frequency variation of the air temperature do not affect at all suspension performances. We could therefore allow a continuous change of mean temperature following seasons change.

3.2 Data Conversion, Processing and Transfer

Each of the 9 Virgo Superattenuators has a dedicated Suspension Control Unit composed by one VME crate hosting data conversion, processing and communication boards. A Suspension Control Unit hosts two PowerPC-based CPU boards, running real time operating system LynxOS, used for supervision and for CCD camera readout software. Hard real-time signal processing is performed using two Digital Signal Processing (DSP) boards based on Motorola DSP96002 floating-point DSP. Control Unit is completed by about 60 channels of analog I/O, 4 digital optical point-to-point links, CCD camera and Timing system interface. Suspension Control Units are located in the Virgo



Data Acquisition Room and in the two Terminal Building. A second crate hosting front-end analog electronics is located close to each suspension tower.

DSPs implement the hard real-time part of the control system. The following table summarizes measured load.

DSP	Program Memory (kBytes)	Data Memory (kBytes)	MFLOPS (Average)	MFLOPS (Sust.)	I/O (M bit/sec)	% Used
<i>BC</i>	6.6	1.3	7	13	16.0	55%
<i>BS Down</i>	9.3	1.6	10	14	18.9	77%
<i>BS Up</i>	7.6	1.9	11	17	15.7	63%
<i>IB Down</i>	8.8	1.6	10	14	12.8	73%
<i>IB Up</i>	7.0	1.7	9	16	14.4	59%
<i>MC Down</i>	9.3	1.9	12	16	17.0	78%
<i>MC Up</i>	6.9	1.9	10	18	13.4	57%
<i>NE Down</i>	9.5	1.8	11	14	19.5	79%
<i>NE Up</i>	7.6	1.9	11	17	16.0	64%
<i>NI Up</i>	7.6	2.0	11	17	15.7	64%
<i>NI Down</i>	8.7	1.7	11	15	17.6	73%
<i>OB Down</i>	5.7	1.1	8	16	17.0	47%
<i>OB Up</i>	6.8	1.8	9	17	13.4	57%
<i>PR Up</i>	7.4	1.9	10	17	15.4	62%
<i>PR Down</i>	8.3	1.7	11	15	15.4	70%
<i>WE Up</i>	8.8	2.1	12	16	21.8	73%
<i>WE Down</i>	9.4	1.8	11	15	18.9	78%
<i>WI Down</i>	8.8	1.7	11	15	17.6	73%
<i>WI Up</i>	7.7	2.0	11	17	15.7	64%

Figure 6 DSP Load

The distributed load adds up to about 300 MFLOPS, 300 Mbit/sec I/O rate with a latency lower than 100 usec. The system was designed in the mid 90's and it is operative 24 hours a day 365 days per year since 1998.

Within a Suspension Control Unit, three are the communication standards used to access interface devices: VME (VersaModule Eurocard), VSB (VME Subsystem bus) and VBeX (Virgo Bus eXpansion). VMEbus is used for communication involving one of the two CPUs and average throughput is in the order of 40 kBytes/sec. VSB bus is used for communication between DSP and Digital Optical Link interfaces to receive data from Global Control and to send data to Data Acquisition with 800 kBytes/sec total throughput. VBeX shares the physical layer with the VSB bus but uses an asynchronous private protocol. This bus is used for communication between DSP and



analog to digital (ADC) and digital to analog (DAC) conversion board (1 MByte/sec total throughput).

DAC boards, designed together with ADC and DSP boards by INFN Pisa, are 8 channels, 20 nominal bits (17.5 effective bits) operating in Virgo at the sampling rate of 10 kSample/sec. Analog anti-aliasing (reconstruction) filter is a 7th order Cauer filter with 3.7 kHz cut-off frequency. Balanced outputs provide a 20 Volts peak-to-peak signal.

ADC boards are 8 differential channels, 16 nominal bits (14.5 effective bits) operating in Virgo at the sampling rate of 10 kSample/sec. Analog anti-aliasing filters is the same used in DAC boards: 7th order Cauer filter with 3.7 kHz cut-off frequency. Dynamical range of differential inputs is 20 Volts peak-to-peak.

DSP boards, operate at the sustained rate of about 10 million floating point operation per second (MFLOPS) for a total computational power in the range of 200 MFLOPS for controlling 9 Superattenuators. Computational power is used to implement control filters with about 100 poles per DSP board within an interrupt service routine activated with a repetition period of 100 microseconds and triggered by Virgo timing distribution system. Within such period DSP reads input from ADC boards and communication links, computes correction signal and sends results to DAC boards and communication links.

Data transfer take place using two distinct mechanisms. Slow monitoring signals (1 second sampling period) are transferred using Ethernet connection available at PowerPC level. Real time signals (10 kHz sampling rate) are transferred using a point to point optical link connecting each DSP to a Data Acquisition Frame Builder. The same mechanism is used by Global Control computer to provide DSPs with proper set points.

3.2.1 Noise Performances

Noise performances of data converters and signal processing were described and analyzed in several notes (see [RD4][RD5][RD6]). Since one of the point most frequently misunderstood within the collaboration was the actuation noise (dominated by digital to analog converter noise), it is worth reporting also in this document the converter noise budget for the actuators located on the lower stages of the suspension: marionette and reference mass. The following two plots show the noise budget. The brown line is the expected Advanced Virgo sensitivity at low frequency. The green line is the DAC noise contribution while the blue line can be considered as a safety margin (10 at 10 Hz). Both plots were calculated assuming to drive only the minimum number of actuators (noise decrease with the square root of the number of actuators, therefore noise contribution could



be scaled down by a factor $2\sqrt{2}$) and assuming that, in spite of the large gain in sensitivity (2 orders of magnitude), photodiode signals will not change at all. Finally, DAC noise is based on measurement on devices currently in use but obsolete since a few years and therefore not available in Advanced Virgo.

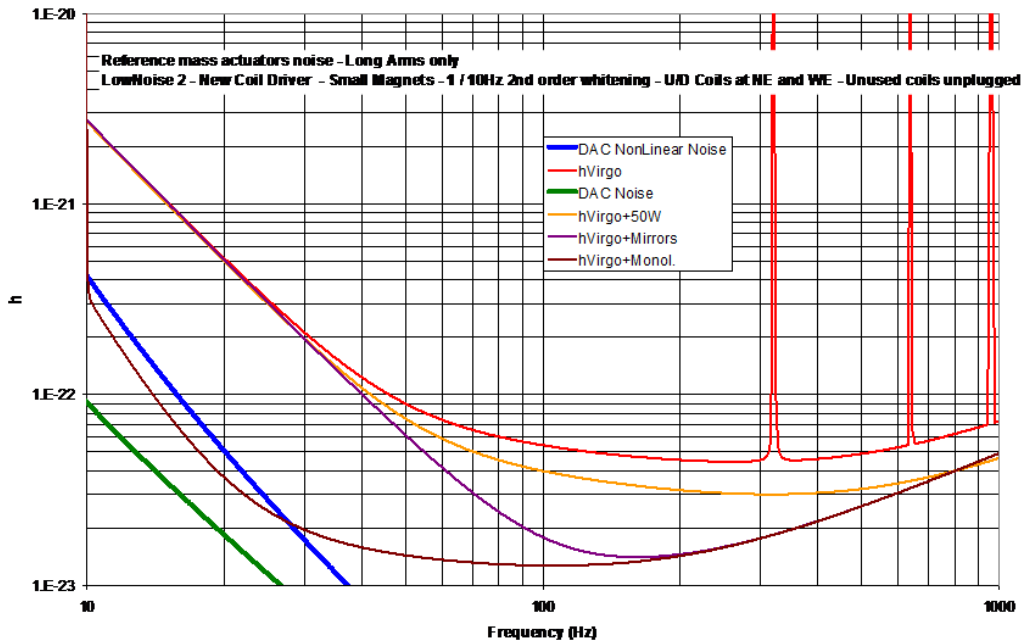

Figure 7 DAC Noise compared to Adv Virgo sensitivity (ref. mass actuators)

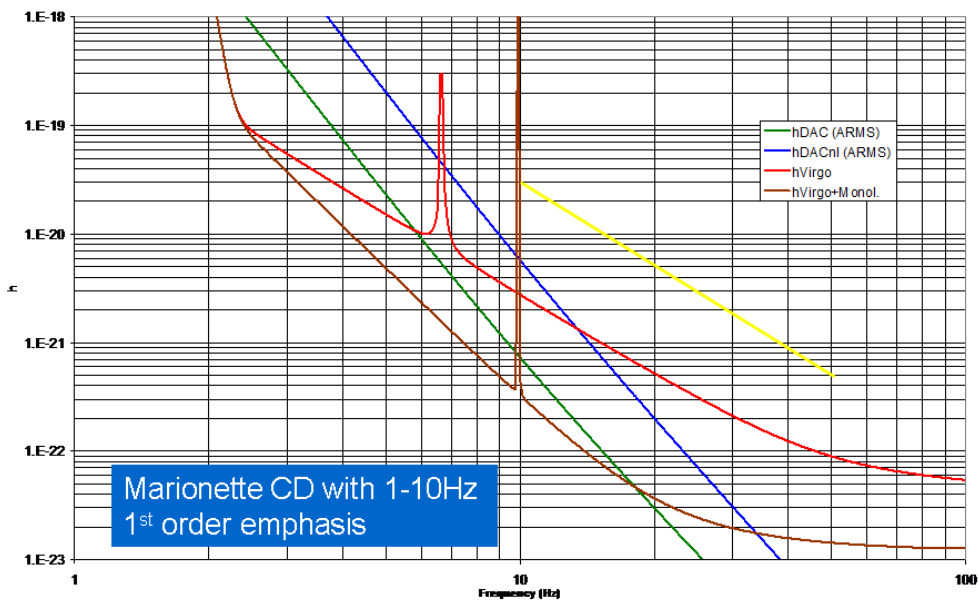

Figure 8 Noise compared to Adv Virgo sensitivity (marionette actuators)



3.2.2 Upgrades

The major upgrade in the architecture of the Processing and Control Electronics, namely the DSP, the ADC, the DAC and the digital optical link, was already performed during the Virgo+ upgrade. In particular the new processing board [see Virgo+ 2nd review document at <http://wwwcascina.virgo.infn.it/collmeetings/DMwebpages/Virgo+/2ndReviewDocuments/DSP.pdf>], with its 6 DSP, allows a very high computing power respect to the old Virgo single DSP board. Moreover the new Photodiode Readout Scheme (section DAQ:PhReadOut) and the new Global Control Architecture (section DAQ:GlobalControl), both based on more recent CPUs and faster digital optical links, allow a better conditioning and an higher frequency band of the error signals. Thanks to these changes it is possible to perform better control strategies and to design more effective digital filters.

Some improvement is still required for the analog/digital converters, ADCs and DACs, in particular about the effective number of bits, in order to reduce the quantization noise introduced during both the sensing and the driving.

3.2.3 DSP

The new DSP board named is being replacing the obsolete DSPV96 board developed by INFN Pisa for VIRGO. The new device is a VME board hosting up to 6 Analog Devices DSPs.

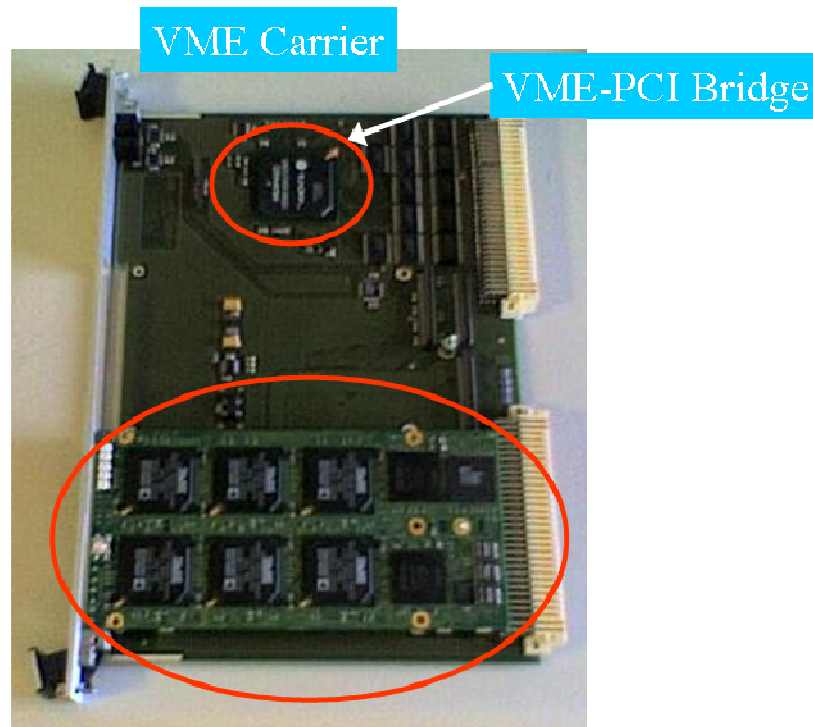

Figure 9 New DSP mezzanine plugged on VME carrier

The board is constituted by a VME carrier board hosting one mezzanine board hosting DSPs and one additional mezzanine board for Timing and fast data links.

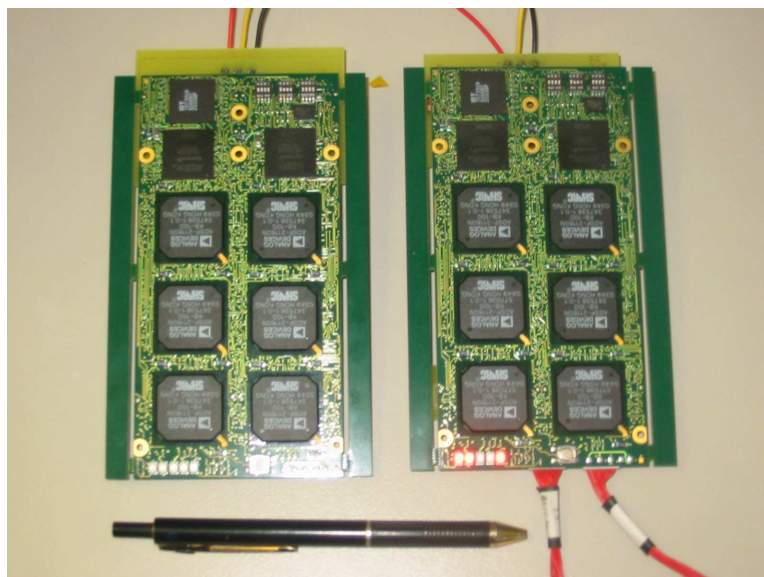

Figure 10 New DSP Mezzanine Board

Detailed information about the new DSP board and main specifications can be found in Virgo+ review documentation available at:

<http://wwwcascina.virgo.infn.it/collmeetings/DMwebpages/Virgo+/2ndReviewDocuments/DSP.pdf>



No major change is foreseen on the processing board. Nevertheless a daughter-board has to be developed to manage the digital signals exchanged with the suspension electronics equipped with digital input or output. The architecture should be very similar to the one already implemented for the global control signal in Virgo and in Virgo+, but in this case it refers also to local control signals.

Running Activities

Digital data link was studied by INFN Pisa taking advantage from a fellowship (Dr. G. Scandurra) paid by Fonzaione Bonino-Pulejo. The final report was “Sviluppo di una scheda di I/O dotata di interfacce PCI e IEEE1394b per il rivelatore Virgo” A preliminary design of the board is already available.

3.2.4 ADC & DAC

The ADC of the control electronics, in the Virgo and Virgo+ configuration, are located in the same unit of the processing electronics and are used mainly to convert signals coming from the suspension electronics, located close to the respective tower. In Advanced Virgo some of these converters will be placed directly in the suspension electronics (section DAQ:SuspEle). Despite of their location, an improvement of their performances, mainly in terms of quantization noise reduction, should be achieved.

As for the case of ADC, also the DAC performances need to be improved. The DAC noise is even more critical, since the current performances are still a limiting factor for the achievement of the Advance Virgo sensitivity in the low frequency region, due to the direct coupling with the coils actuating on the test masses. A specific R&D is dedicated to the selection of a suitable chip, with an higher number of bits respect to now and higher sampling frequency to decrease the noise content.

Running Activities

A candidate ADC converter was selected and tested together with a DAC converter and a PLL circuitry capable of letting the two converters operate at different rates synchronously with VIRGO timing signal.

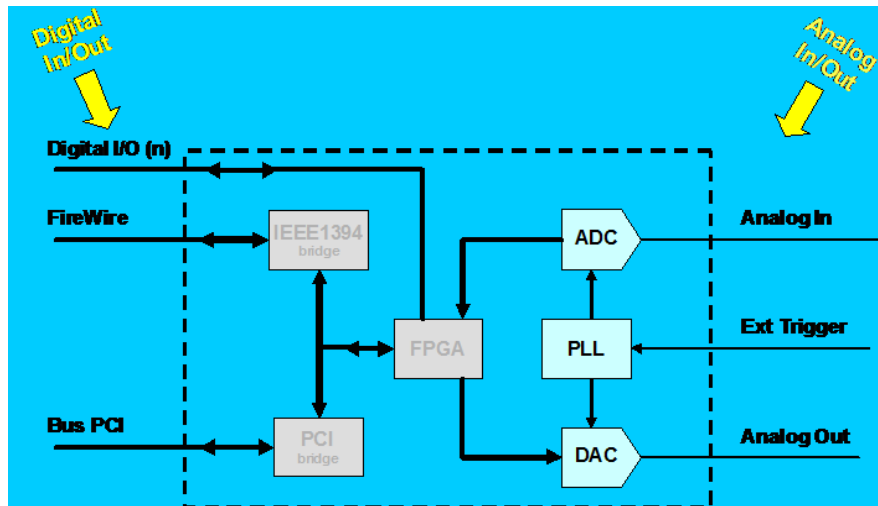

Figure 11 New ADC/DAC board - simplified diagram

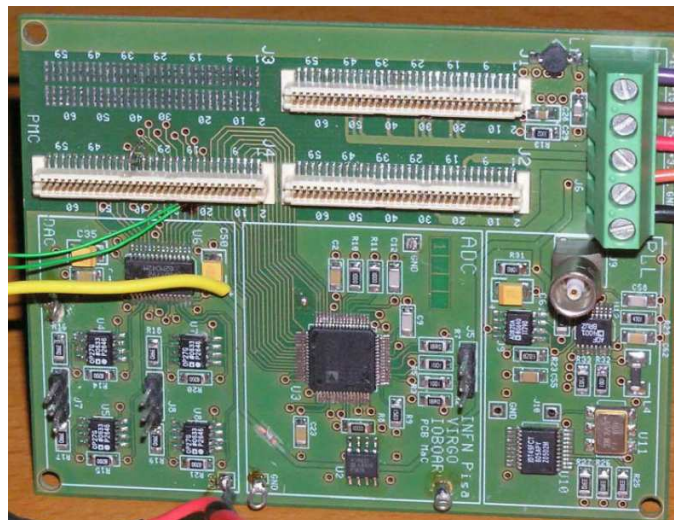

Figure 12 New DAC/ADC evaluation board

Such studies were partially integrated in the R&D activity for the upgrade of Virgo control electronics together with new DSP design. Characterization of the developed prototype board was subject of a University Degree thesis by M. Errante, “Caratterizzazione e realizzazione di una scheda di conversione D/A A/D per l’esperienza VIRGO “, Facolta’ di Ingegneria Univerita’ di Pisa. Obtained results show an noise level about 2 time smaller than the DAC currently in use by Virgo at frequencies larger than a few Hertz. The following table summarize main specifications for the converter in use and for the tested one

AD1862 (in use now)

- 20 bit converter

DSD1792

- 24 bit converter



- 120 dB SNR
- -88 dB THD
- Noise Spectra (20 Vpp output)

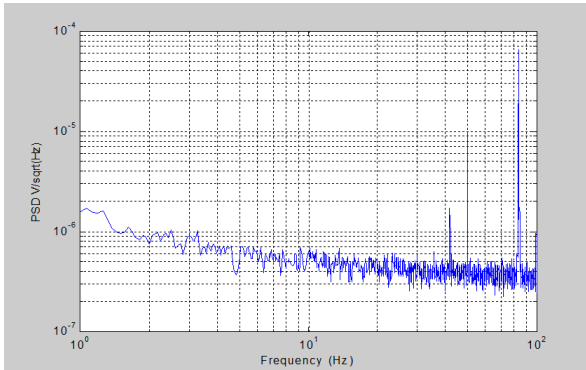

- 125 dB SNR
- -90 dB THD
- Noise Spectra (20 Vpp output)

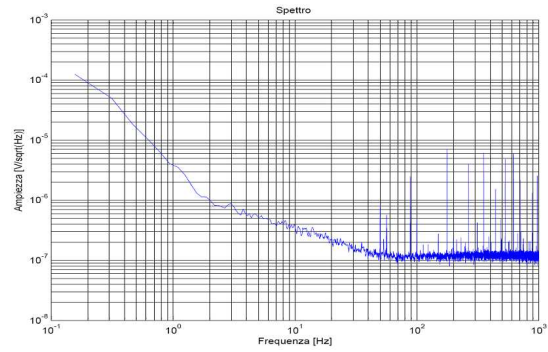



3.2.5 Data Path Optimization

The following picture shows the Virgo / Virgo+ block diagram of the Suspension Control System

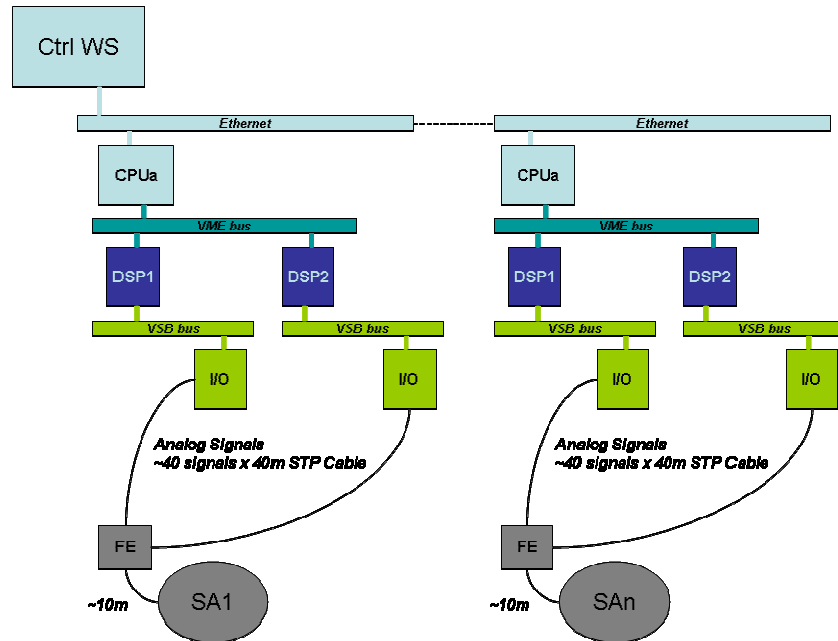

Figure 13 Virgo / Virgo+ Suspension Control System Layout

Architecture proposed for Adv. Virgo is much simplified. VME CPU (RIO) disappears together with more than 1600 m of analog cabling per tower. In the Central Building (CEB) a single fiber could be used to connect all DSPs with control workstation. Such simplification is major step in system reliability and performances due to the huge gain for EMC.

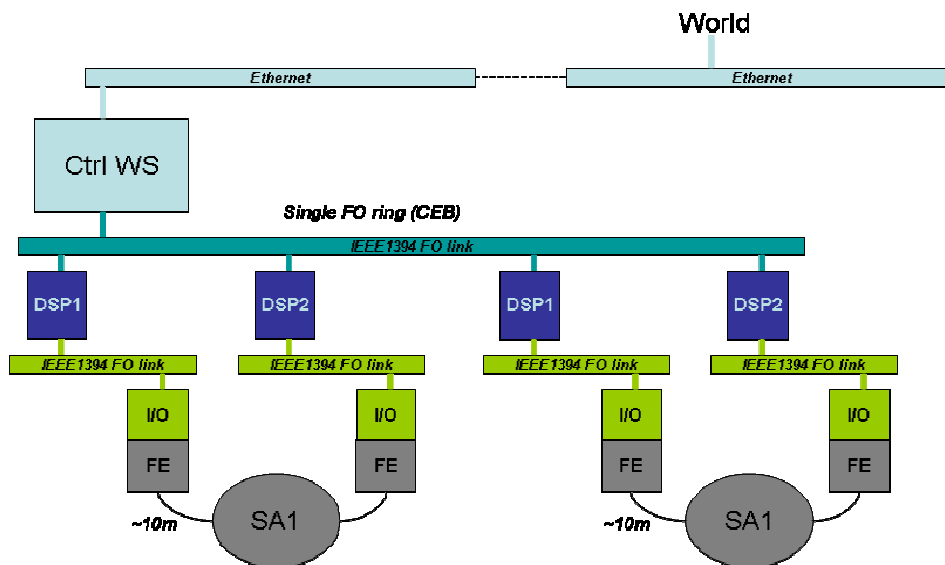

Figure 14 Adv Virgo Layout



3.3 Other Activities

3.3.1 Angular Accelerometer Electronics

Up to today it looks reasonable being able to use the same electronics used for horizontal and vertical accelerometers. All test in progress on the two angular accelerometer prototype available were performed using standard Virgo electronics.

3.3.2 Conduction Cooling

To reduce vibration in the central hall and terminal buildings, the possibility to remove fan from front end racks is under investigation. Adoption of standard IEEE 1101.2 “Standard for Mechanical Core Specifications for Conduction-Cooled Eurocards” looks to be mandatory to remove fan. Costs for this operation are available but actual benefits are still to be clarified.

3.3.3 DC Supplies Distribution

Removal of power supplies from the experimental area would produce several benefits:

- EMC improvements (mainly on mains 50Hz and harmonics)
- Heat reduction
- Power Supply fans vibrations

Some preliminary investigations are in progress but a cost benefit analysis is not yet available.



4. SUPERATTENUATOR CONTROL SOFTWARE

Since a couple of yeas a redesign of suspension control software is in progress with support from EGO Software group. A quite large amount of documentation is available at <https://workarea.ego-gw.it/ego2/ego/itf/software/auth-only/projects/superattenuator-control-software> (EGO-Virgo Workarea, access require a workarea login and passwd). The following pictures show architecture and layout of suspension control software for Adv.Virgo

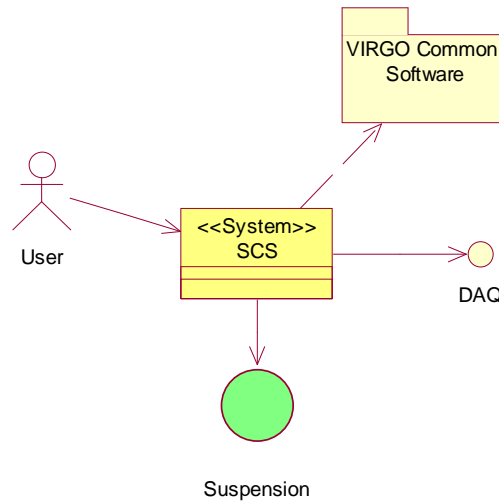

Figure 15 Top level context diagram

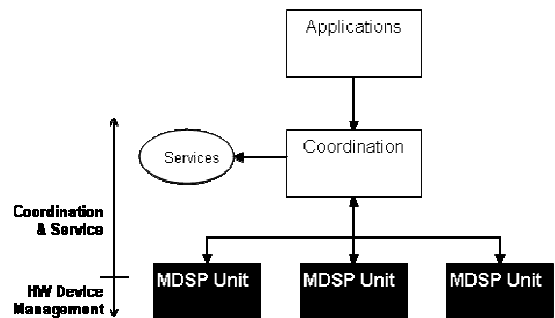
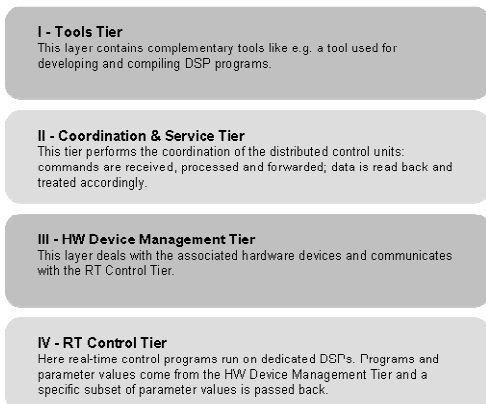

Figure 17 Software Layout

Figure 16 Software Architecture

Super-attenuator Control Software (SCS) shall allow maintenance, configuration and operation of the whole set of Suspensions.



- The main purposes of the first SCS version can be summarized as follows:
- Handle replacement of DSP currently in use conserving existing functionalities.
- Provide in-system test capabilities for hardware devices.
- Minimize changes on interfaces with external packages.
- Simplify operations
- Provide online help
- Improve portability towards environments different from the Virgo one.
- Improve software fault tolerance and maintainability



5. TASKS

This chapter summarizes the main tasks related to the upgrade of Suspension Control System for Advanced Virgo. For each task a few lines recall main motivations and describe implementation. Three attribute were added: Need (Desirable, Very Desirable, and Mandatory), Priority (Low, Mean, and High) and Risk (Low, Mean, and High). A preliminary estimation of costs is available in next section.

5.1 Front End Electronics

5.1.1 Crates Replacement

Motivation: Standard in use (NIM) will be abandoned since is no longer available, adoption of standard IEEE 1101.2 or equivalent (TBC). VME Crate will be abandoned since no longer necessary for communication with other Virgo sub systems.

Implementation: NIM crates will be replaced with Eurocard ones. At present we have 2 NIM crate + 1 VME crate for a total of 3 crates to be replaced for each suspension.

Need: Crate replacement is *Mandatory*. Still TBD the need of conduction cooling

Priority: *High*

Risk: *Low*; Mean if conduction cooling is requested.

5.1.2 Cabling

Motivation: Replacement of crates and electronics.

Implementation: Cabling will be simplified a lot, see related paragraph in this document.

Need: *Very Desirable*.

Priority: *High*

Risk: *Low*.

5.1.3 LVDT Conditioning Boards

Motivation: components obsolete, digital output to improve EMC, adoption of standard IEEE 1101.2 or equivalent (TBC).

Implementation: Eurocard module hosting from 4 to 8 channels.

Note: Same board will be used for accelerometers internal LVDT.

Need: *Mandatory*.

Priority: *High*

Risk: *Mean*.



5.1.4 Accelerometers Electronics

Motivation: components obsolete, digital output to improve EMC, digital control to improve performances, replacement of voice coil actuator with coil-coil pair (TBC¹), adoption of standard IEEE 1101.2 or equivalent (TBC)

Implementation. Eurocard module hosting from 4 to 8 channels.

Need: *Mandatory.*

Priority: *High*

Risk: *Mean.*

5.1.5 Coil Drivers

New coil drivers were designed for Virgo+ and no changes are expected for Adv. Virgo. Nevertheless adoption of standard IEEE 1101.2 or equivalent will imply a redesign of boards. In addition production of coil driver for complete replacement is not part of Virgo+ upgrades that was covering only the lower stage of superattenuators. Virgo+ coil drivers already foresee digital I/O.

Need: *Desirable, Mandatory* if conduction cooling is required

Priority: *Low*

Risk: *Mean.*

5.1.6 Piezo Drivers

Need: *Desirable*

Priority: *Low*

Risk: *Mean.*

5.1.7 Motors Driving Control Board

Motivation: no spare available and not reproducible, move out from VME standard.

Implementation: commercial solution or development of custom control boards (see related paragraph in this document)

Need: *Very Desirable*

Priority: *Low*

Risk: *Mean.*

¹ This possibility already mentioned in the paragraph describing accelerometers electronics would imply re-manufacturing of all accelerometers mechanics. Such mechanical change, whose workload is dominant in respect with electronics, is not detailed in this document.



5.1.8 Motors Driving Power Modules

Modules are still commercially available and we do not foresee a replacement. Crate backplane is custom and shall be probably replaced.

Need: *Very Desirable*

Priority: *Low*

Risk: *Mean.*

5.1.9 Temperature Stabilization Control

Motivation: provide digital I/O for linear power supplies.

Need: *Desirable*

Priority: *Low*

Risk: *Low.*

5.1.10 Optical Levers (Roma-Napoli)

This task is reported only for completeness.

Motivation: Standardize (TBD), allow alignment remote control

Need: *Very Desirable*

Priority: *Mean*

Risk: *High.*

5.2 Data Conversion, Processing and Transfer

5.2.1 Analog to Digital Converters

Motivation: Move out of VME standard and in particular move close to front end electronics, improve noise and bandwidth performances.

Implementation: Mezzanine board, presumably standard PMC, hosting a TBD number of ADC and DAC channels. Mezzanine board will be located directly on front modules.

Need: *Very Desirable*

Priority: *Mean*

Risk: *High.*

5.2.2 Digital to Analog Converters

Motivation: chips obsolete, move out of VME standard and in particular move close to front end electronics, improve performances.

Implementation: See previous paragraph



Need: *Mandatory*

Priority: *High*

Risk: *High.*

5.2.3 DSP

New DSP were designed for Virgo+. Few changes could anyway be required as for example move from PMC to XMC standard (i.e. add one or two connectors). See DSP paragraph in this document for further info.

Need: *Desirable*

Priority: *Low*

Risk: *High.*

5.2.4 Data Transfer Interface

Motivation: see relate paragraph 3.2.5

Implementation: both converter and processing cards will share a fast real-time communication interface based on IEEE1394 standards (and/or USB 3.0 and/or PCI Express all TBD). Such interface, at the today level of the preliminary design, can be seen as a mezzanine board plugged (or integrated) on both DSP and ADC/DAC carrier boards.

Need: *Very Desirable*

Priority: *Mean*

Risk: *High.*

5.3 Software

5.3.1 DSP Server

Motivation: RIOs will no longer be used.

Implementation: see software chapter in this document.

Need: *Very Desirable*

Priority: *Mean*

Risk: *Mean.*

5.3.2 Coordination Software

Motivation: Virgo software supervisor and cm no longer maintained.

Implementation: see software chapter in this document.

Need: *Very Desirable*



Priority: *Mean*

Risk: *Mean.*

5.4 System Assembly & Integration

5.4.1 Installation

(This task was left intentionally empty)

5.4.2 Cabling

(This task was left intentionally empty)

5.5 Commissioning

(This task was left intentionally empty)

5.6 Maintenance

Maintenance has a not negligible cost that will affect budget beyond the installation. For the Suspension Control System maintenance interventions are classified into three different levels:

<i>Level</i>	<i>Applies to</i>	<i>Action Time Scale</i>
1	Sudden Failure (failure = anything preventing continuing Virgo operation at usual sensitivity level)	Hours
2	Request for a change affecting the Suspension Control System but not its interfaces with other Virgo Sub-Systems	Days
3	Request for a change affecting the Suspension Control System and its interfaces with other Virgo sub-systems	Weeks

Table 1 Support Levels

Failure Use Case

Primary Actor: User

Standard Course

- User detects a sudden failure prevent continuing Virgo operation at usual sensitivity level.
- User creates a Problem Report sending an e-mail to spr@ego-gw.it shortly describing problem.
- User contacts Maintenance Staff, if out standard working time using OnCall service, thus activating a Level 1 Support procedure.
- User will receive Problem Report status information and worklog via e-mail.



- Control Room will be keep informed.

Level 1 Support Use Case

Primary Actor: Maintenance Staff (MS)

Standard Course

- Upon receiving notice of a failure, Maintenance Staff (MS) replies to Problem Report email (or create Problem Report entry in case it doesn't exist).
- MS makes a cross check to confirm failure.
- In case of confirmed failure, MS asks Control Room permission to proceed to problem solving (requesting support if needed).
- MS reports any change in the hardware configuration into the Online Database of Electronic Devices and in Virgo logbook.
- After problem fixing, MS reports actions updating the Problem Report entry and informing Control Room
- Problem Report entry is closed.

<i>Action</i>	<i>Software Tool</i>
<i>Problem Report</i>	Software Problem Report (spr@ego-gw.it)
<i>Change Request</i>	Software Problem Report (spr@ego-gw.it)
<i>Hardware Change</i>	Online Database of Electronics Devices & Logbook
<i>Software Change</i>	CVS Archive & Logbook

Table 2 Software Tools



6. COSTS

6.1 Hardware Production

NOTE: Costs do not include in vacuum cabling whose cost was added to the mechanics costs.

A preliminary estimation of costs foreseen for Advanced Virgo can be done on the basis of what was spent for Virgo. Suspension Electronics, excluding maintenance costs, required about 740 kEuro. Present value, assuming a 2% year increase for 8 years, corresponds to about 940 kEuro.

Keeping in mind previous number we can try to make an evaluation of costs task by task.

Concerning electronic hardware development, assuming to have enough manpower available, we can estimate the following costs based on what we paid for Virgo+ upgrades. Note that costs are computed for 15 towers (10 Adv. Virgo suspensions + SAFE + Laboratory + Test Facility + Spare).

	Ch/Susp	Ch/Board	Nr	Nr. Towers	Total	Production Unit Cost	Production Total Cost (k€)
FE Crates Replacement			3	15	45	3.5	157.5
LVDT Conditioning Electronics	20	4	5	15	75	1.5	112.5
Accelerometer Electronics	7	4	2	15	30	1.5	45
Coil Drivers	10	2	3	15	45	2	90
Motors Control	1	1	1	15	15	1	15
Motors Power	1	1	1	15	15	1	15
Piezo Drivers	3	2	1	15	15	2	30
Thermal Stab.	3	4	1	15	15		
Data Converters	45	8	12	15	180	1.5	270
DSP	2	1	1	15	15	2	30
DSP Carrier	2	1	1	15	15	1	15
Cabling							
						Total	780

Table 3 Hardware Costs Estimate (manpower NOT included – blank cell still TBD)

Which costs are included?

- Prototyping (when needed)
- PCB Manufacturing (external firm)
- Components Procurement
- Boards Assembly (external firm)

Which costs are NOT included?

- Manpower (excluding external firms that will take care of PCB manufacturing and boards assembly)
- Laboratory Tools (firmware, JTAG, test, measurements – scopes, analyzers ..- , supply, reworking station ...)
- Conduction Cooling (if confirmed)
- DC supply (if confirmed)



From previous table we can see that we are talking of something less than 500 electronic devices. To set up such large amount of devices we should setup a properly equipped laboratory. Cost for setting up the laboratory, excluding infrastructure cost, can be estimate in the range between 100 and 200 kEuro.

6.2 Manpower

Following table units are month-man. Divide by 12 to get actual FTE number. Empty cells are to be defined.

	Design	PCB Design	Test	Firmware
<i>FE Crates Replacement</i>			1	
<i>LVDT Conditioning Electronics</i>	4	3	1	2
<i>Accelerometer Electronics</i>	4	3	2	2
<i>Coil Drivers</i>	4	3	2	2
<i>Motors Control</i>	3	2	1	3
<i>Motors Power</i>	3		1	
<i>Piezo Drivers</i>	4	3	1	2
<i>Thermal Stab.</i>				
<i>Data Converters</i>	4	3	2	4
<i>DSP</i>	4	3	2	4
<i>DSP Carrier</i>	3	3	1	3
<i>Scientifical & Technical Supervision</i>	36			
<i>Technical Management</i>	36			
<i>Contracts & Procurement</i>	12			
<i>Software D&D</i>	54			
<i>Installation</i>				
<i>Commissioning</i>				
<i>Maintenance</i>				
Total	230			

(month-man)

Table 4 Manpower

6.2.1 External Firms

We can take advantage from the extensive use of external firms. In particular there two task whose load in terms of manpower is very high but with little pay back: Components procurement and Board assembly supervision. Both task could be assigned to one or two external firms that shall take care of buying selected components from resellers, collect printed circuit boards and assembly notes, verify correctness of assembly and store boards waiting for the installation.



6.2.2 Profiles

At present INFN Pisa is the only confirmed participant to the listed tasks. Available manpower adds up to 2-3 FTE and additional position shall be open. In particular we need:

- System/Control Engineer. Overall coordination support
- Hardware Engineer. Design
- Software Engineer. Firmware
- Electronic Technician. Assembly and test.

6.2.3 Virgo & EGO Labs Participation

Participation to tasks described in this document is of course open. Institution and laboratories willing to participate are more than welcome. Responsibility assignment will follow high level assignments for Advance Virgo.

It is worth mentioning that EGO already participates to some of the listed tasks. In particular EGO is involved since a few years in the upgrade of software [RD11] and in some of the tasks related to the Front End Electronics.

oOo