



SAT Control System



Weekly Meeting
January 31st, 2012



Meeting Agenda

- Running activities status report (all)
- Control System Architecture (A.Gennai)
- Development plan (A.Gennai)
- Mode Cleaner activities (A.Gennai)
- AOB

Control System Architecture

- Summary
 - Goals and requirements
 - Conceptual/Preliminary Design

Goals & Requirements

- Virgo/Virgo+ was a success! (from suspensions point of view)
 - Duty cycle extremely high (few hours off in more than 10 years of operation)
 - Virgo sensitivity never limited by our system.
 - Two major updates (coil drivers and DSPs) almost transparent to operation.
- Why are we talking about a new control system?

Goals

- Replace
 - Obsolete and old components
 - Boards have been running for years therefore MTTF is now too short to start a new decade (unless we start replacing all capacitors and chips)
- Reduce
 - Number and type of boards.
 - Analog signal path length.
 - Connections along the signals path.
 - Power.
- Improve
 - Reliability, operability and maintainability.

Requirements

- Not so many changes:
 - Tiltmeters (t.b.c.)
 - Piezos (today confirmed)
 - Filter #7 Control (6 d.o.f.)
 - Marionette Control (4 d.o.f)
 - Higher closed loop bandwidth for signal recycling operation → much shorter delays → much higher sampling rate (100 kHz – t.b.c. very preliminar)
 - Something still pending since a few years related to software (bugs, supervisor, separate dsp code and parameters, better GUI, data processing, ...)

Conceptual Design

● New DSP

- DSP know how is crucial for Virgo: we MUST develop a new DSP every few years
- Connectivity no longer adequate
- TMS320C6678
 - Eight TMS320C66x DSP Core Subsystems
 - 320 GMAC/160 GFLOP @ 1.25GHz
 - Four Lanes of SRIO 2.1 - 5 Gbaud Per Lane Full Duplex
 - Two Lanes PCIe Gen2 - 5 Gbaud Per Lane Full Duplex
 - Ethernet MAC Subsystem - Two SGMII Ports w/ 10/100/1000 Mbps operation
 - 64-Bit DDR3 Interface (DDR3-1600)

Conceptual Design

- Merge front-end electronics with data converters
- Few boards to be developed
 - LVDT Readout
 - Accelerometer Readout
 - Coil Drivers
 - DSP
 - Custom backplanes and power supply
- Motor Control → INFN Trento/Padova
- Piezo Control → Physik Instrumente

Sketching ...

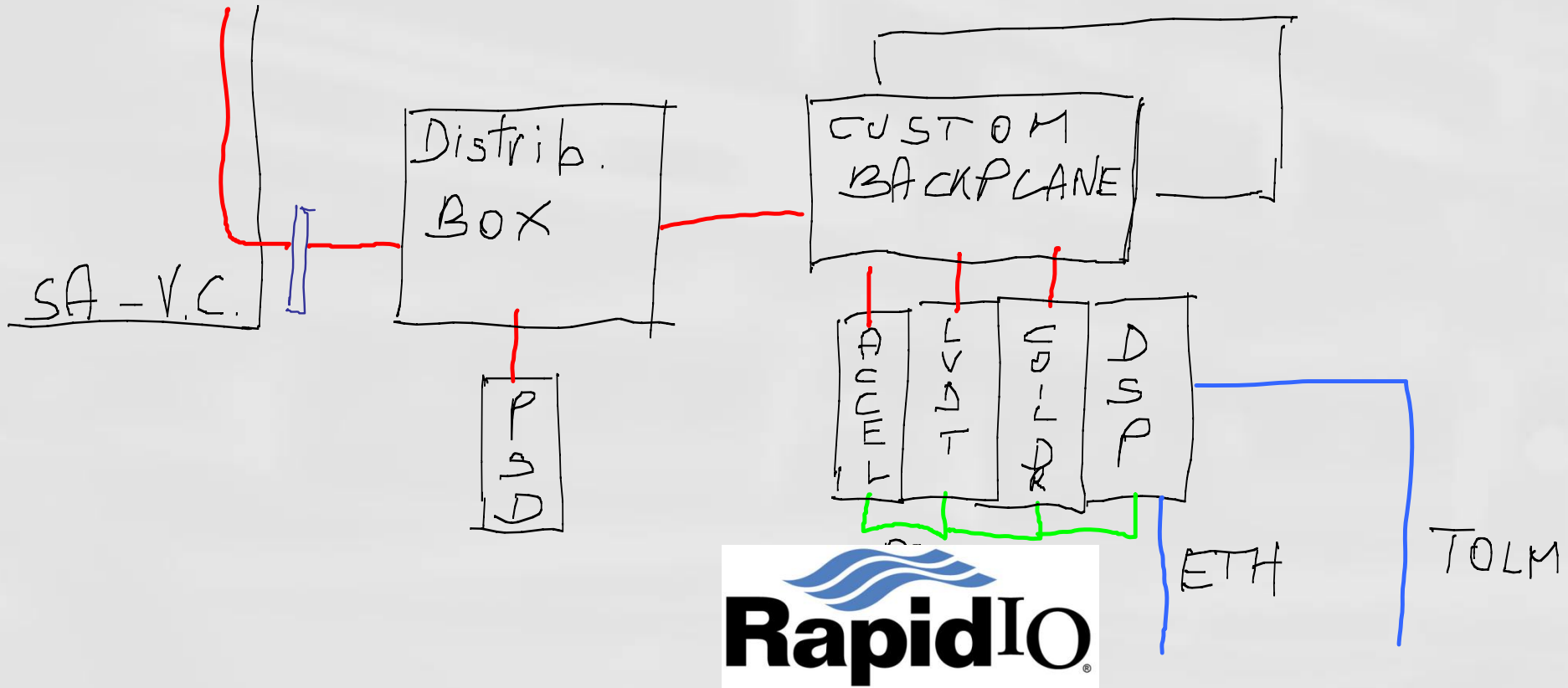

...[continued]

- All electronics in Eurocard 6U crates located next to the tower.
- No CPU (RIOs)
 - Direct communication with DSP via Ethernet
- No VME
 - Communication among boards via RapidIO

Reuse Blocks

- Each board is composed by a small subset of basic blocks
 - DSP block
 - Supervising, processing and communication
 - Data Conversion block
 - ADC-DAC + controlling FPGA and basic analog circuits
 - Analog block
 - Specific for each board

Development Plan

● Manpower

- INFN Pisa – 3-4 FTE
- EGO – 0.5 FTE (t.b.c.) + 1 FTE (software, t.b.c.)
- Poland ???

● Organization

- Each “Reuse Block” has one supervisor
- Board merging by fewer persons (Alberto, Carlo)
- Extensive use of firms for components procurement, assembly and preliminary tests.

Short Term Planning

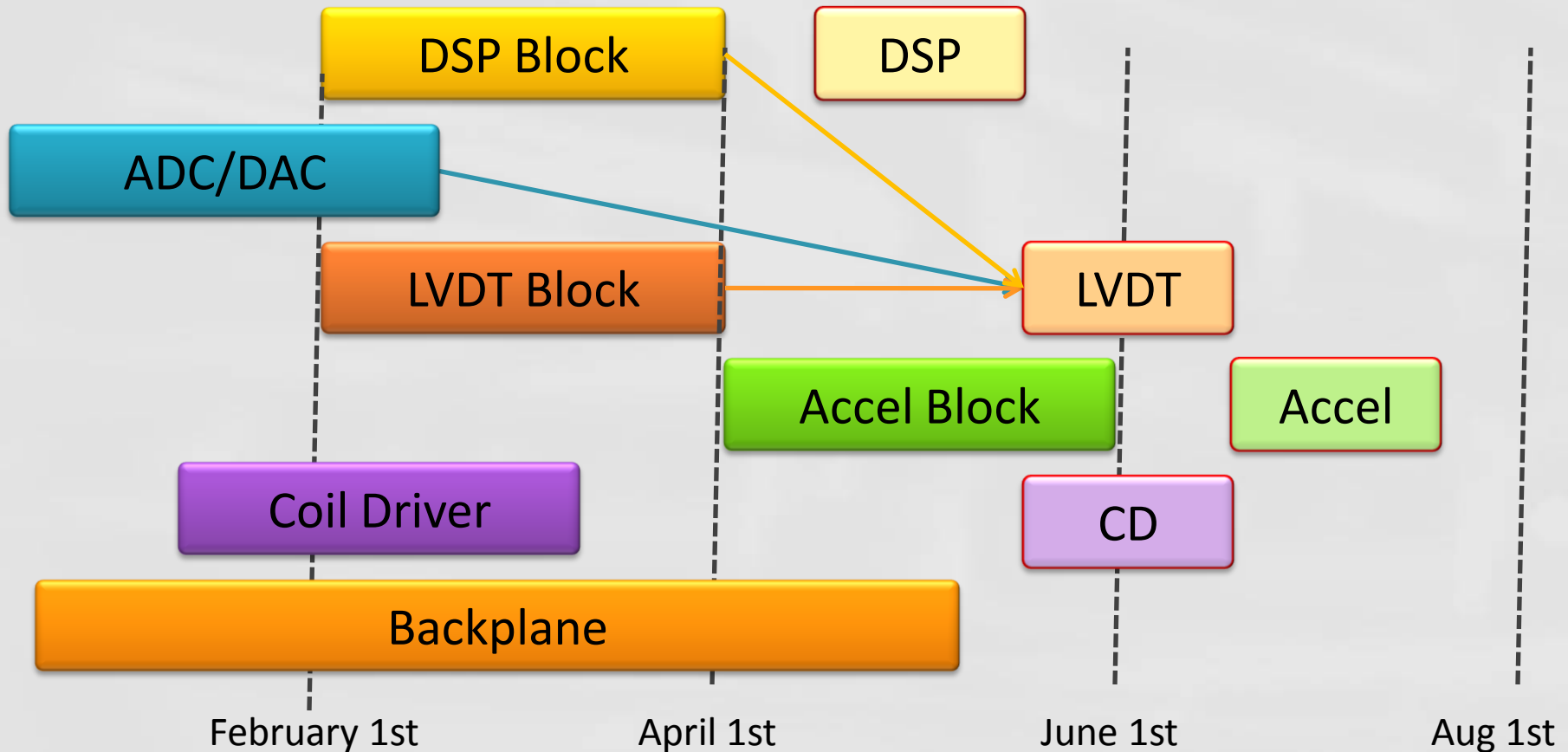

- All orders out within the end of July (2012 😊)

Mode Cleaner

Tentative installation plan

- MC activities will start in March (t.b.c.)
 - Need LVDT readout during SA disassembly
 - Need a first control unit within the end of 2012
 - Test piezo (t.b.c.)
 - Test F7 sensors/actuators(t.b.c.)
 - ...
- So many things to do, so little time

Prototype DSP carrier

- Development of a carrier board for a commercial DSP mezzanine and one TOLM

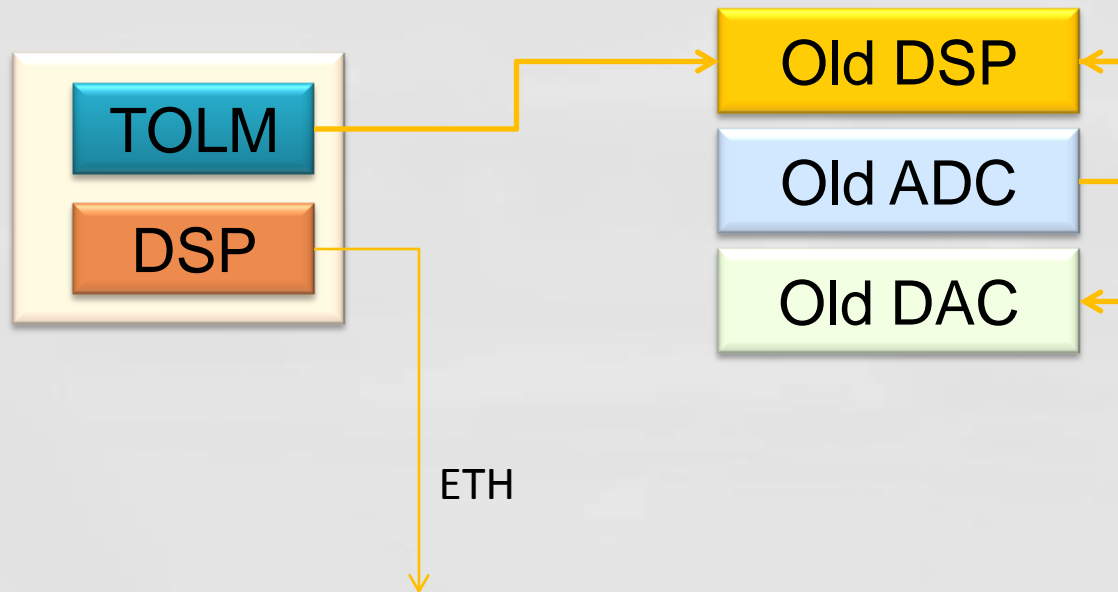

RapidIO

