

CiA 301



Application layer and communication profile

Version: 4.0.2
13 February 2002

© CAN in Automation (CiA) e. V.

HISTORY

Date	Changes
June 1999	<p>Document completely revised;</p> <p>Summary of major changes:</p> <ul style="list-style-type: none">• Object Dictionary structure reviewed• Object services and NMT services included (former in CiA DS-201 .. CiA DS-207 specified)• Data type definitions included (former in CiA DS-201 .. CiA DS-207 specified) and extended• Boot Up Message specified• Optional Heartbeat specified• Additional Emergency error codes specified• Additional SDO abort codes specified• Timer-driven PDO transmission specified• PDO Communication parameter enhanced• PDO Mapping procedure clarified• SDO Block transfer specified• Pre-defined Identifier set extended
June 2000	<ul style="list-style-type: none">• correction of some typing errors• clarification of some descriptions• Appendix:<ul style="list-style-type: none">• Device configuration• OS command and prompt• Multiplexed PDOs• Modular CANopen devices• Error behaviour
February 2002	<ul style="list-style-type: none">• errata sheet included• chapter '11.6.2. Error behaviour object' – wrong reference changed• default value changed from 'No' to '(device profile dependent)' for inhibit time and event timer at definition of TPDO• chapter '9.4.4. Restricted COB-Ids' added• default value changed from 'No' to 'disabled' for COB-ID Client -> Server and COB-ID Server -> Client at definition of Server SDO Parameter for Index 1201h – 127Fh• default value changed from 'No' to 'disabled' for COB-ID Client -> Server and COB-ID Server -> Client at definition of Client SDO Parameter• 'All client SDOs are invalid by default (invalid bit – see ...)' added• 'A000h – BFFFh – Standardised Interface Profile Area' added at table 1• figure 49 changed – structure of the Initialisation state.• annex A edited

General information on licensing and patents

CAN in AUTOMATION (CiA) calls attention to the possibility that some of the elements of this CiA specification may be subject of patent rights. CiA shall not be responsible for identifying any or all such patent rights.

Because this specification is licensed free of charge, there is no warranty for this specification, to the extent permitted by applicable law. Except when otherwise stated in writing the copyright holder and/or other parties provide this specification "as is" without warranty of any kind, either expressed or implied, including, but not limited to, the implied warranties of merchantability and fitness for a particular purpose. The entire risk as to the correctness and completeness of the specification is with you. Should this specification prove failures, you assume the cost of all necessary servicing, repair or correction.

Trademarks

CANopen® and CiA® are registered community trademarks of CAN in Automation. The use is restricted for CiA members or owners of CANopen vendor ID. More detailed terms for the use are available from CiA.

© CiA 2002

All rights reserved. Unless otherwise specified, no part of this publication may be reproduced or utilized in any form or by any means, electronic or mechanical, including photocopying and microfilm, without permission in writing from CiA at the address below.

CAN in Automation e. V.
Kontumazgarten 3
DE - 90429 Nuremberg, Germany
Tel.: +49-911-928819-0
Fax: +49-911-928819-79
Url: www.can-cia.org
Email: headquarters@can-cia.org

CONTENTS

1	TABLES	7
2	FIGURES	9
3	SCOPE	11
4	REFERENCES	12
4.1	Normative references	12
4.2	Informative references	12
5	DEFINITIONS AND ABBREVIATIONS	13
5.1	Abbreviations	13
6	MODELING	15
6.1	Reference Model	15
6.2	Device Model	16
6.2.1	General	16
6.2.2	The Object Dictionary	17
6.3	Communication Model	18
6.3.1	Master/Slave relationship	19
6.3.2	Client/Server relationship	20
6.3.3	Producer/Consumer relationship - Pull/Push model	20
7	PHYSICAL LAYER	21
7.1	Transceiver	21
7.2	Bit rates and timing	21
8	DATA LINK LAYER	23
8.1	CAN Frame Type	23
9	APPLICATION LAYER	24
9.1	Data Types and Encoding Rules	24
9.1.1	General Description of Data Types and Encoding Rules	24
9.1.2	Data Type Definitions	24
9.1.3	Bit Sequences	25

9.1.4	Basic Data Types	26
9.1.5	Compound Data Types	29
9.1.6	Extended Data Types	29
9.2	Communication Objects	30
9.2.1	Process Data Object (PDO)	30
9.2.2	Service Data Object (SDO)	34
9.2.3	Synchronisation Object (SYNC)	59
9.2.4	Time Stamp Object (TIME)	60
9.2.5	Emergency Object (EMCY)	61
9.2.6	Network Management Objects	64
9.3	Synchronisation of the SYNC Consumer	72
9.3.1	Transmission of Synchronous PDO Messages	72
9.3.2	Optional High Resolution Synchronisation Protocol	73
9.4	Network Initialisation and System Boot-Up	75
9.4.1	Initialisation Procedure	75
9.4.2	NMT State Machine	75
9.4.3	Pre-Defined Connection Set	78
9.5	Object Dictionary	80
9.5.1	General Structure of the Object Dictionary	80
9.5.2	Dictionary Components	81
9.5.3	Data Type Entry Specification	81
9.5.4	Specification of Predefined Complex Data Types	83
9.6	Communication Profile Specification	85
9.6.1	Detailed Object Specification	85
9.6.2	Overview Object Dictionary Entries for Communication	85
9.6.3	Detailed Specification of Communication Profile specific Objects	87
10	IMPLEMENTATION RECOMMENDATIONS	115
11	ANNEX A (NORMATIVE)	116
11.1	Additional object dictionary entries	117
11.2	Device configuration	118
11.2.1	Boot-up configuration process	118

CONTENTS	CANopen	CiA
11.2.2	EDS storage	119
11.3	OS command and prompt.....	121
11.3.1	OS command	121
11.3.2	OS debugger interface	123
11.3.3	OS prompt	125
11.4	Multiplexed PDOs.....	127
11.4.1	MPDO Protocol	127
11.4.2	Object dictionary entries	128
11.4.3	Implementing MPDOs	130
11.4.4	Groups, security and network configuration tools	130
11.4.5	Indication of MPDO capability in the EDS.....	130
11.5	Additional functionality for modular CANopen devices.....	131
11.5.1	Background	131
11.5.2	Modular Devices	131
11.6	Additional communication objects.....	133
11.6.1	Emergency consumer object	133
11.6.2	Error behaviour object	134
12	INDEX.....	136

1 TABLES

Table 1: Object Dictionary Structure	17
Table 2: Recommended Bit Timing Settings	21
Table 3: Write PDO	32
Table 4: Read PDO	32
Table 5: SDO Download	36
Table 6: Initiate SDO Download	36
Table 7: Download SDO Segment	37
Table 8: SDO Upload	37
Table 9: Initiate SDO Upload	38
Table 10: Upload SDO Segment	38
Table 11: Abort SDO Transfer	38
Table 12: SDO Block Download	39
Table 13: Initiate SDO Block Download	39
Table 14: Download SDO Block	40
Table 15: End SDO Block Download	40
Table 16: SDO Block Upload	41
Table 17: Initiate SDO Block Upload	41
Table 18: Upload SDO Block	42
Table 19: End SDO Block Upload	42
Table 20: SDO abort codes	49
Table 21: Emergency Error Codes	61
Table 22: Start Remote Node	64
Table 23: Stop Remote Node	64
Table 24: Enter Pre-Operational	64
Table 25: Reset Node	65
Table 26: Reset Communication	65
Table 27: Node Guarding Event	66
Table 28: Life Guarding Event	66
Table 29: Heartbeat Event	66
Table 30: Bootup Event	66
Table 31: Trigger for State Transition	76
Table 32: States and Communication Objects	78
Table 33: Broadcast Objects of the Pre-defined Connection Set	79
Table 34: Peer-to-Peer Objects of the Pre-defined Connection Set	79
Table 35: Restricted COB-IDs	79
Table 36: Format of Object Dictionary Headings	80
Table 37: Object Dictionary Object Definitions	80
Table 38: Access Attributes for Data Objects	81
Table 39: Object Dictionary Data Types	81
Table 40: complex data type example	83

TABLES	CANopen	CiA
Table 41: PDO Communication Parameter Record		84
Table 42: PDO Mapping Parameter Record.....		84
Table 43: SDO Parameter Record		84
Table 44: Identity Record		84
Table 45: Format of an Object Description		85
Table 46: Object Value Description Format.....		85
Table 47: Standard Objects		85
Table 48: Structure of the Error Register		88
Table 49: Description of SYNC COB-ID entry		90
Table 50: Structure of read access		94
Table 51: Structure of restore read access.....		97
Table 52: Description of TIME COB-ID entry		98
Table 53: Description of EMCY COB-ID entry		100
Table 54: Description of SDO COB-ID entry		104
Table 55: Description of PDO COB-ID entry		107
Table 56: Description of transmission type.....		107

2 FIGURES

Figure 1: Reference Model	15
Figure 2: Service Types	16
Figure 3: Device Model	17
Figure 4: Unconfirmed Master Slave Communication	19
Figure 5: Confirmed Master Slave Communication	19
Figure 6: Client/Server Communication	20
Figure 7: Push model	20
Figure 8: Pull model.....	20
Figure 9: Transfer Syntax for Bit Sequences.....	26
Figure 10: Transfer syntax for data type UNSIGNEDn.....	27
Figure 11: Transfer syntax for data type INTEGERn	27
Figure 12: Transfer syntax of data type REAL32	28
Figure 13: Synchronous and Asynchronous Transmission	31
Figure 14: Write PDO Protocol	33
Figure 15: Read PDO Protocol.....	33
Figure 16: Download SDO Protocol	43
Figure 17: Initiate SDO Download Protocol.....	44
Figure 18: Download SDO Segment Protocol.....	45
Figure 19: Upload SDO Protocol	46
Figure 20: Initiate SDO Upload Protocol.....	47
Figure 21: Upload SDO Segment Protocol.....	48
Figure 22: Abort SDO Transfer Protocol.....	49
Figure 23: SDO Block Download Protocol.....	51
Figure 24: Initiate SDO Block Download Protocol.....	52
Figure 25: Download SDO Block Segment.....	53
Figure 26: End SDO Block Download Protocol	54
Figure 27: Upload SDO Block Protocol.....	55
Figure 28: Initiate SDO Block Upload Protocol	56
Figure 29: Upload SDO Block Segment Protocol	57
Figure 30: End SDO Block Upload Protocol.....	58
Figure 31: SYNC Protocol.....	59
Figure 32: TIME Protocol	60
Figure 33: Emergency State Transition Diagram	62
Figure 34: Emergency Object Data	62
Figure 35: Emergency Object Protocol	63
Figure 36: Start Remote Node Protocol.....	67
Figure 37: Stop Remote Node Protocol	67
Figure 38: Enter Pre-Operational Protocol	68
Figure 39: Reset Node Protocol	68
Figure 40: Reset Communication Protocol.....	69

FIGURES	CANopen	CiA
Figure 41: Node Guarding Protocol.....		70
Figure 42: Heartbeat Protocol.....		71
Figure 43: Bootup Protocol		72
Figure 44: Bus Synchronisation and Actuation		73
Figure 45: Bus Synchronisation and Sampling		73
Figure 46: Optional High Resolution Synchronisation Protocol		74
Figure 47: Flow Chart of the Network Initialisation Process.....		75
Figure 48: State Diagram of a Device		76
Figure 49: Structure of the Initialisation state		77
Figure 50: Identifier allocation scheme for the pre-defined connection set.....		79
Figure 51: structure sub-index FFh		83
Figure 52: Structure of the Device Type Parameter		87
Figure 53: Structure of the pre-defined error field		89
Figure 54: Structure of SYNC COB-ID entry		90
Figure 55: Storage write access signature		94
Figure 56: Storage read access structure.....		94
Figure 57: Restoring write access signature		96
Figure 58: restore procedure		96
Figure 59: Restoring default values read access structure		96
Figure 60: Structure of TIME COB-ID entry.....		98
Figure 61: Structure of the EMCY Identifier entry		99
Figure 62: Structure of Consumer Heartbeat Time entry		101
Figure 63: Structure of Revision number		102
Figure 64: Structure of SDO COB-ID entry.....		104
Figure 65: Structure of PDO COB-ID entry.....		107
Figure 66: Structure of PDO Mapping Entry.....		110
Figure 67: Principle of PDO mapping.....		111

3 SCOPE

This Part of EN 50325 specifies the following particular requirements for CANopen:

- (1) Requirements for interfaces between controllers and switching elements;
- (2) Normal service conditions for devices;
- (3) Constructional and performance requirements.

4 REFERENCES

4.1 Normative references

- EN 50325-1: 2002 Industrial communications subsystem based on ISO 11898 (CAN) for controller-device interfaces
Part 1: General requirements
- EN 61131-3: 1993 Programmable controllers
Part 3: Programming languages
- ISO 7498-1: 1994 Information technology - Open Systems Interconnection - Basic Reference Model: The Basic Model
- ISO 8859: 1998 Information technology - 8-bit single-byte coded graphic character sets
- ISO 11898: 1993 Road vehicles - Interchange of digital information - Controller area network (CAN) for high-speed communication
- ISO 646: 1991 Information technology - ISO 7-bit coded character set for information interchange

4.2 Informative references

- IEEE 754: 1985 Standard for binary floating-point arithmetic

5 DEFINITIONS AND ABBREVIATIONS

5.1 Abbreviations

ARQ:

Automatic Repeat Request.

CAN:

Controller Area Network is an internally standardized serial bus system..

COB:

Communication Object. A unit of transportation in a CAN network. Data must be sent across a CAN Network inside a COB. There are 2048 different COB's in a CAN network. A COB can contain at most 8 bytes of data.

COB-ID:

Each COB is uniquely identified in a CAN network by a number called the COB Identifier (COB-ID). The COB-ID determines the priority of that COB for the MAC sub-layer.

Remote COB:

A COB whose transmission can be requested by another device.

CRC:

Cyclic Redundancy Check.

CSDO:

Client SDO.

LLC:

Logical Link Control. One of the sub-layers of the Data Link Layer in the CAN Reference Model that gives the user an interface that is independent from the underlying MAC layer.

MAC:

Medium Access Control. One of the sub-layers of the Data Link Layer in the CAN Reference Model that controls who gets access to the medium to send a message.

MDI:

Medium Dependent Interface. One of the sub-layers of the Physical Layer in the CAN Reference Model that specifies the mechanical and electrical interface between the medium and a module.

NMT:

Network Management. One of the service elements of the application layer in the CAN Reference Model. The NMT serves to configure, initialise, and handle errors in a CAN network.

Node-ID:

The Node-ID of the NMT Slave has to be assigned uniquely, or 0. If 0, the protocol addresses all NMT Slaves.

OSI:

Open Systems Interconnection.

PDO:

Process Data Object.

PLS:

Physical Layer Signalling. One of the sub-layers of the Physical Layer in the CAN Reference Model that specifies the bit representation, timing and synchronisation.

PMA:

Physical Medium Attachment. One of the sub-layers of the Physical Layer in the CAN Reference Model that specifies the functional circuitry for bus line transmission/reception and may provide means for failure detection.

RPDO:
Receive PDO.

SDO:
Service Data Object.

SSDO:
Server SDO.

SYNC:
Synchronisation Object.

TPDO:
Transmit PDO.

6 MODELING

CAN-based networks use the following reference model, device model, and communication model.

6.1 Reference Model

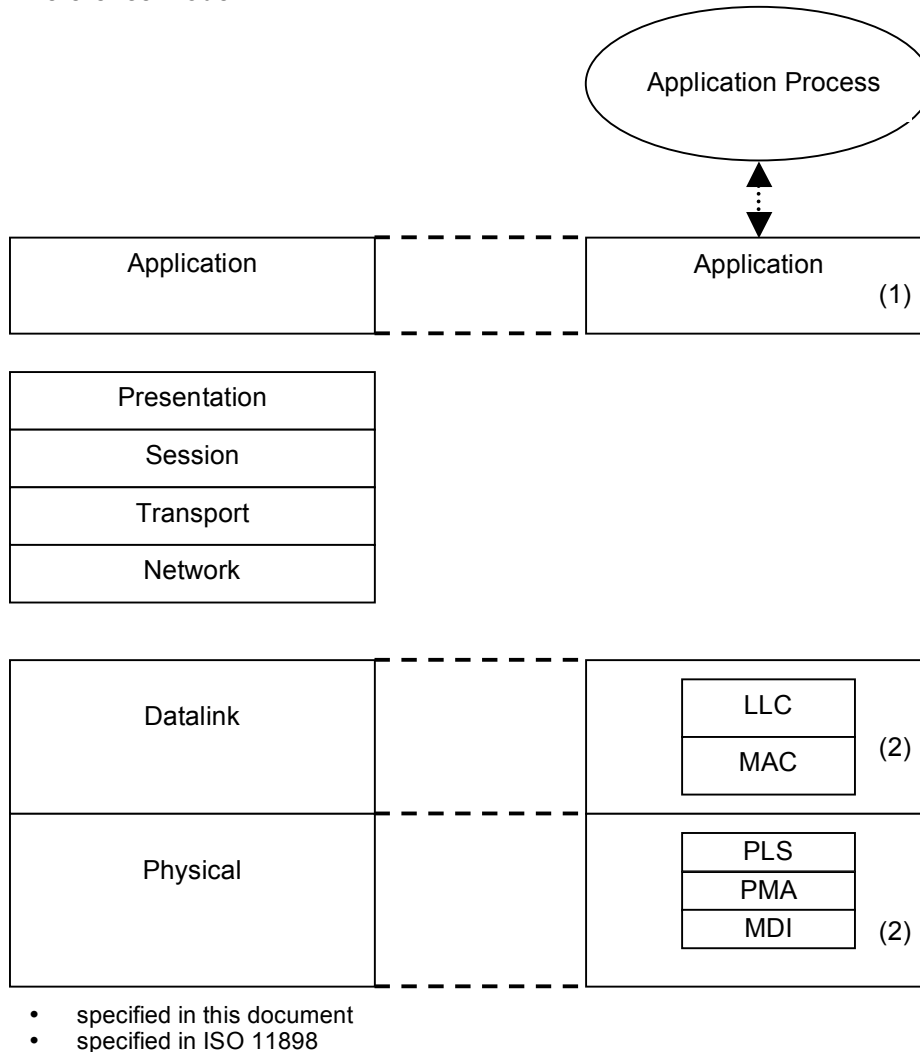

Figure 1: Reference Model

The communication concept can be described similar to the ISO-OSI Reference Model (left side of figure).

Application Layer:

The Application Layer comprises a concept to configure and communicate real-time-data as well as the mechanisms for synchronization between devices. The functionality the application layer offers to an application is logically divided over different *service objects* in the application layer. A service object offers a specific functionality and all the related services. These services are described in the *Service Specification* of that service object.

Applications interact by invoking services of a service object in the application layer. To realize these services, this object exchanges data via the CAN Network with (a) peer service object(s) via a protocol. This protocol is described in the *Protocol Specification* of that service object.

Service Primitives:

Service primitives are the means by which the application and the application layer interact. There are four different primitives:

- a *request* is issued by the application to the application layer to request a service
- an *indication* is issued by the application layer to the application to report an internal event detected by the application layer or indicate that a service is requested

- a *response* is issued by the application to the application layer to respond to a previous received indication
- a *confirmation* is issued by the application layer to the application to report the result of a previously issued request.

Application Layer Service Types

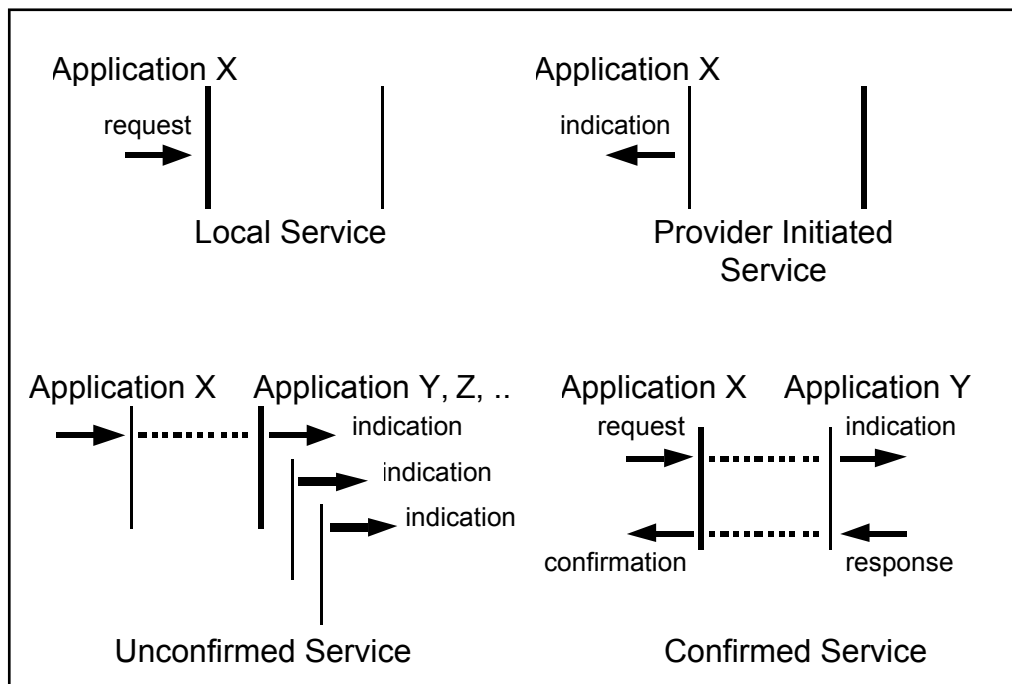

Figure 2: Service Types

A *service type* defines the primitives that are exchanged between the application layer and the co-operating applications for a particular service of a service object.

- A *local service* involves only the local service object. The application issues a request to its local service object that executes the requested service without communicating with (a) peer service object(s).
- An *unconfirmed service* involves one or more peer service objects. The application issues a request to its local service object. This request is transferred to the peer service object(s) that each pass it to their application as an indication. The result is not confirmed back.
- A *confirmed service* can involve only one peer service object. The application issues a request to its local service object. This request is transferred to the peer service object that passes it to the other application as an indication. The other application issues a response that is transferred to the originating service object that passes it as a confirmation to the requesting application.
- A *provider initiated service* involves only the local service object. The service object (being the service provider) detects an event not solicited by a requested service. This event is then indicated to the application.

Unconfirmed and confirmed services are collectively called *remote services*.

6.2 Device Model

6.2.1 General

A device is structured like the following (see Figure 3):

- **Communication** – This function unit provides the communication objects and the appropriate functionality to transport data items via the underlying network structure.
- **Object Dictionary** – The Object Dictionary is a collection of all the data items which have an influence on the behavior of the application objects, the communication objects and the state machine used on this device.
- **Application** – The application comprises the functionality of the device with respect to the interaction with the process environment.

Thus the Object Dictionary serves as an interface between the communication and the application. The complete description of a device's application with respect to the data items in the Object Dictionary is named *device profile*.

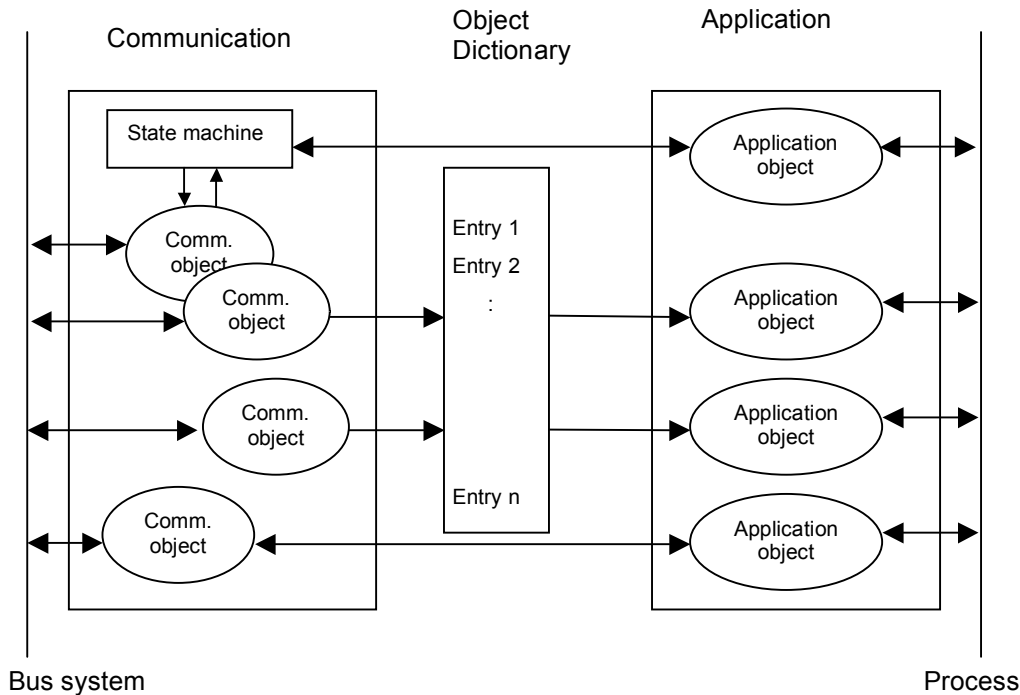

Figure 3: Device Model

6.2.2 The Object Dictionary

The most important part of a device profile is the Object Dictionary description. The Object Dictionary is essentially a grouping of objects accessible via the network in an ordered pre-defined fashion. Each object within the dictionary is addressed using a 16-bit index.

The overall layout of the standard Object Dictionary is shown below. This layout closely conforms with other industrial serial bus system concepts:

Table 1: Object Dictionary Structure

Index (hex)	Object
0000	not used
0001-001F	Static Data Types
0020-003F	Complex Data Types
0040-005F	Manufacturer Specific Complex Data Types
0060-007F	Device Profile Specific Static Data Types
0080-009F	Device Profile Specific Complex Data Types
00A0-0FFF	Reserved for further use
1000-1FFF	Communication Profile Area
2000-5FFF	Manufacturer Specific Profile Area
6000-9FFF	Standardised Device Profile Area
A000-BFFF	Standardised Interface Profile Area
C000-FFFF	Reserved for further use

The Object Dictionary may contain a maximum of 65536 entries which are addressed through a 16-bit index.

The Static Data Types at indices 0001h through 001Fh contain type definitions for standard data types like BOOLEAN, INTEGER, floating point, string, etc. These entries are included for reference only, they cannot be read or written.

Complex Data Types at indices 0020h through 003Fh are pre-defined structures that are composed of standard data types and are common to all devices.

Manufacturer Specific Complex Data Types at indices 0040h through 005Fh are structures composed of standard data types but are specific to a particular device.

Device Profiles may define additional data types specific to their device type. The static data types defined by the device profile are listed at indices 0060h - 007Fh, the complex ones at indices 0080h - 009Fh.

A device may optionally provide the structure of the supported complex data types (indices 0020h - 005Fh and 0080h - 009Fh) at read access to the corresponding index. Sub-index 0 then provides the number of entries at this index, and the following sub-indices contain the data type encoded as UNSIGNED16 according to Table 39.

The Communication Profile Area at indices 1000h through 1FFFh contains the communication specific parameters for the CAN network. These entries are common to all devices.

The standardised device profile area at indices 6000h through 9FFFh contains all data objects common to a class of devices that can be read or written via the network. The device profiles may use entries from 6000h to 9FFFh to describe the device parameters and the device functionality. Within this range up to 8 different devices can be described. In such a case the devices are denominated Multiple Device Modules. Multiple Device Modules are composed of up to 8 device profile segments. By this feature it is possible to build devices with multiple functionality. The different device profile entries are shifted with 800h.

For Multiple Device Modules the object range 6000_h to 67FF_h is shifted as follows:

6000h to 67FFh	device 0
6800h to 6FFFh	device 1
7000h to 77FFh	device 2
7800h to 7FFFh	device 3
8000h to 87FFh	device 4
8800h to 8FFFh	device 5
9000h to 97FFh	device 6
9800h to 9FFFh	device 7

The PDO distribution shall be used for every segment of a Multiple Device Module with an offset of 64, e.g. the first PDO of the second segment gets the number 65. In this way a system with a maximum of 8 segments is supported.

The Object Dictionary concept caters for optional device features which means a manufacturer does not have to provide certain extended functionality on his devices but if he wishes to do so he must do it in a pre-defined fashion.

Space is left in the Object Dictionary at indices 2000h through 5FFFh for truly manufacturer-specific functionality.

6.2.2.1 Index and Sub-Index Usage

A 16-bit index is used to address all entries within the Object Dictionary. In case of a simple variable the index references the value of this variable directly. In case of records and arrays however, the index addresses the whole data structure.

To allow individual elements of structures of data to be accessed via the network a sub-index is defined. For single Object Dictionary entries such as an UNSIGNED8, BOOLEAN, INTEGER32 etc. the value for the sub-index is always zero. For complex Object Dictionary entries such as arrays or records with multiple data fields the sub-index references fields within a data-structure pointed to by the main index. The fields accessed by the sub-index can be of differing data types.

6.3 Communication Model

The communication model specifies the different communication objects and services and the available modes of message transmission triggering.

The communication model supports the transmission of synchronous and asynchronous messages. By means of synchronous message transmission a network wide coordinated data acquisition and actuation is possible. The synchronous transmission of messages is supported by pre-defined communication objects (Sync message, time stamp message). Synchronous messages are transmitted with respect to a pre-defined synchronization message, asynchronous message may be transmitted at any time.

Due to the event character of the underlying communication mechanism it is possible to define inhibit times for the communication. To guarantee that no starvation on the network occurs for data objects with low priorities, data objects can be assigned an inhibit time. The inhibit-time of a data object defines the minimum time that has to elapse between two consecutive invocations of a transmission service for that data object. Inhibit-times can be assigned by the application.

With respect to their functionality, three types of communication relationships are distinguished

- Master/Slave relationship (Figure 4 and Figure 5)
- Client/Server relationship (Figure 6)
- Producer/Consumer relationship (Figure 7 and Figure 8)

6.3.1 Master/Slave relationship

At any time there is exactly one device in the network serving as a master for a specific functionality. All other devices in the network are considered as slaves. The master issues a request and the addressed slave(s) respond(s) if the protocol requires this behavior.

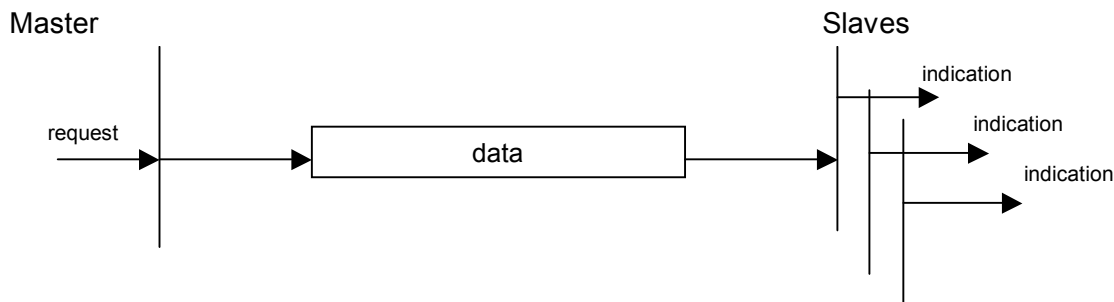

Figure 4: Unconfirmed Master Slave Communication

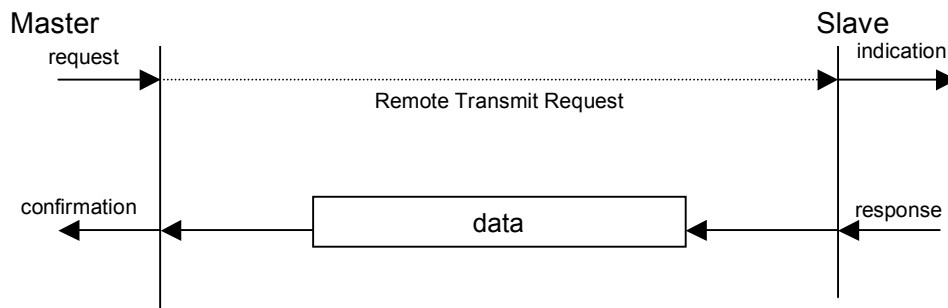

Figure 5: Confirmed Master Slave Communication

6.3.2 Client/Server relationship

This is a relationship between a single client and a single server. A client issues a request (upload/download) thus triggering the server to perform a certain task. After finishing the task the server answers the request.

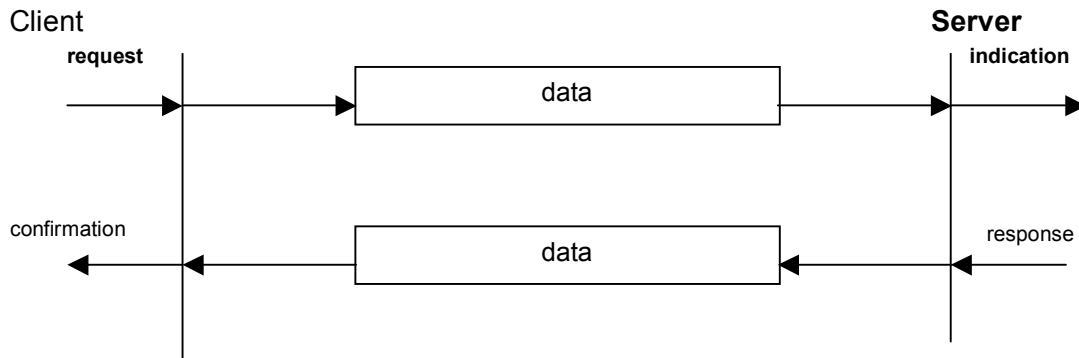

Figure 6: Client/Server Communication

6.3.3 Producer/Consumer relationship - Pull/Push model

The producer/consumer relationship model involves a producer and zero or more consumer(s). The push model is characterized by an unconfirmed service requested by the producer. The pull model is characterized by a confirmed service requested by the consumer.

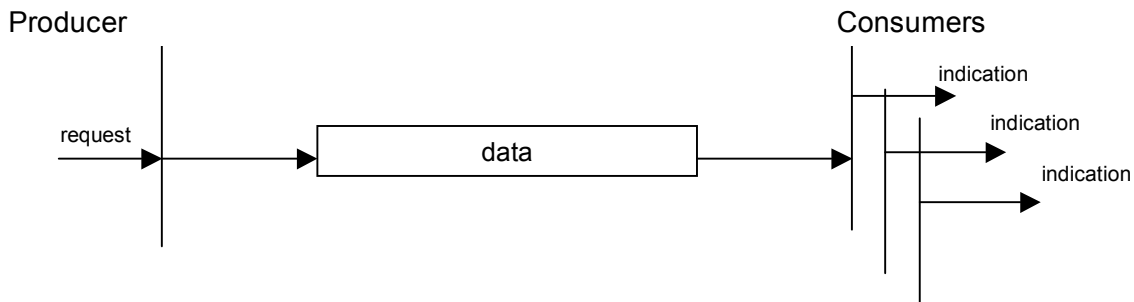

Figure 7: Push model

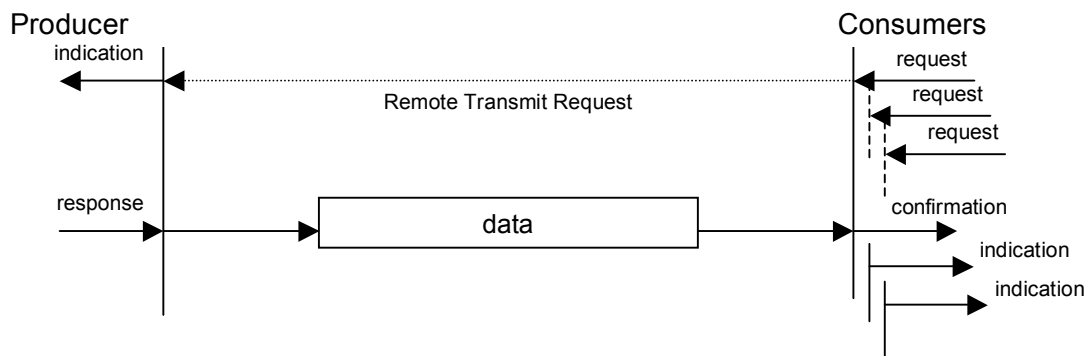

Figure 8: Pull model

7 PHYSICAL LAYER

The physical medium for devices is a differentially driven two-wire bus line with common return according to high-speed transmission specification in ISO 11898.

7.1 Transceiver

Using the high-speed transceiver according to ISO 11898 the maximum rating for V_{CAN_H} and V_{CAN_L} shall be +16V. Galvanic isolation between bus nodes is optional. It is recommended to use a transceiver that is capable of sustaining mis-connection of any of the wires of the connector including the optional V+ voltages of up to 30V.

7.2 Bit rates and timing

The recommended bit rates and corresponding bit timing recommendations⁽⁴⁾ are listed in Table 2. One of these bit rates has to be supported.

Table 2: Recommended Bit Timing Settings

Bit rate Bus length ⁽¹⁾	Nominal bit time t_b	Number of time quanta per bit	Length of time quantum t_q	Location of sample point
1 Mbit/s 25 m	1 μ s	8	125 ns	6 t_q (750 ns)
800 kbit/s 50 m	1,25 μ s	10	125 ns	8 t_q (1 μ s)
500 kbit/s 100 m	2 μ s	16	125 ns	14 t_q (1,75 μ s)
250 kbit/s 250 m ⁽²⁾	4 μ s	16	250 ns	14 t_q (3,5 μ s)
125 kbit/s 500 m ⁽²⁾	8 μ s	16	500 ns	14 t_q (7 μ s)
50 kbit/s 1000 m ⁽³⁾	20 μ s	16	1,25 μ s	14 t_q (17,5 μ s)
20 kbit/s 2500 m ⁽³⁾	50 μ s	16	3,125 μ s	14 t_q (43,75 μ s)
10 kbit/s 5000 m ⁽³⁾	100 μ s	16	6,25 μ s	14 t_q (87,5 μ s)

The table entries are an example based on the follow acceptance:

Oscillator frequency	16 MHz +/-0.1% (1000 ppm)	
Sampling mode	Single sampling	SAM = 0
Synchronisation mode	Recessive to dominant edges only	SYNC = 0
Synchronisation jump width	1 * t_q	SJW = 0
Phase Segment 2	2 * t_q	TSEG2 = 1

Note 1: Rounded bus length estimation (worst case) on basis 5 ns/m propagation delay and a total effective device internal in-out delay as follows:

1M - 800 kbit/s:	210 ns
500 - 250 kbit/s:	300 ns (includes 2 * 40 ns for optocouplers)
125 kbit/s:	450 ns (includes 2 * 100 ns for optocouplers)
50 - 10 kbit/s:	1,5 t_q ; Effective delay = delay recessive to dominant plus dominant to recessive divided by two.

Note 2: For bus length greater than about 200 m the use of optocouplers is recommended. If optocouplers are placed between CAN controller and transceiver this affects the maximum bus length depending upon the propagation delay of the optocouplers i.e. -4m per 10 ns propagation delay of employed optocoupler type.

Note 3: For bus length greater than about 1 km bridge or repeater devices may be needed.

Note 4: The bit timings in the table are calculated for an oscillator frequency of 16 MHz. If another oscillator is used the number of time quanta may be different. Nevertheless the location of the sample point shall be as near as possible at the

recommended sample point.

8 DATA LINK LAYER

The described networks are based on a data link layer and its sub-layers according to ISO 11898.

8.1 CAN Frame Type

This specification is based on the CAN Standard Frames with 11-bit Identifier Field. It is not required to support the CAN Extended Frame with 29-bit Identifier Field.

However, as certain applications may require the usage of the extended frame with 29-bit Identifier Field the network can be operated in this mode as well if it is supported by all nodes.

9 APPLICATION LAYER

9.1 Data Types and Encoding Rules

9.1.1 General Description of Data Types and Encoding Rules

To be able to exchange meaningful data across the CAN network, the format of this data and its meaning have to be known by the producer and consumer(s). This specification models this by the concept of data types.

The encoding rules define the representation of values of data types and the CAN network transfer syntax for the representations. Values are represented as bit sequences. Bit sequences are transferred in sequences of octets (bytes). For numerical data types the encoding is little endian style as shown in Figure 9.

Applications often require data types beyond the basic data types. Using the compound data type mechanism the list of available data types can be extended. Some general extended data types are defined as “Visible String” or “Time of Day” for example (see 9.1.6.2 and 9.1.6.4). The compound data types are a means to implement user defined “DEFTYPES” in the terminology of this specification and not “DEFSTRUCTS” (see Table 37: Object Dictionary Object Definitions).

9.1.2 Data Type Definitions

A data type determines a relation between values and encoding for data of that type. Names are assigned to data types in their type definitions. The syntax of data and data type definitions is as follows (see EN 61131-3).

data_definition	::= type_name data_name
type_definition	::= constructor type_name
constructor	::= compound_constructor basic_constructor
compound_constructor	::= array_constructor structure_constructor
array_constructor	::= 'ARRAY' '[' length ']' 'OF' type_name
structure_constructor	::= 'STRUCT' 'OF' component_list
component_list	::= component { ',' component }
component	::= type_name component_name
basic_constructor	::= 'BOOLEAN' 'VOID' bit_size 'INTEGER' bit_size 'UNSIGNED' bit_size 'REAL32' 'REAL64' 'NIL'
bit_size	::= '1' '2' <...> '64'
length	::= positive_integer
data_name	::= symbolic_name
type_name	::= symbolic_name
component_name	::= symbolic_name
symbolic_name	::= letter { ['_'] (letter digit) }
positive_integer	::= ('1' '2' <...> '9') { digit }
letter	::= 'A' 'B' <...> 'Z' 'a' 'b' <...> 'z'
digit	::= '0' '1' <...> '9'

Recursive definitions are not allowed.

The data type defined by `type_definition` is called basic (res.~compound) when the constructor is `basic_constructor` (res. `compound_constructor`).

9.1.3 Bit Sequences

9.1.3.1 Definition of Bit Sequences

A bit can take the values 0 or 1. A bit sequence b is an ordered set of 0 or more bits. If a bit sequence b contains more than 0 bits, they are denoted as $b_j, j \geq 0$. Let b_0, \dots, b_{n-1} be bits, n a positive integer. Then

$$b = b_0 b_1 \dots b_{n-1}$$

is called a bit sequence of length $|b| = n$. The empty bit sequence of length 0 is denoted ϵ .

Examples: 10110100, 1, 101, etc. are bit sequences.

The inversion operator (\neg) on bit sequences assigns to a bit sequence

$$b = b_0 b_1 \dots b_{n-1}$$

the bit sequence

$$\neg b = \neg b_0 \neg b_1 \dots \neg b_{n-1}$$

Here $\neg 0 = 1$ and $\neg 1 = 0$ on bits.

The basic operation on bit sequences is concatenation.

Let $a = a_0 \dots a_{m-1}$ and $b = b_0 \dots b_{n-1}$ be bit sequences. Then the concatenation of a and b , denoted ab , is

$$ab = a_0 \dots a_{m-1} b_0 \dots b_{n-1}$$

Example: (10)(111) = 10111 is the concatenation of 10 and 111.

The following holds for arbitrary bit sequences a and b :

$$|ab| = |a| + |b|$$

and

$$\epsilon a = a \epsilon = a$$

9.1.3.2 Transfer Syntax for Bit Sequences

For transmission across a CAN network a bit sequence is reordered into a sequence of octets. Here and in the following hexadecimal notation is used for octets. Let $b = b_0 \dots b_{n-1}$ be a bit sequence with $n \leq 64$. Denote k a non-negative integer such that $8(k-1) < n \leq 8k$. Then b is transferred in k octets assembled as shown in Figure 9. The bits $b_i, i \geq n$ of the highest numbered octet are do not care bits. Octet 1 is transmitted first and octet k is transmitted last. Hence the bit sequence is transferred as follows across the CAN network:

$$b_7, b_6, \dots, b_0, b_{15}, \dots, b_8, \dots$$

octet number	1.	2.	k.
	b ₇ .. b ₀	b ₁₅ .. b ₈	b _{8k-1} .. b _{8k-8}

Figure 9: Transfer Syntax for Bit Sequences

Example:

```

Bit 9      ...      Bit 0
  10 0001 1100
  2h  1h  Ch
                = 21Ch

```

The bit sequence $b = b_0 .. b_9 = 0011\ 1000\ 01$ represents an *UNSIGNED10* with the value 21Ch and is transferred in two octets:
First 1Ch and then 02h.

9.1.4 Basic Data Types

For basic data types "type_name" equals the literal string of the associated constructor (aka *symbolic_name*), e.g.,

```
BOOLEAN BOOLEAN
```

is the type definition for the *BOOLEAN* data type.

9.1.4.1 NIL

Data of basic data type *NIL* is represented by ϵ .

9.1.4.2 Boolean

Data of basic data type *BOOLEAN* attains the values TRUE or FALSE. The values are represented as bit sequences of length 1. The value TRUE (res. FALSE) is represented by the bit sequence 1 (res. 0).

9.1.4.3 Void

Data of basic data type *VOIDn* is represented as bit sequences of length n bit. The value of data of type *VOIDn* is undefined. The bits in the sequence of data of type *VOIDn* must either be specified explicitly or else marked "do not care".

Data of type *VOIDn* is useful for reserved fields and for aligning components of compound values on octet boundaries.

9.1.4.4 Unsigned Integer

Data of basic data type *UNSIGNEDn* has values in the non-negative integers. The value range is 0, ..., 2^n-1 . The data is represented as bit sequences of length n . The bit sequence

$$b = b_0 ... b_{n-1}$$

is assigned the value

$$\text{UNSIGNEDn}(b) = b_{n-1} 2^{n-1} + ... + b_1 2^1 + b_0 2^0$$

Note that the bit sequence starts on the left with the least significant byte.

Example: The value 266 = 10Ah with data type UNSIGNED16 is transferred in two octets across the bus, first 0Ah and then 01h.

The following UNSIGNEDn data types are transferred as shown below:

octet number	1.	2.	3.	4.	5.	6.	7.	8.
UNSIGNED8	b7..b0							
UNSIGNED16	b7..b0	b15..b8						
UNSIGNED24	b7..b0	b15..b8	b23..b16					
UNSIGNED32	b7..b0	b15..b8	b23..b16	b31..b24				
UNSIGNED40	b7..b0	b15..b8	b23..b16	b31..b24	b39..b32			
UNSIGNED48	b7..b0	b15..b8	b23..b16	b31..b24	b39..b32	b47..b40		
UNSIGNED56	b7..b0	b15..b8	b23..b16	b31..b24	b39..b32	b47..b40	b55..b48	
UNSIGNED64	b7..b0	b15..b8	b23..b16	b31..b24	b39..b32	b47..b40	b55..b48	b63..b56

Figure 10: Transfer syntax for data type UNSIGNEDn

9.1.4.5 Signed Integer

Data of basic data type *INTEGERn* has values in the integers. The value range is $-2^{n-1}, \dots, 2^{n-1}-1$. The data is represented as bit sequences of length n . The bit sequence

$$b = b_0 \dots b_{n-1}$$

is assigned the value

$$\text{INTEGER}_n(b) = b_{n-2} 2^{n-2} + \dots + b_1 2^1 + b_0 2^0 \quad \text{if } b_{n-1} = 0$$

and, performing two's complement arithmetic,

$$\text{INTEGER}_n(b) = -\text{INTEGER}_n(\text{^}b) - 1 \quad \text{if } b_{n-1} = 1$$

Note that the bit sequence starts on the left with the least significant bit.

*Example: The value $-266 = \text{FEF6h}$ with data type *INTEGER16* is transferred in two octets across the bus, first *F6h* and then *FEh*.*

The following INTEGERn data types are transferred as shown below:

octet number	1.	2.	3.	4.	5.	6.	7.	8.
INTEGER8	b7..b0							
INTEGER16	b7..b0	b15..b8						
INTEGER24	b7..b0	b15..b8	b23..b16					
INTEGER32	b7..b0	b15..b8	b23..b16	b31..b24				
INTEGER40	b7..b0	b15..b8	b23..b16	b31..b24	b39..b32			
INTEGER48	b7..b0	b15..b8	b23..b16	b31..b24	b39..b32	b47..b40		
INTEGER56	b7..b0	b15..b8	b23..b16	b31..b24	b39..b32	b47..b40	b55..b48	
INTEGER64	b7..b0	b15..b8	b23..b16	b31..b24	b39..b32	b47..b40	b55..b48	b63..b56

Figure 11: Transfer syntax for data type INTEGERn

9.1.4.6 Floating-Point Numbers

Data of basic data types *REAL32* and *REAL64* have values in the real numbers.

The data type *REAL32* is represented as bit sequence of length 32. The encoding of values follows the IEEE 754-1985 Standard for single precision floating-point.

The data type *REAL64* is represented as bit sequence of length 64. The encoding of values follows the IEEE 754-1985 Standard for double precision floating-point numbers.

A bit sequence of length 32 either has a value (finite non-zero real number, ± 0 , $\pm _$) or is NaN (not-a-number). The bit sequence

$$b = b_0 \dots b_{31}$$

is assigned the value (finite non-zero number)

$$\text{REAL32}(b) = (-1)^S 2^{E-127} (1 + F)$$

Here

$S = b_{31}$ is the sign.

$E = b_{30} 2^7 + \dots + b_{23} 2^0$, $0 < E < 255$, is the un-biased exponent.

$F = 2^{-23} (b_{22} 2^{22} + \dots + b_1 2^1 + b_0 2^0)$ is the fractional part of the number.

$E = 0$ is used to represent ± 0 . $E = 255$ is used to represent infinities and NaN's.

Note that the bit sequence starts on the left with the least significant bit.

Example:

$$6.25 = 2^E - 127 (1 + F) \text{ with}$$

$$E = 129 = 2^7 + 2^0 \text{ and}$$

$$F = 2^{-1} + 2^{-4} = 2^{-23} (2^{22} + 2^{19}) \text{ hence the number is represented as:}$$

S	E	F
b_{31}	$b_{30} \dots b_{23}$	$b_{22} \dots b_0$
0	100 0000 1	100 1000 0000 0000 0000 0000

$$6.25 = b_0 \dots b_{31} = 0000\ 0000\ 0000\ 0000\ 0001\ 0011\ 0000\ 0010$$

It is transferred in the following order:

octet number	1.	2.	3.	4.
REAL32	00h	00h	C8h	40h
	b7..b0	b15..b8	b23..b16	b31..b24

Figure 12: Transfer syntax of data type REAL32

9.1.5 Compound Data Types

Type definitions of compound data types expand to a unique list of type definitions involving only basic data types. Correspondingly, data of compound type 'type_name' are ordered lists of component data named 'component_name_i' of basic type 'basic_type_i'.

Compound data types constructors are ARRAY and STRUCT OF.

STRUCT OF

```

    basic_type_1      component_name_1,
    basic_type_2      component_name_2,
    ...
    basic_type_N      component_name_N

```

type_name

ARRAY [length] OF basic_type type_name

The bit sequence representing data of compound type is obtained by concatenating the bit sequences representing the component data.

Assume that the components 'component_name_i' are represented by their bit sequences

$$b(i), \text{ for } i = 1, \dots, N$$

Then the compound data is represented by the concatenated sequence

$$b_0(1) .. b_{n-1}(1) .. b_{n-1}(N).$$

Example:

Consider the data type

STRUCT OF

```

    INTEGER10      x,
    UNSIGNED5      u

```

NewData

Assume $x = -423 = 259h$ and $u = 30 = 1Eh$. Let $b(x)$ and $b(u)$ denote the bit sequences representing the values of x and u , respectively. Then:

$$b(x) = b_0(x) .. b_9(x) = 1001101001$$

$$b(u) = b_0(u) .. b_4(u) = 01111$$

$$b(xu) = b(x) b(u) = b_0(xu) .. b_{14}(xu) = 1001101001 01111$$

The value of the structure is transferred with two octets, first 59h and then 7Ah.

9.1.6 Extended Data Types

The extended data types consist of the basic data types and the compound data types defined in the following subsections.

9.1.6.1 Octet String

The data type OCTET_STRING $length$ is defined below; $length$ is the length of the octet string.

ARRAY [length] OF UNSIGNED8 OCTET_STRING $length$

9.1.6.2 Visible String

The data type VISIBLE_STRING $length$ is defined below. The admissible values of data of type VISIBLE_CHAR are 0h and the range from 20h to 7Eh. The data are interpreted as ISO 646-1973(E) 7-bit coded characters. $length$ is the length of the visible string.

UNSIGNED8 VISIBLE_CHAR

ARRAY [length] OF VISIBLE_CHAR VISIBLE_STRING $length$

There is no 0h necessary to terminate the string.

9.1.6.3 Unicode String

The data type UNICODE_STRING $length$ is defined below; $length$ is the length of the unicode string.

ARRAY [length] OF UNSIGNED16 UNICODE_STRING $length$

9.1.6.4 Time of Day

The data type TIME_OF_DAY represents absolute time. It follows from the definition and the encoding rules that TIME_OF_DAY is represented as bit sequence of length 48.

Component ms is the time in milliseconds after midnight. Component days is the number of days since January 1, 1984.

STRUCT OF

```

    UNSIGNED28  ms,
    VOID4       reserved,
    UNSIGNED16  days
  
```

TIME_OF_DAY

9.1.6.5 Time Difference

The data type TIME_DIFFERENCE represents a time difference. It follows from the definition and the encoding rules that TIME_DIFFERENCE is represented as bit sequence of length 48.

Time differences are sums of numbers of days and milliseconds. Component ms is the number milliseconds. Component days is the number of days.

STRUCT OF

```

    UNSIGNED28  ms,
    VOID4       reserved,
    UNSIGNED16  days
  
```

TIME_DIFFERENCE

9.1.6.6 Domain

Domains can be used to transfer an arbitrary large block of data from a client to a server and vv. The contents of a data block is application specific and does not fall within the scope of this document.

9.2 Communication Objects

The communication objects are described by the services and protocols.

All services are described in a tabular form that contains the parameters of each service primitive that is defined for that service. The primitives that are defined for a particular service determine the service type (e.g. unconfirmed, confirmed, etc.). How to interpret the tabular form and what service types exist is defined in 6.3 (Communication Model).

All services assume that no failures occur in the Data Link and Physical Layer of the CAN network. These failures are resolved by the application and fall not in the scope of this document.

9.2.1 Process Data Object (PDO)

The real-time data transfer is performed by means of "Process Data Objects (PDO)". The transfer of PDOs is performed with no protocol overhead.

The PDOs correspond to entries in the device Object Dictionary and provide the interface to the application objects. Data type and mapping of application objects into a PDO is determined by a corresponding default PDO mapping structure within the Device Object Dictionary. If variable PDO-mapping is supported the number of PDOs and the mapping of application objects into a PDO may be transmitted to a device during the device configuration process (see Initialisation Procedure) by applying the SDO services to the corresponding entries of the Object Dictionary.

Number and length of PDOs of a device is application specific and have to be specified within the device profile.

There are two kinds of use for PDOs. The first is data transmission and the second data reception. It is distinguished in Transmit-PDOs (TPDOs) and Receive-PDOs (RPDOs). Devices supporting TPDOs are PDO producer and devices which are able to receive PDOs are called PDO consumer. PDOs are described by the PDO communication parameter (20h) and the PDO mapping parameter (21h). The structure of these data types are explained in 9.5.4. The PDO communication parameter describes the communication capabilities of the PDO. The PDO mapping parameter contains information about the contents of the PDOs (device variables). The indices of the corresponding Object Dictionary entries are computed by the following formulas:

- RPDO communication parameter index = 1400h + RPDO-number -1
- TPDO communication parameter index = 1800h + TPDO-number -1
- RPDO mapping parameter index = 1600h + RPDO-number -1

- TPDO mapping parameter index = 1A00h + TPDO-number -1

For each PDO the pair of communication and mapping parameter is mandatory. The entries mentioned above are described in 9.5 (Object Dictionary).

9.2.1.1 Transmission Modes

The following PDO transmission modes are distinguished:

- Synchronous Transmission
- Asynchronous Transmission

In order to synchronise devices a synchronisation object (SYNC object) is transmitted periodically by a synchronisation application. The SYNC object is represented by a pre-defined communication object (see 9.2.3). In Figure 13 the principle of synchronous and asynchronous transmission is shown. Synchronous PDOs are transmitted within a pre-defined time-window immediately after the SYNC object. The principle of synchronous transmission is described in more detail in 9.3.

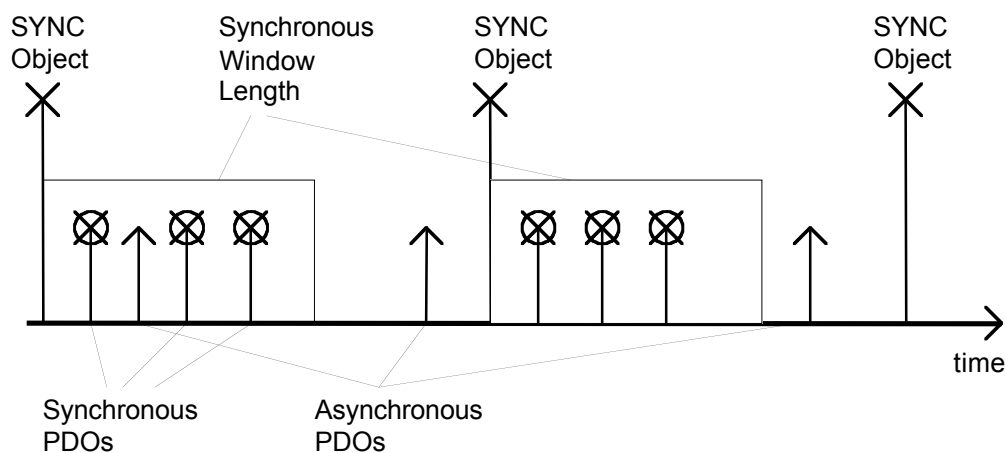

Figure 13: Synchronous and Asynchronous Transmission

The transmission type parameter of a PDO specifies the transmission mode as well as the triggering mode.

For synchronous TPDOs the transmission type also specifies the transmission rate in form of a factor based on the basic SYNC-object transmission period. A transmission type of 0 means that the message shall be transmitted after occurrence of the SYNC but acyclic (not periodically), only if an event occurred before the SYNC. A transmission type of 1 means that the message is transmitted with every SYNC object. A transmission type of n means that the message is transmitted with every n-th SYNC object. Asynchronous TPDOs are transmitted without any relation to a SYNC.

The data of synchronous RPDOs received after the occurrence of a SYNC is passed to the application with the occurrence of the following SYNC, independent of the transmission rate specified by the transmission type. The data of asynchronous RPDOs is passed directly to the application.

9.2.1.2 Triggering Modes

Three message triggering modes are distinguished:

- **Event Driven**

Message transmission is triggered by the occurrence of an object specific event. For synchronous PDOs this is the expiration of the specified transmission period, synchronised by the reception of the SYNC object.

For acyclically transmitted synchronous PDOs and asynchronous PDOs the triggering of a message transmission is a device-specific event specified in the device profile.

- **Timer Driven**

Message transmission is either triggered by the occurrence of a device-specific event or if a specified time has elapsed without occurrence of an event.

- **Remotely requested**

The transmission of an asynchronous PDO is initiated on receipt of a remote request initiated by any other device (PDO consumer).

9.2.1.3 PDO Services

PDO transmission follows the producer/consumer relationship as described in 6.3.3.

Attributes:

- PDO number: PDO number [1..512] for every user type on the local device
- user type: one of the values {consumer, producer}
- data type: according to the PDO mapping
- inhibit-time: $n * 100 \mu s$, $n \geq 0$

9.2.1.3.1 Write PDO

For the Write PDO service the push model is valid. There are zero or more consumers of a PDO. A PDO has exactly one producer.

Through this service the producer of a PDO sends the data of the mapped application objects to the consumer(s).

Table 3: Write PDO

<i>Parameter</i>	<i>Request / Indication</i>
Argument PDO Number Data	Mandatory mandatory mandatory

9.2.1.3.2 Read PDO

For the Read PDO service the pull model is valid. There are one or more consumers of a PDO. A PDO has exactly one producer.

Through this service the consumer of a PDO requests the producer to supply the data of the mapped application objects. The service is confirmed. The remote result parameter will confirm the value.

Table 4: Read PDO

<i>Parameter</i>	<i>Request / Indication</i>	<i>Response / Confirm</i>
Argument PDO Number	Mandatory mandatory	
Remote Result Data		Mandatory mandatory

9.2.1.4 PDO Protocol

9.2.1.4.1 Write PDO Protocol

The service for a PDO write request is unconfirmed. The PDO producer sends the process data within a PDO to the network. There can be 0..n PDO consumers. At the PDO consumer(s) the reception of a valid PDO is indicated. Figure 14 shows the Write PDO Protocol.

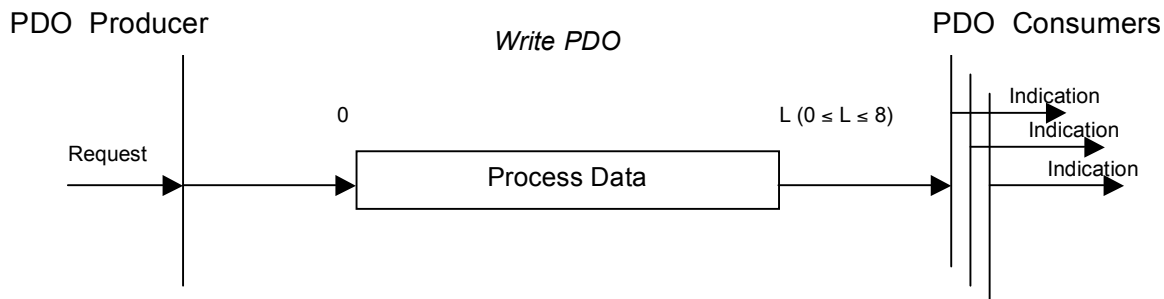

Figure 14: Write PDO Protocol

Process-Data: up to L bytes of application data according to the PDO mapping

If L exceeds the number of bytes 'n' defined by the actual PDO mapping length only the first 'n' bytes are used by the consumer. If L is less than 'n' the data of the received PDO is not processed and an Emergency message with error code 8210h has to be produced if Emergency is supported.

9.2.1.4.2 Read PDO Protocol

The service for a PDO read request is confirmed. One or more PDO consumer transmit a remote transmission request frame (RTR) to the network. At the reception of the RTR frame the PDO producer for the requested PDO transmits the PDO. At all PDO consumers for this PDO the reception is indicated. There can be 0..n PDO consumers. The read service is optional and depends on the hardware capabilities. Figure 15 shows the Read PDO Protocol.

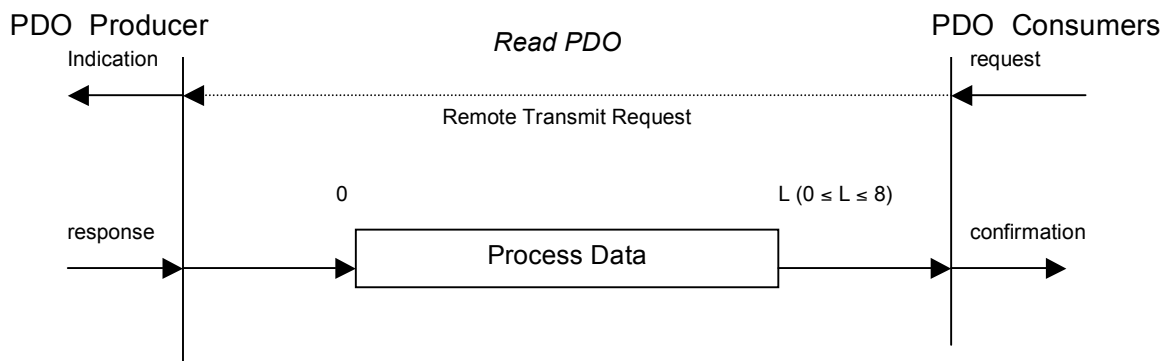

Figure 15: Read PDO Protocol

Process-Data: up to L bytes of application data according to the PDO mapping

If L exceeds the number of bytes 'n' defined by the actual PDO mapping length only the first 'n' bytes are used by the consumer. If L is less than 'n' the data of the received PDO is not processed and an Emergency message with error code 8210h has to be produced if Emergency is supported.

9.2.2 Service Data Object (SDO)

With Service Data Objects (SDOs) the access to entries of a device Object Dictionary is provided. As these entries may contain data of arbitrary size and data type SDOs can be used to transfer multiple *data sets* (each containing an arbitrary large block of data) from a client to a server and vice versa. The client can control via a *multiplexor* (index and sub-index of the Object Dictionary) which data set is to be transferred. The contents of the data set are defined within the Object Dictionary.

Basically a SDO is transferred as a sequence of *segments*. Prior to transferring the segments there is an initialisation phase where client and server prepare themselves for transferring the segments. For SDOs, it is also possible to transfer a data set of up to four bytes during the initialisation phase. This mechanism is called an *expedited* transfer.

Optionally a SDO can be transferred as a sequence of *blocks* where each block is a sequence of up to 127 segments containing a sequence number and the data. Prior to transferring the blocks there is an initialisation phase where client and server can prepare themselves for transferring the blocks and negotiating the number of segments in one block. After transferring the blocks there is a finalisation phase where client and server can optionally verify the correctness of the previous data transfer by comparing checksums derived from the data set. This transfer type mentioned above is called a *block* transfer which is faster than the segmented transfer for a large set of data.

In SDO Block Upload it is possible that the size of the data set does not justify the use of a block transfer because of the implied protocol overhead. In these cases a support for a fallback to the segmented or expedited transfer in initialisation phase can be implemented. As the assumption of the minimal data set size for which a block transfer outperforms the other transfer types depends on various parameters the client indicates this threshold value in bytes to the server in initialisation phase. For the block transfer a Go-Back-n ARQ (Automatic Repeat Request) scheme is used to confirm each block.

After block download the server indicates the client the last successfully received segment of this block transfer by acknowledging this segment sequence number. Doing this the server implicitly acknowledges all segments preceding this segment. The client has to start the following block transfer with the retransmission of all not acknowledged data. Additionally the server has to indicate the number of segments per block for the next block transfer.

After block upload the client indicates the server the last successfully received segment of this block transfer by acknowledging this segment sequence number. Doing this the client implicitly acknowledges all segments preceding this segment. The server has to start the following block transfer with the retransmission of all not acknowledged data. Additionally the client has to indicate the number of segments per block for the next block transfer.

For all transfer types it is the client that takes the initiative for a transfer. The owner of the accessed Object Dictionary is the server of the SDO. Both the client or the server can take the initiative to abort the transfer of a SDO.

By means of a SDO a peer-to-peer communication channel between two devices is established. A device may support more than one SDO. One supported Server-SDO (SSDO) is the default case (Default SDO).

SDOs are described by the SDO communication parameter record (22h). The structure of this data type is explained in 9.5.4. The SDO communication parameter describes the communication capabilities of the Server-SDOs and Client-SDOs (CSDO). The indices of the corresponding Object Dictionary entries are computed by the following formulas:

- SSDO communication parameter index = 1200h + SSDO-number -1
- CSDO communication parameter index = 1280h + CSDO-number -1

For each SDO the communication parameters are mandatory. If only one SSDO exists the communication parameters can be omitted. The entries mentioned above are described in 9.5 (Object Dictionary).

9.2.2.1 SDO Services

The model for the SDO communication is the Client/Server model as described in 0.

Attributes:

- SDO number: SDO number [1..128] for every user type on the local device
- user type: one of the values {client, server}
- mux data type multiplexor containing index and sub-index of type
STRUCTURE OF UNSIGNED (16) , UNSIGNED (8) ,
with index specifying an entry of the device Object

Dictionary and "sub-index" specifying a component of a device object dictionary entry

- transfer type: depends on the length of data to transfer:
 - expedited for up to 4 data bytes
 - segmented or block for more than 4 data bytes
- data type: according to the referenced index and sub-index

The following services can be applied onto a SDO depending on the application requirements:

- SDO Download, which can be split up into
 - Initiate SDO Download
 - Download SDO Segment
- SDO Upload, which can be split up into
 - Initiate SDO Upload
 - Upload SDO Segment
- Abort SDO Transfer

When using the segmented SDO download and upload services, the communication software will be responsible for transferring the SDO as a sequence of segments.

Expedited transfer has to be supported. Segmented transfer has to be supported if objects larger than 4 Bytes are supported. Optionally the following SDO services for doing a block transfer with higher bus utilisation and performance for a large data set size can be implemented:

- SDO Block Download, which can be split up into
 - Initiate Block Download
 - Download Block
 - End Block Download
- SDO Block Upload, which can be split up into
 - Initiate Block Upload
 - Upload Block
 - End Block Upload

When using the SDO block download and upload services, the communication software will be responsible for transferring the data as a sequence of blocks.

In SDO Block Upload Protocol a support for a switch to SDO Upload Protocol in 'Initiate SDO Block Upload' can be implemented to increase transfer performance for data which size does not justifies using the protocol overhead of the 'SDO Block Upload' protocol.

For aborting a SDO block transfer the Abort SDO Transfer Service is used.

9.2.2.1.1 SDO Download

Through this service the client of a SDO downloads data to the server (owner of the Object Dictionary). The data, the multiplexor (index and sub-index) of the data set that has been downloaded and its size (only optionally for segmented transfer) are indicated to the server.

The service is confirmed. The remote result parameter will indicate the success or failure of the request. In case of a failure, optionally the reason is confirmed.

The SDO download consists of at least the Initiate SDO Download service and optional of Download SDO Segment services (data length > 4 bytes).

Table 5: SDO Download

<i>Parameter</i>	<i>Request / Indication</i>	<i>Response / Confirm</i>
Argument SDO Number Data Size Multiplexor	Mandatory mandatory mandatory optional mandatory	Mandatory selection selection optional
Remote Result Success Failure Reason		

9.2.2.1.2 Initiate SDO Download

Through this service the client of SDO requests the server to prepare for downloading data to the server. Optionally the size of the data to be downloaded is indicated to the server. The multiplexor of the data set whose download is initiated and the transfer type are indicated to the server. In case of an expedited download, the data of the data set identified by the multiplexor and size is indicated to the server.

Table 6: Initiate SDO Download

<i>Parameter</i>	<i>Request / Indication</i>	<i>Response / Confirm</i>
Argument SDO Number Size Multiplexor Transfer type Normal Expedited Data	Mandatory mandatory optional mandatory mandatory selection selection mandatory	
Remote Result Success		Mandatory mandatory

The service is confirmed. The remote result parameter will indicate the success of the request. In case of a failure, an Abort SDO Transfer request has to be executed. In the case of a successful expedited download of a multiplexed DOMAIN, this service concludes the download of the data set identified by multiplexor.

9.2.2.1.3 Download SDO Segment

Through this service the client of a SDO supplies the data of the next segment to the server. The segment data and optionally its size are indicated to the server. The continue parameter indicates the server whether there are still more segments to be downloaded or that this was the last segment to be downloaded.

Table 7: Download SDO Segment

<i>Parameter</i>	<i>Request / Indication</i>	<i>Response / Confirm</i>
Argument SDO number Data Size Continue More Last	Mandatory mandatory mandatory optional mandatory selection selection	
Remote Result Success		Mandatory mandatory

The service is confirmed. The remote result parameter will indicate the success of the request. In case of a failure, an Abort SDO transfer request must be executed. In case of success, the server has accepted the segment data and is ready to accept the next segment. There can be at most one Download SDO Segment service outstanding for a SDO transfer.

A successful Initiate SDO Download service with segmented transfer type must have been executed prior to this service.

9.2.2.1.4 SDO Upload

Through this service the client of a SDO uploads data from the server. The multiplexor (index and sub-index) of the data set that has to be uploaded is indicated to the server.

The SDO upload consists of at least the Initiate SDO Upload service and optional of Upload SDO Segment services (data length > 4 bytes).

Table 8: SDO Upload

<i>Parameter</i>	<i>Request / Indication</i>	<i>Response / Confirm</i>
Argument SDO number Multiplexor	Mandatory mandatory mandatory	
Remote Result Success Data Size Failure Reason		Mandatory selection mandatory optional selection optional

The service is confirmed. The remote result parameter will indicate the success or failure of the request. In case of a failure, optionally the reason is confirmed. In case of success, the data and its size (optionally for segmented transfer) are confirmed.

9.2.2.1.5 Initiate SDO Upload

Through this service the client of a SDO requests the server to prepare for uploading data to the client. The multiplexor (index and sub-index) of the data set whose upload is initiated is indicated to the server.

The service is confirmed. The remote result parameter will indicate the success of the request. In case of a failure, an Abort SDO Transfer request has to be executed. In the case of success, the size (optionally for segmented transfer) of the data to be uploaded is confirmed. In case of successful expedited upload, this service concludes the upload of the data set identified by multiplexor and the corresponding data is confirmed.

Table 9: Initiate SDO Upload

<i>Parameter</i>	<i>Request / Indication</i>	<i>Response / Confirm</i>
Argument SDO number Multiplexor	Mandatory mandatory mandatory	
Remote Result Success Size Multiplexor Transfer type Normal Expedited Data		Mandatory mandatory optional mandatory mandatory selection selection mandatory

9.2.2.1.6 Upload SDO Segment

Through this service the client of a SDO requests the server to supply the data of the next segment. The continue parameter indicates the client whether there are still more segments to be uploaded or that this was the last segment to be uploaded. There can be at most one Upload SDO Segment service outstanding for a SDO.

The service is confirmed. The remote result parameter will indicate the success of the request. In case of a failure, an Abort SDO Transfer request must be executed. In case of success, the segment data and optionally its size are confirmed.

A successful Initiate SDO Upload service with segmented transfer type must have been executed prior to this service.

Table 10: Upload SDO Segment

<i>Parameter</i>	<i>Request / Indication</i>	<i>Response / Confirm</i>
Argument SDO number	Mandatory mandatory	
Remote Result Success Data Size Continue More Last		Mandatory mandatory mandatory optional mandatory selection selection

9.2.2.1.7 Abort SDO Transfer

This service aborts the up- or download of a SDO referenced by its number. Optionally the reason is indicated. The service is unconfirmed. The service may be executed at any time by both the client and the server of a SDO. If the client of a SDO has a confirmed service outstanding, the indication of the abort is taken to be the confirmation of that service.

Table 11: Abort SDO Transfer

<i>Parameter</i>	<i>Request / Indication</i>
Argument SDO number Multiplexor Reason	Mandatory mandatory mandatory mandatory

9.2.2.1.8 SDO Block Download

Through this service the client of SDO downloads data to the server of SDO (owner of the Object Dictionary) using the block download protocol. The data, the multiplexor (index and sub-index) of the data set that has been downloaded and optionally its size are indicated to the server. The service is confirmed. The remote result parameter will indicate the success or failure of the request. In case of a failure, optionally the reason is confirmed.

Table 12: SDO Block Download

<i>Parameter</i>	<i>Request / Indication</i>	<i>Response / Confirm</i>
Argument SDO Number Data Size Multiplexor	Mandatory mandatory mandatory optional mandatory	
Remote Result Success Failure Reason		Mandatory selection selection optional

9.2.2.1.9 Initiate SDO Block Download

Through this service the client of SDO requests the server of SDO (owner of the Object Dictionary) to prepare for downloading data to the server.

The multiplexor of the data set whose download is initiated and optionally the size of the downloaded data in bytes are indicated to the server.

The client as well as the server indicating their ability and/or demand to verify the complete transfer with a checksum in End SDO Block Download.

Table 13: Initiate SDO Block Download

<i>Parameter</i>	<i>Request / Indication</i>	<i>Response / Confirm</i>
Argument SDO Number Size CRC ability yes no Multiplexor	Mandatory mandatory optional mandatory selection selection mandatory	
Remote Result Success CRC ability yes no Blksize		Mandatory mandatory mandatory selection selection mandatory

The service is confirmed. The Remote Result parameter will indicate the success of the request, the number of segments per block the server of SDO is able to receive and its ability and/or demand to verify the complete transfer with a checksum. In case of a failure, an Abort SDO Transfer request must be executed.

9.2.2.1.10 Download SDO Block

By this service the client of SDO supplies the data of the next block to the server of SDO. The block data is indicated to the server by a sequence of segments. Each segment consists of the data and a sequence number starting with 1 which is increased for each segment by 1 up to *blksize*. The parameter *blksize* is negotiated between server and client in the 'Initiate Block Download' protocol and can be changed by the server with each confirmation for a block transfer. The continue parameter

indicates the server whether to stay in the 'Download Block' phase or to change in the 'End Download Block' phase.

Table 14: Download SDO Block

<i>Parameter</i>	<i>Request / Indication</i>	<i>Response / Confirm</i>
Argument SDO Number Data Continue More Last	Mandatory mandatory mandatory mandatory selection selection	
Remote Result Success Ackseq Blksize		Mandatory mandatory mandatory mandatory

The service is confirmed. The Remote Result parameter will indicate the success of the request. In case of a success the ackseq parameter indicates the sequence number of the last segment the server has received successfully. If this number does not correspond with the sequence number of the last segment sent by the client during this block transfer the client has to retransmit all segments discarded by the server with the next block transfer. In case of a fatal failure, an Abort SDO Transfer request must be executed. In case of success, the server has accepted all acknowledged segment data and is ready to accept the next block. There can be at most one Download SDO Block service outstanding for a SDO transfer.

A successful 'Initiate SDO Block Download' service must have been executed prior to this service.

9.2.2.1.11 End SDO Block Download

Through this service the SDO Block Download is concluded.

The number of bytes not containing valid data in the last transmitted segments is indicated to the server.

If the server as well as the client have indicated their ability and demand to check the complete transfer with a checksum in 'Initiate SDO Block Download' this checksum is indicated to the server by the client. The server also has to generate a checksum which has to be compared with the one generated by the client.

Table 15: End SDO Block Download

<i>Parameter</i>	<i>Request / Indication</i>	<i>Response / Confirm</i>
Argument SDO Number Valid_data Cchecksum	Mandatory mandatory mandatory mandatory if negotiated in initiate	
Remote Result Success		Mandatory mandatory

The service is confirmed. The Remote Result parameter will indicate the success of the request (matching checksums between client and server if negotiated) and concludes the download of the data set. In case of a failure, an Abort SDO Transfer request must be executed.

9.2.2.1.12 SDO Block Upload

Through this service the client of SDO uploads data from the server of SDO (owner of the Object Dictionary) using the SDO block upload protocol. The data, the multiplexor (index and sub-index) of the data set that has to be uploaded and optionally its size are indicated to the server.

The service is confirmed. The Remote Result parameter will indicate the success or failure of the request. In case of a failure, optionally the reason is confirmed. In case of a success, the data and optionally its size is confirmed.

Table 16: SDO Block Upload

<i>Parameter</i>	<i>Request / Indication</i>	<i>Response / Confirm</i>
Argument SDO Number Multiplexor Remote Result Success Data Size Failure Reason	Mandatory mandatory mandatory	Mandatory selection mandatory optional selection optional

9.2.2.1.13 Initiate SDO Block Upload

Through this service the client of SDO requests the server of SDO (owner of the Object Dictionary) to prepare for uploading data to the client.

The multiplexor of the data set whose upload is initiated and the number of segments the client of the SDO is able to receive are indicated to the server.

A protocol switch threshold value is indicated to the server. If the number of bytes that has to be uploaded is less or equal this value the server can optionally conclude this data transfer with the 'SDO Upload Protocol' as described in 9.2.2.1.4.

The client as well as the server indicating their ability and/or demand to verify the complete transfer with a checksum in End SDO Block Upload

Optionally the size of the uploaded data in bytes are indicated to the client.

Table 17: Initiate SDO Block Upload

<i>Parameter</i>	<i>Request / Indication</i>	<i>Response / Confirm</i>
Argument SDO Number Blksize CRC ability Yes No Multiplexor Threshold Remote Result Success CRC ability Yes No Size	Mandatory mandatory mandatory mandatory selection selection mandatory mandatory	Mandatory mandatory mandatory selection selection optional

The service is confirmed. In case of a failure, an Abort SDO Transfer request must be executed. In case of success the size of the data in bytes to be uploaded is optionally indicated to the client.

If the size of the data that has to be uploaded is less or equal threshold the server can continue with the SDO block upload protocol. In this case the Remote Result parameter and the further protocol is described in 9.2.2.2.14.

9.2.2.1.14 Upload SDO Block

Through this service the client of SDO uploads the data of the next block from the server of SDO. The block data is indicated to the client by a sequence of segments. Each segment consists of the segment data and a sequence number starting with 1 which is increased for each segment by 1 up to blksize. The parameter blksize is negotiated between server and client in the 'Initiate Block Upload' protocol and can be changed by the client with each confirmation for a block transfer. The continue parameter indicates the client whether to stay in the 'Upload Block' phase or to change in the 'End Upload Block' phase.

Table 18: Upload SDO Block

<i>Parameter</i>	<i>Request / Indication</i>	<i>Response / Confirm</i>
Argument SDO Number Data Continue More Last	Mandatory mandatory mandatory mandatory selection selection	
Remote Result Success Ackseq Blksize		Mandatory mandatory mandatory mandatory

The service is confirmed. The Remote Result parameter will indicate the success of the request. In case of a success the ackseq parameter indicates the sequence number of the last segment the client has received successfully. If this number does not correspond with the sequence number of the last segment sent by the server during this block transfer the server has to retransmit all segments discarded by the client with the next block transfer. In case of a fatal failure, an Abort SDO Transfer request must be executed. In case of success, the client has accepted all acknowledged segment data and is ready to accept the next block. There can be at most one Upload Block service outstanding for a SDO transfer.

A successful 'Initiate SDO Block Upload' service must have been executed prior to this service.

9.2.2.1.15 End SDO Block Upload

Through this service the SDO Block Upload is concluded.

The number of bytes not containing valid data in the last transmitted segments is indicated to the client.

If the server as well as the client have indicated their ability and demand to check the complete transfer with a checksum during 'Initiate SDO Block Upload' this checksum is indicated to the client by the server. The client also has to generate a checksum which has to be compared with the one generated by the server.

Table 19: End SDO Block Upload

<i>Parameter</i>	<i>Request / Indication</i>	<i>Response / Confirm</i>
Argument SDO Number Valid_data Checksum	Mandatory mandatory mandatory mandatory if negotiated in initiate	
Remote Result Success		Mandatory mandatory

The service is confirmed. The Remote Result parameter will indicate the success of the request (matching checksums between client and server if demanded) and concludes the download of the data set. In case of a failure, an Abort SDO Transfer request must be executed.

9.2.2.2 SDO Protocols

Six confirmed services (SDO Download, SDO Upload, Initiate SDO Upload, Initiate SDO Download, Download SDO Segment, and Upload SDO Segment) and one unconfirmed service (Abort SDO Transfer) are defined for Service Data Objects doing the standard segmented/expedited transfer. Eight confirmed services (SDO Block Download, SDO Block Upload, Initiate SDO Upload, Initiate SDO Block Download, Download SDO Segment, Upload SDO Segment, End SDO Upload and End SDO Block Download) and one unconfirmed service (Abort SDO Block Transfer) are defined for Service Data Objects doing the optional block transfer.

9.2.2.2.1 Download SDO Protocol

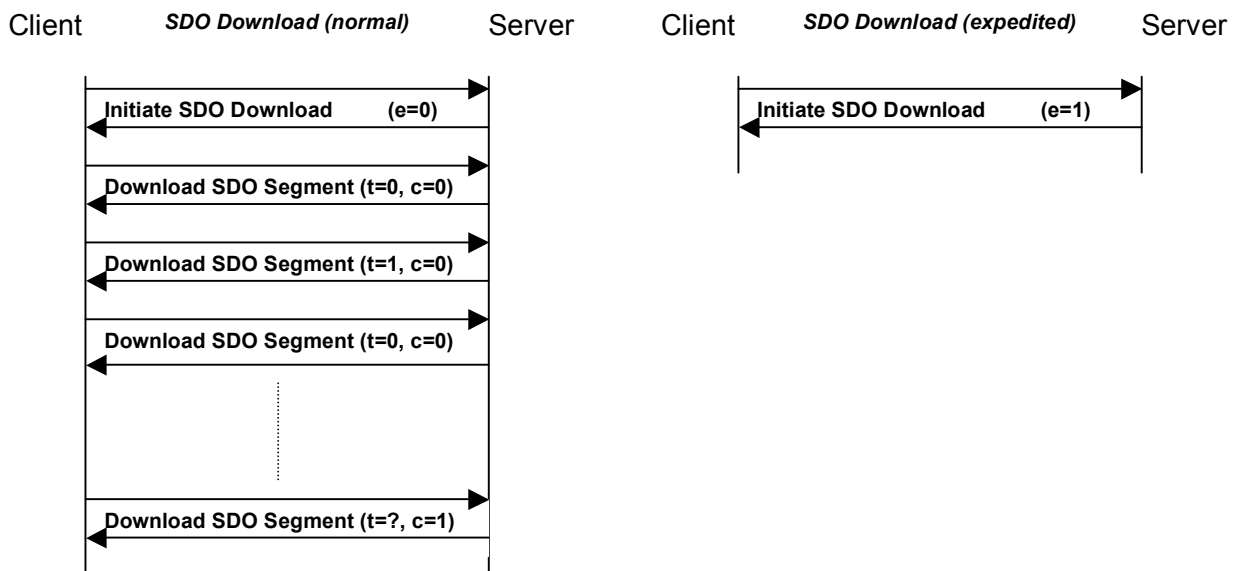

Figure 16: Download SDO Protocol

This protocol is used to implement the SDO Download service. SDOs are downloaded as a sequence of zero or more Download SDO Segment services preceded by an Initiate SDO Download service. The sequence is terminated by:

- an Initiate SDO Download request/indication with the e-bit set to 1 followed by an Initiate SDO Download response/confirm, indicating the successful completion of an expedited download sequence.
- a Download SDO Segment response/confirm with the c-bit set to 1, indicating the successful completion of a normal download sequence.
- an Abort SDO Transfer request/indication, indicating the unsuccessful completion of the download sequence.
- a new Initiate Domain Download request/indication, indicating the unsuccessful completion of the download sequence and the start of a new download sequence.

If in the download of two consecutive segments the toggle bit does not alter, the contents of the last segment has to be ignored. If such an error is reported to the application, the application may decide to abort the download.

9.2.2.2.2 Initiate SDO Download Protocol

This protocol is used to implement the Initiate SDO Download service for SDOs.

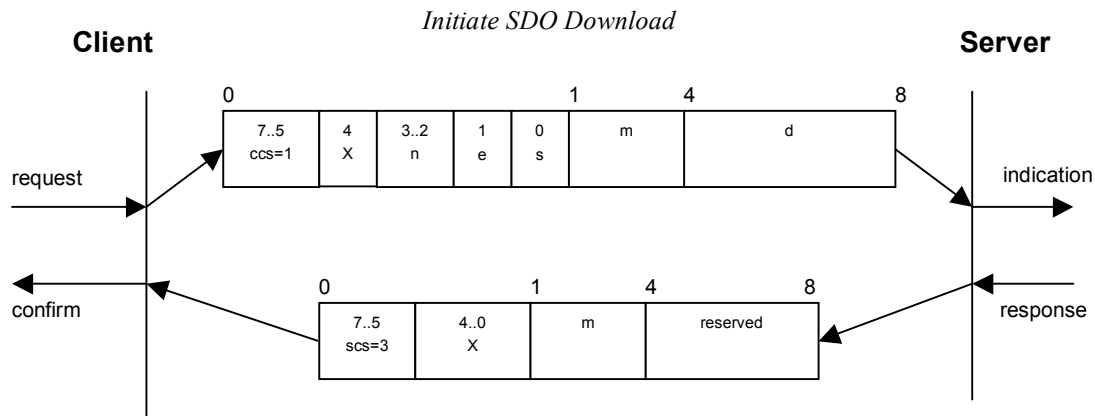

Figure 17: Initiate SDO Download Protocol

- **ccs:** client command specifier
 - 1: initiate download request
- **scs:** server command specifier
 - 3: initiate download response
- **n:** Only valid if *e* = 1 and *s* = 1, otherwise 0. If valid it indicates the number of bytes in *d* that do not contain data. Bytes [8-*n*, 7] do not contain data.
- **e:** transfer type
 - 0: normal transfer
 - 1: expedited transfer
- **s:** size indicator
 - 0: data set size is not indicated
 - 1: data set size is indicated
- **m:** multiplexor. It represents the index/sub-index of the data to be transfer by the SDO.
- **d:** data
 - e* = 0, *s* = 0: *d* is reserved for further use.
 - e* = 0, *s* = 1: *d* contains the number of bytes to be downloaded.
 - Byte 4 contains the lsb and byte 7 contains the msb.
 - e* = 1, *s* = 1: *d* contains the data of length 4-*n* to be downloaded, the encoding depends on the type of the data referenced by index and sub-index
 - e* = 1, *s* = 0: *d* contains unspecified number of bytes to be downloaded
- **X:** not used, always 0
- **reserved:** reserved for further use, always 0

9.2.2.2.3 Download SDO Segment Protocol

This protocol is used to implement the Download SDO Segment service.

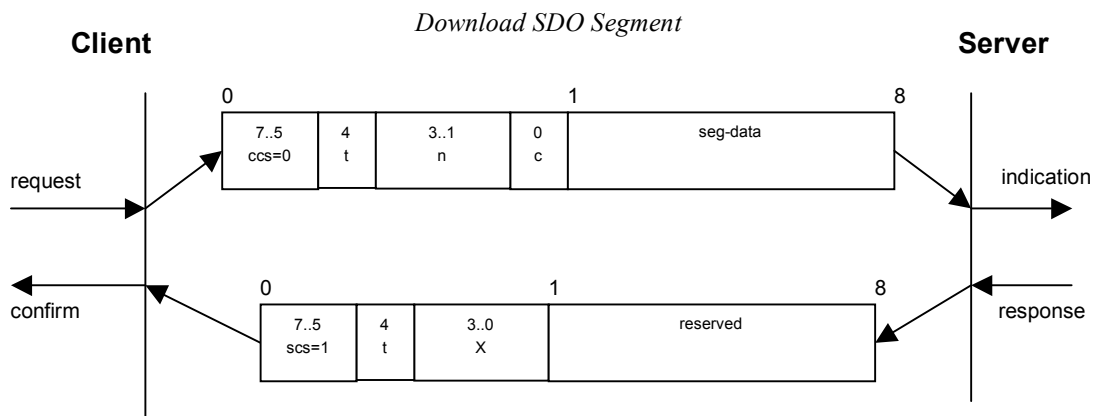

Figure 18: Download SDO Segment Protocol

- **ccs**: client command specifier
0: download segment request
- **scs**: server command specifier
1: download segment response
- **seg-data**: at most 7 bytes of segment data to be downloaded. The encoding depends on the type of the data referenced by index and sub-index
- **n**: indicates the number of bytes in seg-data that do not contain segment data. Bytes [8-n, 7] do not contain segment data. n = 0 if no segment size is indicated.
- **c**: indicates whether there are still more segments to be downloaded.
0 more segments to be downloaded
1: no more segments to be downloaded
- **t**: toggle bit. This bit must alternate for each subsequent segment that is downloaded. The first segment will have the toggle-bit set to 0. The toggle bit will be equal for the request and the response message.
- **X**: not used, always 0
- **reserved**: reserved for further use, always 0

9.2.2.2.4 Upload SDO Protocol

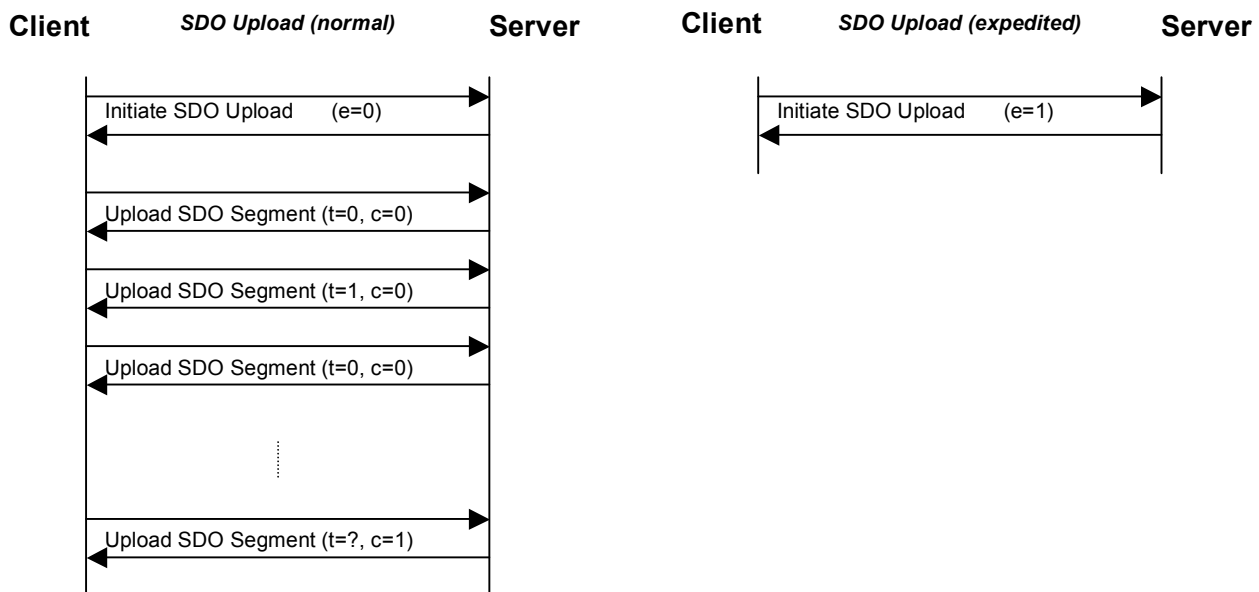

Figure 19: Upload SDO Protocol

This protocol is used to implement the SDO Upload service. SDO are uploaded as a sequence of zero or more Upload SDO Segment services preceded by an Initiate SDO Upload service. The sequence is terminated by:

- an Initiate SDO Upload response/confirm with the e-bit set to 1, indicating the successful completion of an expedited upload sequence.
- an Upload SDO Segment response/confirm with the c-bit set to 1, indicating the successful completion of a normal upload sequence.
- an Abort SDO Transfer request/indication, indicating the unsuccessful completion of the upload sequence.
- a new Initiate SDO Upload request/indication, indicating the unsuccessful completion of the upload sequence and the start of a new sequence.

If in the upload of two consecutive segments the toggle bit does not alter, the contents of the last segment has to be ignored. If such an error is reported to the application, the application may decide to abort the upload.

9.2.2.2.5 Initiate SDO Upload Protocol

This protocol is used to implement the Initiate SDO Upload service.

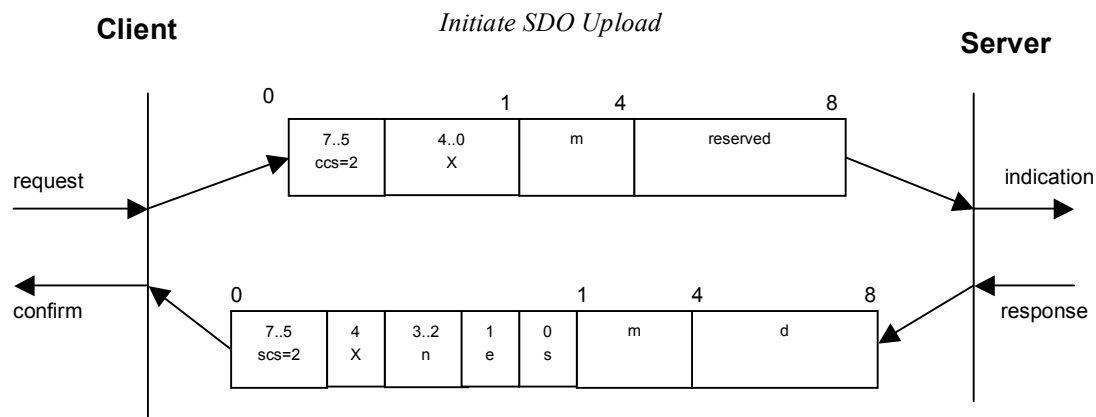

Figure 20: Initiate SDO Upload Protocol

- **ccs**: client command specifier
2: initiate upload request
- **scs**: server command specifier
2: initiate upload response
- **n**: Only valid if $e = 1$ and $s = 1$, otherwise 0. If valid it indicates the number of bytes in d that do not contain data. Bytes $[8-n, 7]$ do not contain segment data.
- **e**: transfer type
0: normal transfer
1: expedited transfer
- **s**: size indicator
0: data set size is not indicated
1: data set size is indicated
- **m**: multiplexor. It represents the index/sub-index of the data to be transfer by the SDO.
- **d**: data
 - $e = 0, s = 0$: d is reserved for further use.
 - $e = 0, s = 1$: d contains the number of bytes to be uploaded.
Byte 4 contains the lsb and byte 7 contains the msb.
 - $e = 1, s = 1$: d contains the data of length $4-n$ to be uploaded,
the encoding depends on the type of the data referenced
by index and sub-index
 - $e = 1, s = 0$: d contains unspecified number of bytes to be uploaded.
- **X**: not used, always 0
- **reserved**: reserved for further use , always 0

9.2.2.2.6 Upload SDO Segment Protocol

This protocol is used to implement the Upload SDO Segment service.

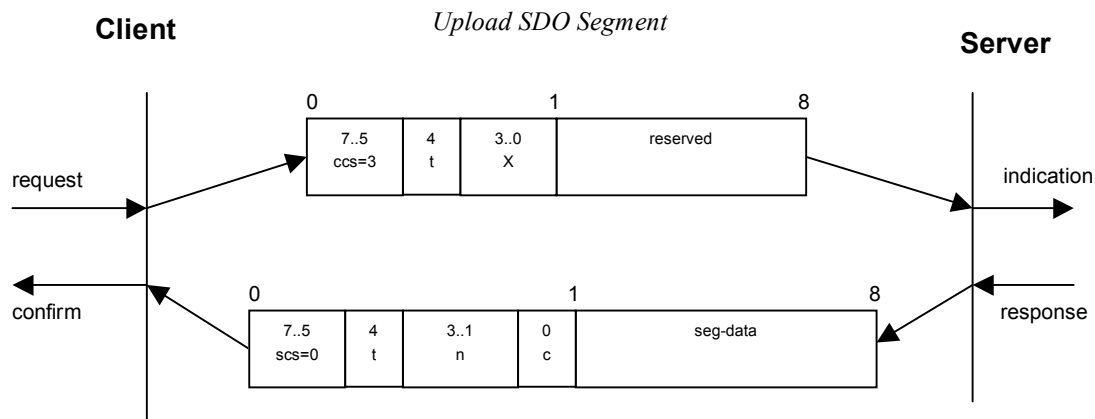

Figure 21: Upload SDO Segment Protocol

- **ccs**: client command specifier
3: upload segment request
- **scs**: server command specifier
0: upload segment response
- **t**: toggle bit. This bit must alternate for each subsequent segment that is uploaded. The first segment will have the toggle-bit set to 0. The toggle bit will be equal for the request and the response message.
- **c**: indicates whether there are still more segments to be uploaded.
0: more segments to be uploaded
1: no more segments to be uploaded
- **seg-data**: at most 7 bytes of segment data to be uploaded. The encoding depends on the type of the data referenced by index and sub-index
- **n**: indicates the number of bytes in seg-data that do not contain segment data. Bytes [8-n, 7] do not contain segment data. n = 0 if no segment size is indicated.
- **X**: not used, always 0
- **reserved**: reserved for further use, always 0

9.2.2.2.7 Abort SDO Transfer Protocol

This protocol is used to implement the Abort SDO Transfer Service.

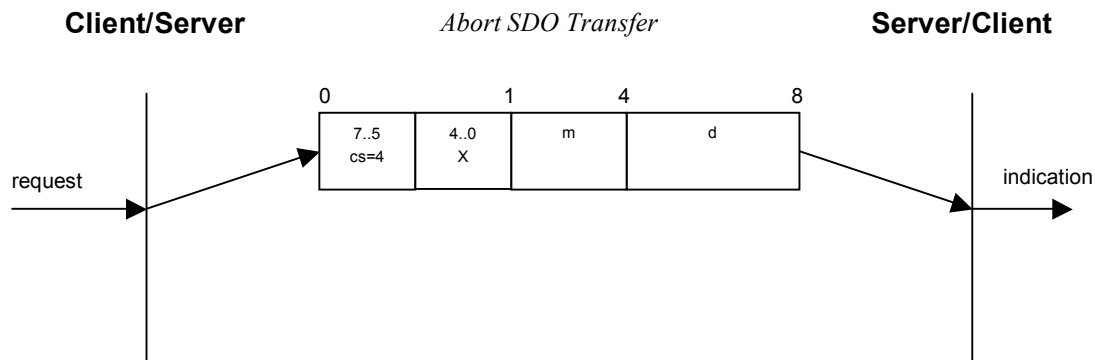

Figure 22: Abort SDO Transfer Protocol

- **cs:** command specifier
4: abort transfer request
- **X:** not used, always 0
- **m:** multiplexor. It represents index and sub-index of the SDO.
- **d:** contains a 4 byte abort code about the reason for the abort.

The abort code is encoded as UNSIGNED32 value.

Table 20: SDO abort codes

Abort code	Description
0503 0000h	Toggle bit not alternated.
0504 0000h	SDO protocol timed out.
0504 0001h	Client/server command specifier not valid or unknown.
0504 0002h	Invalid block size (block mode only).
0504 0003h	Invalid sequence number (block mode only).
0504 0004h	CRC error (block mode only).
0504 0005h	Out of memory.
0601 0000h	Unsupported access to an object.
0601 0001h	Attempt to read a write only object.
0601 0002h	Attempt to write a read only object.
0602 0000h	Object does not exist in the object dictionary.
0604 0041h	Object cannot be mapped to the PDO.
0604 0042h	The number and length of the objects to be mapped would exceed PDO length.
0604 0043h	General parameter incompatibility reason.
0604 0047h	General internal incompatibility in the device.
0606 0000h	Access failed due to an hardware error.
0607 0010h	Data type does not match, length of service parameter does not match
0607 0012h	Data type does not match, length of service parameter too high
0607 0013h	Data type does not match, length of service parameter too low
0609 0011h	Sub-index does not exist.

0609 0030h	Value range of parameter exceeded (only for write access).
0609 0031h	Value of parameter written too high.
0609 0032h	Value of parameter written too low.
0609 0036h	Maximum value is less than minimum value.
0800 0000h	general error
0800 0020h	Data cannot be transferred or stored to the application.
0800 0021h	Data cannot be transferred or stored to the application because of local control.
0800 0022h	Data cannot be transferred or stored to the application because of the present device state.
0800 0023h	Object dictionary dynamic generation fails or no object dictionary is present (e.g. object dictionary is generated from file and generation fails because of an file error).

The abort codes not listed here are reserved.

9.2.2.2.8 SDO Block Download Protocol

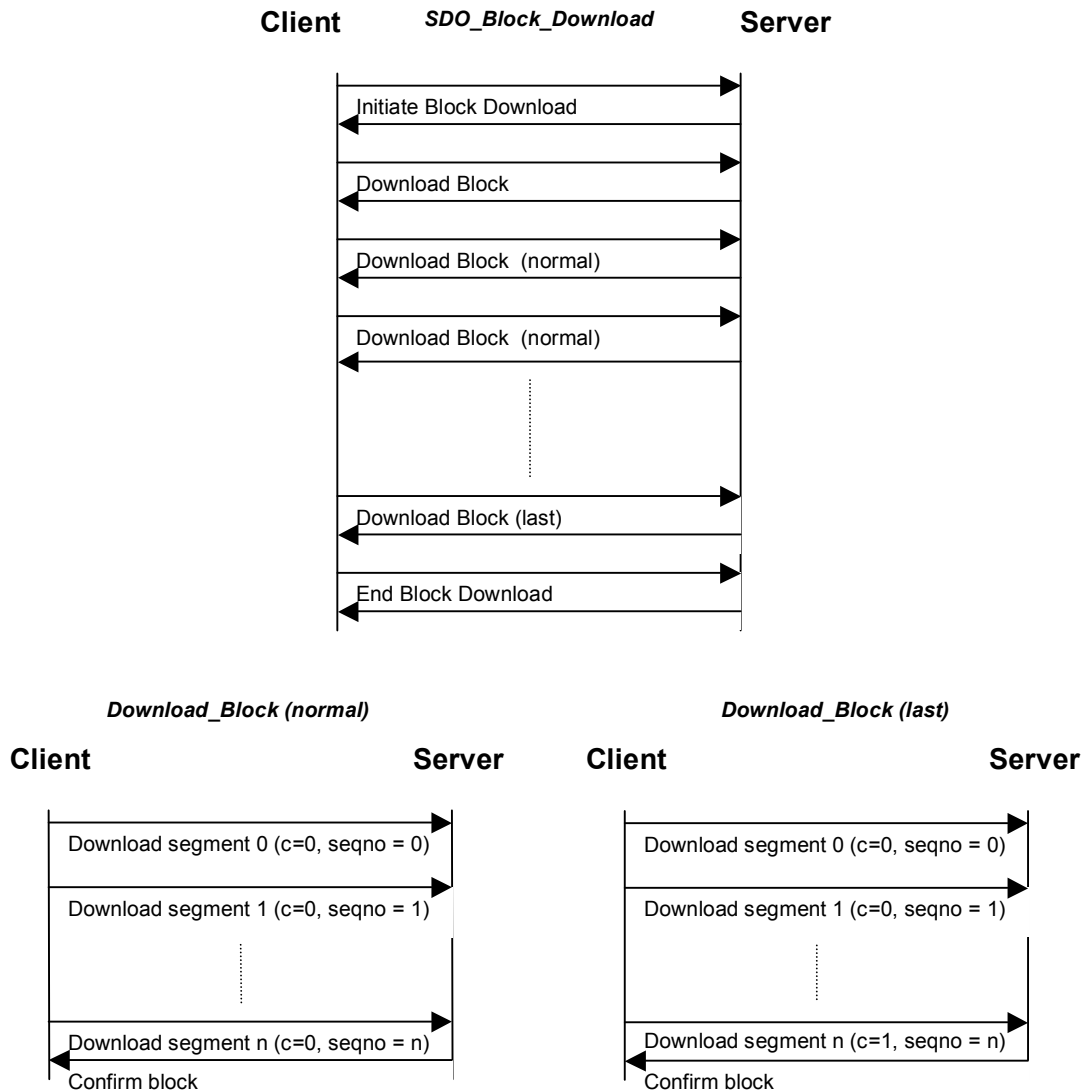

Figure 23: SDO Block Download Protocol

This protocol is used to implement a SDO Block Download service. SDOs are downloaded as a sequence of Download SDO Block services preceded by an Initiate SDO Block Download service. The SDO Download Block sequence is terminated by:

- a downloaded segment within a block with the c-bit set to 1, indicating the completion of the block download sequence.
- an 'Abort SDO Transfer' request/indication, indicating the unsuccessful completion of the download sequence.

The whole 'SDO Block Download' service is terminated with the End SDO Block Download service. If client as well as server have indicated the ability to generate a CRC during the Initiate SDO Block Download service the server has to generate the CRC on the received data. If this CRC differs from the CRC generated by the client the server has to indicate this with an 'Abort SDO Transfer' indication.

9.2.2.2.9 Initiate SDO Block Download Protocol

This protocol is used to implement the Initiate SDO Block Download service.

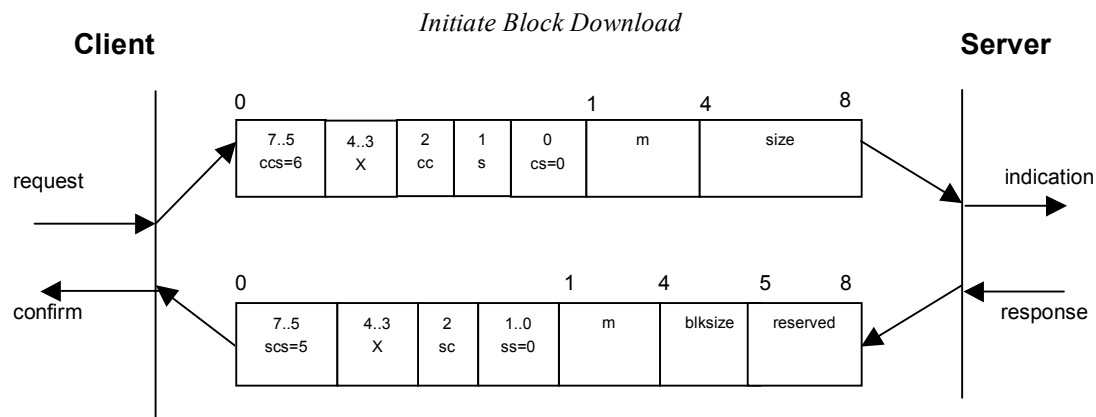

Figure 24: Initiate SDO Block Download Protocol

- **ccs**: client command specifier
6: block download
- **scs**: server command specifier
5: block download
- **s**: size indicator
0: data set size is not indicated
1: data set size is indicated
- **cs**: client subcommand
0: initiate download request
- **ss**: server subcommand
0: initiate download response
- **cc**: client CRC support
cc = 0: Client does not support generating CRC on data
cc = 1: Client supports generating CRC on data
- **sc**: server CRC support
sc = 0: Server does not support generating CRC on data
sc = 1: Server supports generating CRC on data
- **m**: multiplexor. It represents the index/sub-index of the data to be transfer by the SDO.
- **size**: download size in bytes
s = 0: size is reserved for further use, always 0
s = 1: size contains the number of bytes to be downloaded
Byte 4 contains the lsb and byte 7 the msb
- **blksize**: Number of segments per block with $0 < \text{blksize} < 128$.
- **X**: not used, always 0
- **reserved**: reserved for further use, always 0

9.2.2.2.10 Download SDO Block Segment Protocol

This protocol is used to implement the Block Download service.

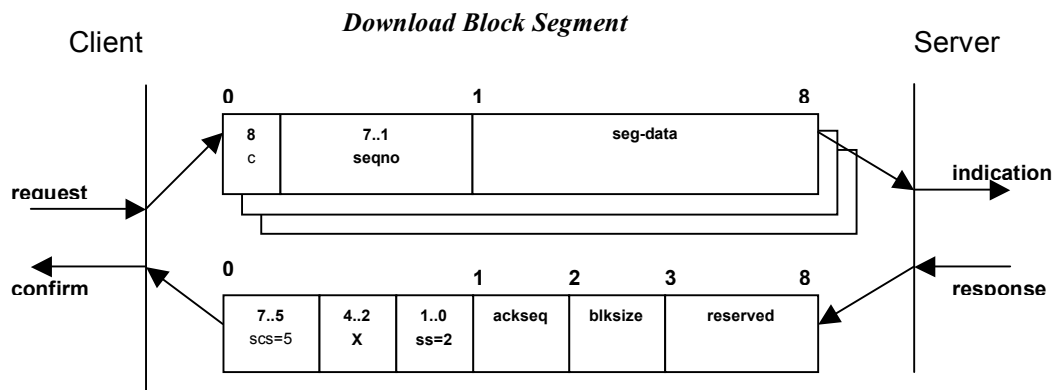

Figure 25: Download SDO Block Segment

- **scs**: server command specifier
 - 5: block download
- **ss**: server subcommand
 - 2: block download response
- **c**: indicates whether there are still more segments to be downloaded
 - 0: more segments to be downloaded
 - 1: no more segments to be downloaded, enter End SDO block download phase
- **seqno**: sequence number of segment $0 < \text{seqno} < 128$.
- **seg-data**: at most 7 bytes of segment data to be downloaded.
- **ackseq**: sequence number of last segment that was received successfully during the last block download. If **ackseq** is set to 0 the server indicates the client that the segment with the sequence number 1 was not received correctly and all segments have to be retransmitted by the client.
- **blksize**: Number of segments per block that has to be used by client for the following block download with $0 < \text{blksize} < 128$.
- **X**: not used, always 0
- **reserved**: reserved for further use, always 0

9.2.2.2.11 End SDO Block Download Protocol

This protocol is used to implement the End SDO Block Download service.

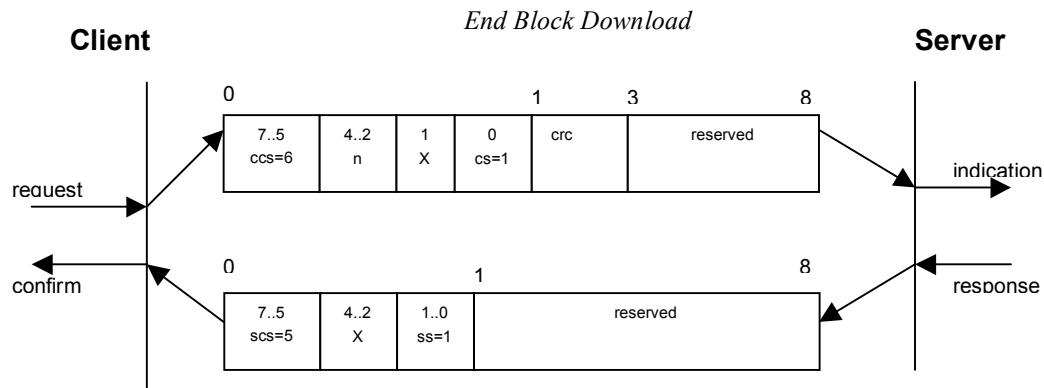

Figure 26: End SDO Block Download Protocol

- **ccs:** client command specifier
 - 6: block download
- **scs:** server command specifier
 - 5: block download
- **cs:** client subcommand
 - 1: end block download request
- **ss:** server subcommand
 - 1: end block download response
- **n:** indicates the number of bytes in the last segment of the last block that do not contain data. Bytes [8-n, 7] do not contain segment data.
- **crc:** 16 bit Cyclic Redundancy Checksum (CRC) for the whole data set. The algorithm for generating the CRC is described in 9.2.2.2.16. CRC is only valid if in Initiate Block Download cc and sc are set to 1 otherwise CRC has to be set to 0.
- **X:** not used, always 0
- **reserved:** reserved for further use, always 0

9.2.2.2.12 Upload SDO Block Protocol

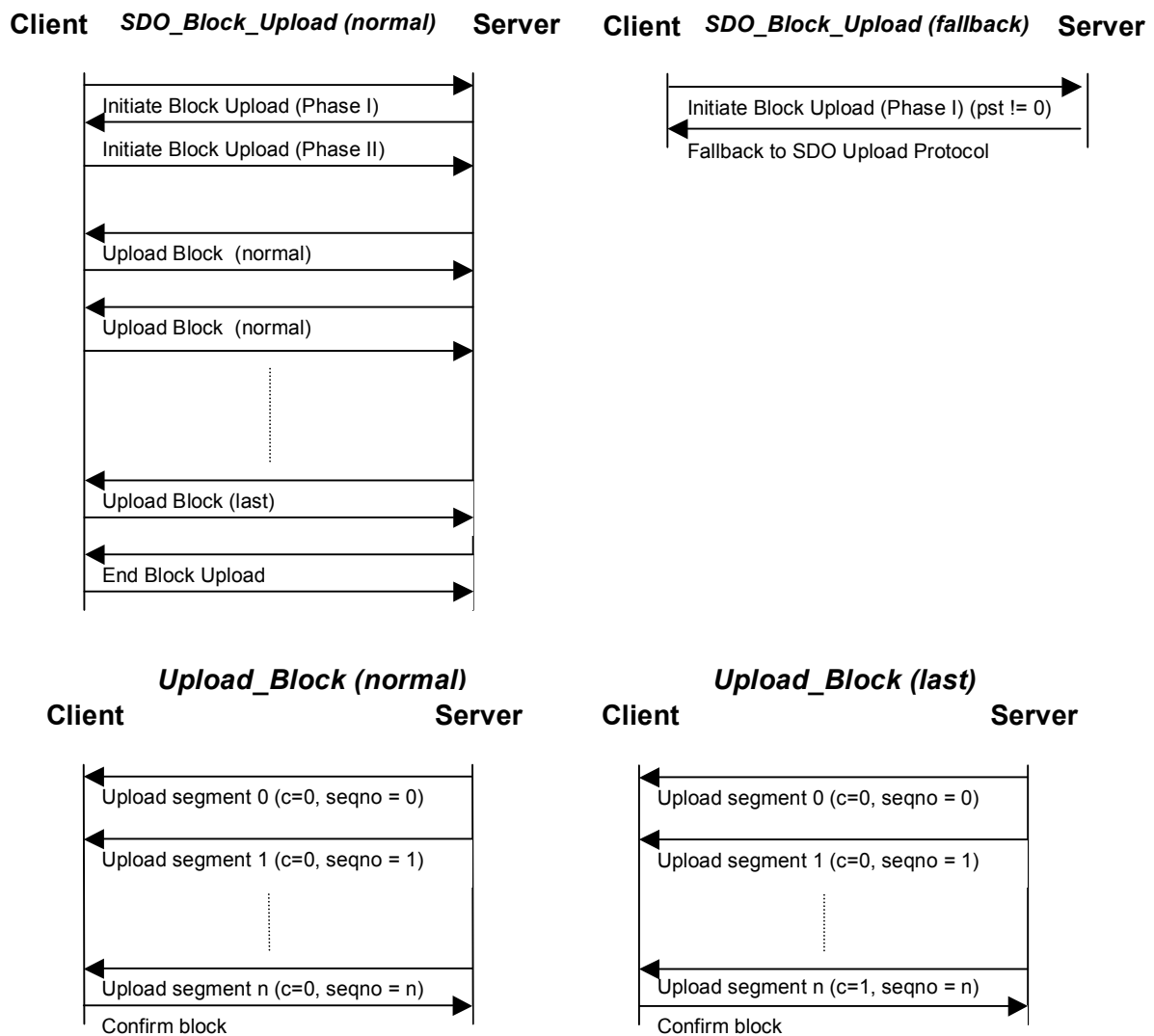

Figure 27: Upload SDO Block Protocol

This protocol is used to implement a SDO Block Upload service which starts with the Initiate SDO Block Upload service. The client can indicate a threshold value to the server which is the minimum value in bytes to increase transfer performance using the SDO Block Upload protocol instead of the SDO Upload protocol. If the data set size is less or equal this value the server can continue with the normal or expedited transfer of the SDO Block Upload protocol.

Otherwise SDOs are uploaded as a sequence of Upload SDO Block services. The SDO Upload Block sequence is terminated by:

- an uploaded segment within a block with the c-bit set to 1, indicating the completion of the block upload sequence.
- an Abort SDO Transfer request/indication, indicating the unsuccessful completion of the uploaded sequence.

The whole 'SDO Block Upload' service is terminated with the 'End SDO Block Upload' service. If client as well as server have indicated the ability to generate a CRC during the Initiate SDO Block Upload service the client has to generate the CRC on the received data. If this CRC differs from the CRC generated by the server the client has to indicate this with an 'Abort SDO Transfer' indication.

9.2.2.2.13 Initiate SDO Block Upload Protocol

This protocol is used to implement the Initiate SDO Block Upload service. If the value of the Protocol Switch Threshold parameter indicated by the client in the first request is less or equal the data set size to be uploaded the server can continue with the SDO Upload Protocol as described in 9.2.2.2.4.

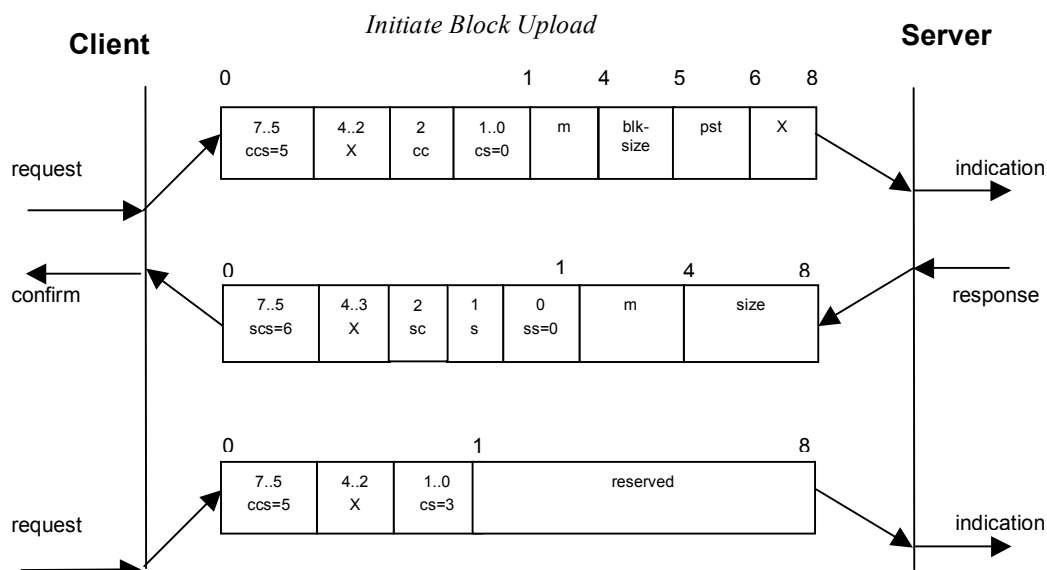

Figure 28: Initiate SDO Block Upload Protocol

- **ccs**: client command specifier
5: block upload
- **scs**: server command specifier
6: block upload
- **cs**: client subcommand
0: initiate upload request
3: start upload
- **ss**: server subcommand
0: initiate upload response
- **m**: multiplexor. It represents the index/sub-index of the data to be transfer by the SDO.
- **cc**: client CRC support
cc = 0: Client does not support generating CRC on data
cc = 1: Client supports generating CRC on data
- **sc**: server CRC support
sc = 0: Server does not support generating CRC on data
sc = 1: Server supports generating CRC on data
- **pst**: Protocol Switch Threshold in bytes to change the SDO transfer protocol
pst = 0: Change of transfer protocol not allowed.
pst > 0: If the size of the data in bytes that has to be uploaded is less or equal pst the server can optionally switch to the 'SDO Upload Protocol' by transmitting the server response of the 'SDO Upload Protocol' as described in 9.2.2.2.4.
- **s**: size indicator
0: data set size is not indicated
1: data set size is indicated
- **size**: upload size in bytes
s = 0: size is reserved for further use, always 0
s = 1: size contains the number of bytes to be downloaded
Byte 4 contains the lsb and byte 7 the msb
- **blksize**: Number of segments per block with $0 < \text{blksize} < 128$.
- **X**: not used, always 0
- **reserved**: reserved for further use, always 0

9.2.2.2.14 Upload SDO Block Segment Protocol

This protocol is used to implement the SDO Block Upload service.

Figure 29: Upload SDO Block Segment Protocol

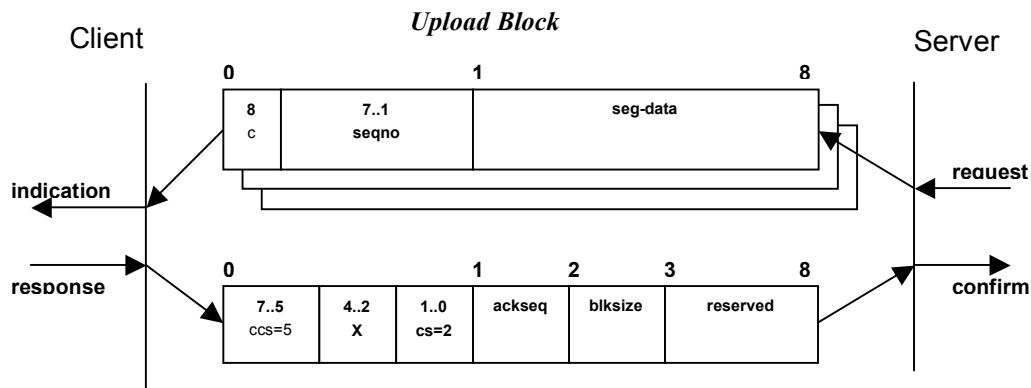

- **ccs:** client command specifier
 - 5: block upload
- **cs:** client subcommand
 - 2: block upload response
- **c:** indicates whether there are still more segments to be downloaded
 - 0: more segments to be uploaded
 - 1: no more segments to be uploaded, enter 'End block upload' phase
- **seqno:** sequence number of segment $0 < \text{seqno} < 128$.
- **seg-data:** at most 7 bytes of segment data to be uploaded.
- **ackseq:** sequence number of last segment that was received successfully during the last block upload. If ackseq is set to 0 the client indicates the server that the segment with the sequence number 1 was not received correctly and all segments have to be retransmitted by the server.
- **blksize:** Number of segments per block that has to be used by server for the following block upload with $0 < \text{blksize} < 128$.
- **X:** not used, always 0
- **reserved:** reserved for further use, always 0

9.2.2.2.15 End SDO Block Upload Protocol

This protocol is used to implement the End SDO Block Upload service.

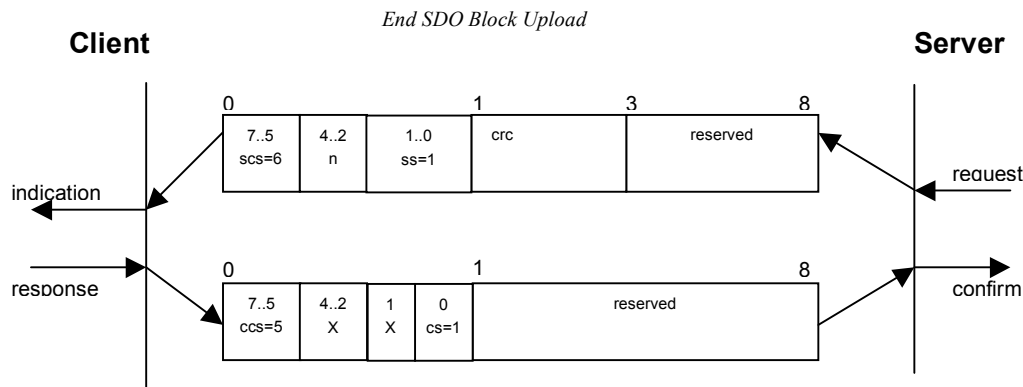

Figure 30: End SDO Block Upload Protocol

- **ccs**: client command specifier
 - 5: block upload
- **scs**: server command specifier
 - 6: block upload
- **cs**: client subcommand
 - 1: end block upload request
- **ss**: server subcommand
 - 1: end block upload response
- **n**: indicates the number of bytes in the last segment of the last block that do not contain data. Bytes [8-n, 7] do not contain segment data.
- **crc**: 16 bit Cyclic Redundancy Checksum (CRC) for the whole data set. The algorithm for generating the CRC is described in 9.2.2.2.16. CRC is only valid if in Initiate Block Upload cc and sc are set to 1 otherwise crc has to be set to 0.
- **X**: not used, always 0
- **reserved**: reserved for further use, always 0

9.2.2.2.16 CRC calculation algorithm to verify SDO Block Transfer

To verify the correctness of a SDO block upload/download client and server calculating a cyclic redundancy checksum (CRC) which is exchanged and verified during End SDO Block Download/Upload protocol. The check polynomial has the formula $x^{16} + x^{12} + x^5 + 1$. The calculation has to be made with an initial value of 0.

9.2.3 Synchronisation Object (SYNC)

The Synchronisation Object is broadcasted periodically by the SYNC producer. This SYNC provides the basic network clock. The time period between the SYNCs is specified by the standard parameter **communication cycle period** (see Object 1006h: Communication Cycle Period), which may be written by a configuration tool to the application devices during the boot-up process. There can be a time jitter in transmission by the SYNC producer corresponding approximately to the latency due to some other message being transmitted just before the SYNC.

In order to guarantee timely access to the CAN bus the SYNC is given a very high priority identifier (1005h). Devices which operate synchronously may use the SYNC object to synchronise their own timing with that of the Synchronisation Object producer. The details of this synchronisation are device dependent and do not fall within the scope of this document. Devices which require a more accurate common time base may use the high resolution synchronisation mechanism described in 9.3.2.

9.2.3.1 SYNC Services

The SYNC transmission follows the producer/consumer push model as described in 6.3.3. The service is unconfirmed.

Attributes:

- user type: one of the values {consumer, producer}
- data type: nil

9.2.3.2 SYNC Protocol

One unconfirmed service (Write SYNC) is defined.

Write SYNC

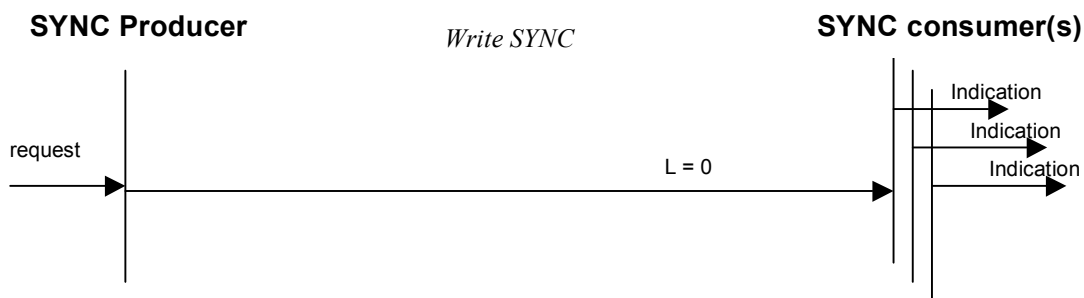

Figure 31: SYNC Protocol

- The SYNC does not carry any data (L=0).
The Identifier of the SYNC object is located at Object Index 1005h.

9.2.4 Time Stamp Object (TIME)

By means of the Time Stamp Object a common time frame reference is provided to devices. It contains a value of the type TIME_OF_DAY. The Identifier of the TIME Object is located at Object Index 1012h.

9.2.4.1 TIME Services

The Time Stamp Object transmission follows the producer/consumer push model as described in 6.3.3. The service is unconfirmed.

Attributes:

- user type: one of the values {consumer, producer}
- data type: TIME_OF_DAY

9.2.4.2 TIME Protocol

One unconfirmed service (Write TIME) is defined.

Write TIME

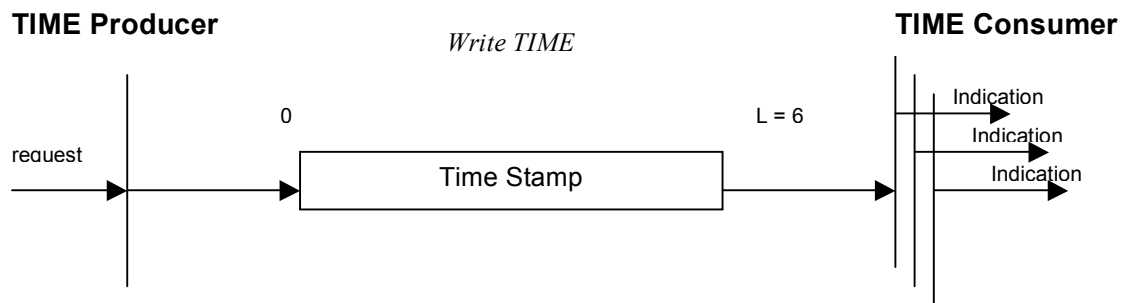

Figure 32: TIME Protocol

- **Time Stamp:** 6 bytes of the Time Stamp Object

9.2.5 Emergency Object (EMCY)

9.2.5.1 Emergency Object Usage

Emergency objects are triggered by the occurrence of a device internal error situation and are transmitted from an emergency producer on the device. Emergency objects are suitable for interrupt type error alerts. An emergency object is transmitted only once per 'error event'. As long as no new errors occur on a device no further emergency objects must be transmitted.

The emergency object may be received by zero or more emergency consumers. The reaction on the emergency consumer(s) is not specified and does not fall in the scope of this document.

By means of this specification emergency error codes (Table 21) and the error register (Table 48) are specified. Device specific additional information and the emergency condition do not fall into the scope of this specification.

Table 21: Emergency Error Codes

Error Code (hex)	Meaning
00xx	Error Reset or No Error
10xx	Generic Error
20xx	Current
21xx	Current, device input side
22xx	Current inside the device
23xx	Current, device output side
30xx	Voltage
31xx	Mains Voltage
32xx	Voltage inside the device
33xx	Output Voltage
40xx	Temperature
41xx	Ambient Temperature
42xx	Device Temperature
50xx	Device Hardware
60xx	Device Software
61xx	Internal Software
62xx	User Software
63xx	Data Set
70xx	Additional Modules
80xx	Monitoring
81xx	Communication
8110	CAN Overrun (Objects lost)
8120	CAN in Error Passive Mode
8130	Life Guard Error or Heartbeat Error
8140	recovered from bus off
8150	Transmit COB-ID collision
82xx	Protocol Error
8210	PDO not processed due to length error
8220	PDO length exceeded
90xx	External Error
F0xx	Additional Functions
FFxx	Device specific

The emergency object is optional. If a device supports the emergency object, it has to support at least the two error codes 00xx and 10xx. All other error codes are optional.

A device may be in one of two emergency states (Figure 33). Dependent on the transitions emergency objects will be transmitted. Links between the error state machine and the NMT state machine are defined in the device profiles.

0. After initialization the device enters the error free state if no error is detected. No error message is sent.
1. The device detects an internal error indicated in the first three bytes of the emergency message (error code and error register). The device enters the error state. An emergency object with the appropriate error code and error register is transmitted. The error code is filled in at the location of object 1003H (pre-defined error field).
2. One, but not all error reasons are gone. An emergency message containing error code 0000 (Error reset) may be transmitted together with the remaining errors in the error register and in the manufacturer specific error field.
3. A new error occurs on the device. The device remains in error state and transmits an emergency object with the appropriate error code. The new error code is filled in at the top of the array of error codes (1003H). It has to be guaranteed that the error codes are sorted in a timely manner (oldest error - highest sub-index, see Object 1003H).
4. All errors are repaired. The device enters the error free state and transmits an emergency object with the error code 'reset error / no error'.

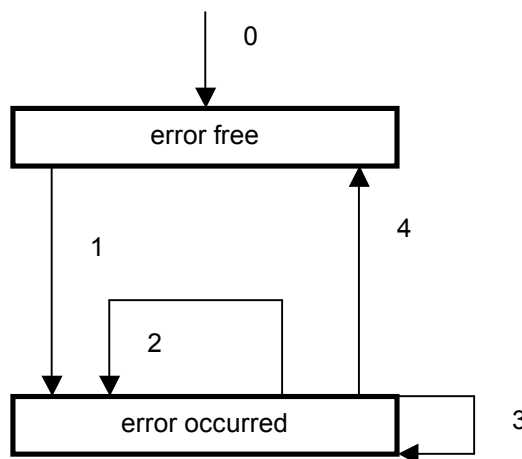

Figure 33: Emergency State Transition Diagram

9.2.5.2 Emergency Object Data

The Emergency Telegram consists of 8 bytes with the data as shown in Figure 34: Emergency Object Data.

Byte	0	1	2	3	4	5	6	7
Content	Emergency Error Code (see Table 21)		Error register (Object 1001H)	Manufacturer specific Error Field				

Figure 34: Emergency Object Data

9.2.5.3 Emergency Object Services

Emergency object transmission follows the “producer – consumer” push model as described in 6.3.3. The following object attributes are specified for emergency objects:

- user type: notifying device: producer
receiving devices: consumer
- data type: STRUCTURE OF
UNSIGNED(16) emergency_error_code,
UNSIGNED(8) error_register,
ARRAY (5) of UNSIGNED(8) manufacturer_specific_error_field
- inhibit time: Application specific

9.2.5.4 Emergency Object Protocol

One unconfirmed service (Write EMCY) is defined.

Write EMCY

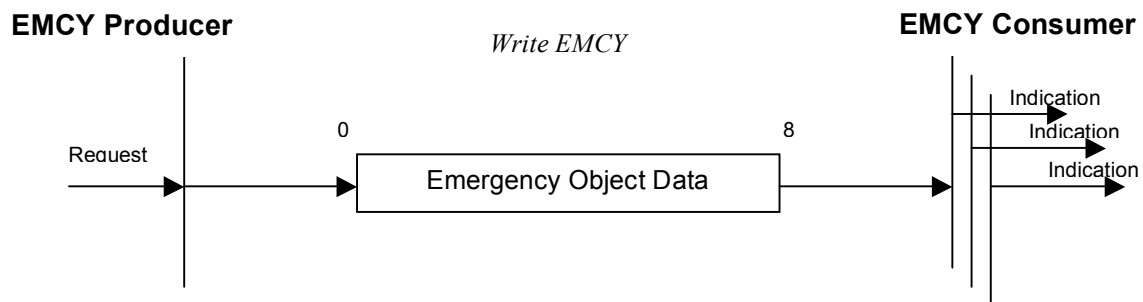

Figure 35: Emergency Object Protocol

It is not allowed to request an Emergency Object by a remote transmission request (RTR).

9.2.6 Network Management Objects

The Network Management (NMT) is node oriented and follows a master-slave structure. NMT objects are used for executing NMT services. Through NMT services, nodes are initialised, started, monitored, resetted or stopped. All nodes are regarded as NMT slaves. An NMT Slave is uniquely identified in the network by its Node-ID, a value in the range of [1..127].

NMT requires that one device in the network fulfils the function of the NMT Master.

9.2.6.1 NMT Services

9.2.6.1.1 Module Control Services

Through Module Control Services, the NMT master controls the state of the NMT slaves. The state attribute is one of the values {STOPPED, PRE-OPERATIONAL, OPERATIONAL, INITIALISING}. The Module Control Services can be performed with a certain node or with all nodes simultaneously. The NMT master controls its own NMT state machine via local services, which are implementation dependent. The Module Control Services except Start Remote Node can be initiated by the local application.

Start Remote Node

Through this service the NMT Master sets the state of the selected NMT Slaves to OPERATIONAL.

Table 22: Start Remote Node

<i>Parameter</i>	<i>Indication/Request</i>
Argument Node-ID All	Mandatory selection selection

The service is unconfirmed and mandatory. After completion of the service, the state of the selected remote nodes will be OPERATIONAL.

Stop Remote Node

Through this service the NMT Master sets the state of the selected NMT Slaves to STOPPED.

Table 23: Stop Remote Node

<i>Parameter</i>	<i>Request/Indication</i>
Argument Node-ID All	Mandatory selection selection

The service is unconfirmed and mandatory. After completion of the service, the state of the selected remote nodes will be STOPPED.

Enter Pre-Operational

Through this service the NMT Master sets the state of the selected NMT Slave(s) to "PRE-OPERATIONAL".

Table 24: Enter Pre-Operational

<i>Parameter</i>	<i>Request/Indication</i>
Argument Node-ID All	Mandatory selection selection

The service is unconfirmed and mandatory for all devices. After completion of the service, the state of the selected remote nodes will be PRE-OPERATIONAL.

Reset Node

Through this service the NMT Master sets the state of the selected NMT Slave(s) from any state to the "reset application" sub-state.

Table 25: Reset Node

Parameter	Request/Indication
Argument Node-ID All	Mandatory selection selection

The service is unconfirmed and mandatory for all devices. After completion of the service, the state of the selected remote nodes will be RESET APPLICATION.

Reset Communication

Through this service the NMT Master sets the state of the selected NMT Slave(s) from any state to the "reset communication" sub-state. After completion of the service, the state of the selected remote nodes will be RESET COMMUNICATION.

Table 26: Reset Communication

Parameter	Request/Indication
Argument Node-ID All	Mandatory selection selection

The service is unconfirmed and mandatory for all devices.

9.2.6.1.2 Error Control Services

Through Error control services the NMT detects failures in a CAN-based Network.

Local errors in a node may e.g. lead to a reset or change of state. The definition of these local errors does not fall into the scope of this specification.

Error Control services are achieved principally through periodically transmitting of messages by a device. There exist two possibilities to perform Error Control.

The guarding is achieved through transmitting guarding requests (Node guarding protocol) by the NMT Master. If a NMT Slave has not responded within a defined span of time (node life time) or if the NMT Slave's communication status has changed, the NMT Master informs its NMT Master Application about that event.

If Life guarding (NMT slave guarded NMT master) is supported, the slave uses the guard time and life-time factor from its Object Dictionary to determine the node life time. If the NMT Slave is not guarded within its life time, the NMT Slave informs its local Application about that event. If guard time and life time factor are 0 (default values), the NMT Slave does not guard the NMT Master.

Guarding starts for the slave when the first remote-transmit-request for its guarding identifier is received. This may be during the boot-up phase or later.

The heartbeat mechanism for a device is established through cyclically transmitting a message by a heartbeat producer. One or more devices in the network are aware of this heartbeat message. If the heartbeat cycle fails for the heartbeat producer the local application on the heartbeat consumer will be informed about that event.

The implementation of either guarding or heartbeat is mandatory.

Node Guarding Event

Through this service, the NMT service provider on the NMT Master indicates that a remote error occurred or has been resolved for the remote node identified by Node-ID.

Table 27: Node Guarding Event

<i>Parameter</i>	<i>Indication</i>
Argument Node-ID State Occurred Resolved	Mandatory mandatory mandatory selection selection

The service is provider initiated and optional.

Life Guarding Event

Through this service, the NMT service provider on an NMT Slave indicates that a remote error occurred or has been resolved.

Table 28: Life Guarding Event

<i>Parameter</i>	<i>Indication</i>
Argument State Occurred Resolved	Mandatory mandatory selection selection

The service is provider initiated and optional.

Heartbeat Event

Through this service, the Heartbeat consumer indicates that a heartbeat error occurred or has been resolved for the node identified by Node-ID.

Table 29: Heartbeat Event

<i>Parameter</i>	<i>Indication</i>
Argument Node-ID State Occurred Resolved	Mandatory mandatory mandatory selection selection

The service is consumer initiated and optional.

9.2.6.1.3 Bootup Service

Bootup Event

Through this service, the NMT slave indicates that a local state transition occurred from the state INITIALISING to the state PRE-OPERATIONAL.

Table 30: Bootup Event

<i>Parameter</i>	<i>Indication</i>
Argument None	Mandatory

The service is provider initiated and mandatory.

9.2.6.2 NMT Protocols

9.2.6.2.1 Module Control Protocols

Start Remote Node Protocol

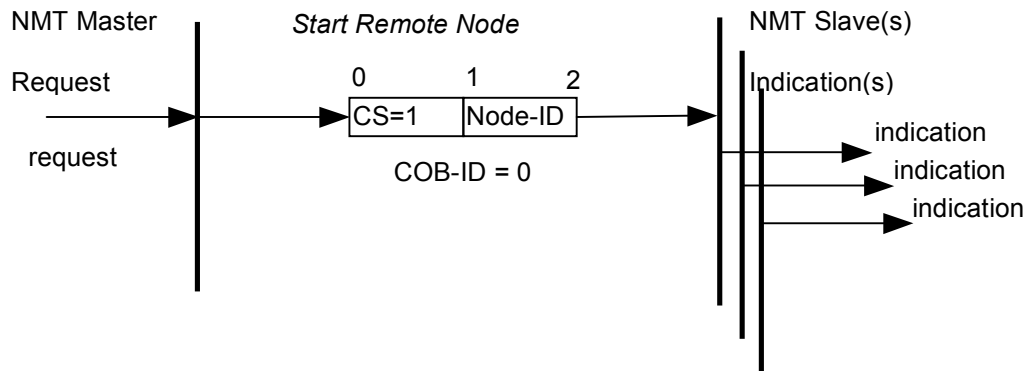

This protocol is used to implement the 'Start Remote Node' service.

Figure 36: Start Remote Node Protocol

- **cs:** NMT command specifier
1: start

Stop Remote Node Protocol

This protocol is used to implement the 'Stop Remote Node' service.

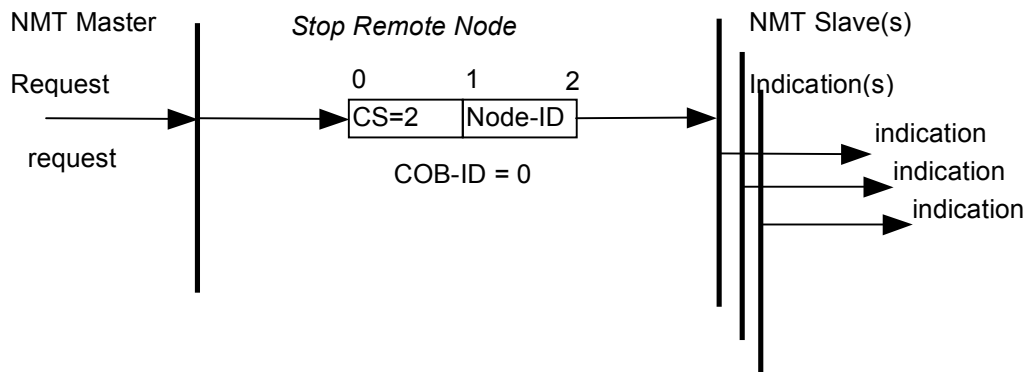

Figure 37: Stop Remote Node Protocol

- **cs:** NMT command specifier
2: stop

Enter Pre-Operational Protocol

The protocol is used to implement the 'Enter_Pre-Operational' service.

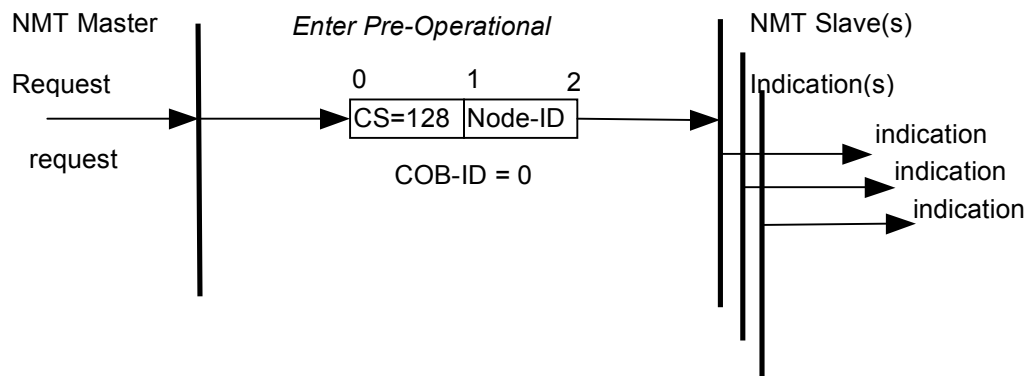
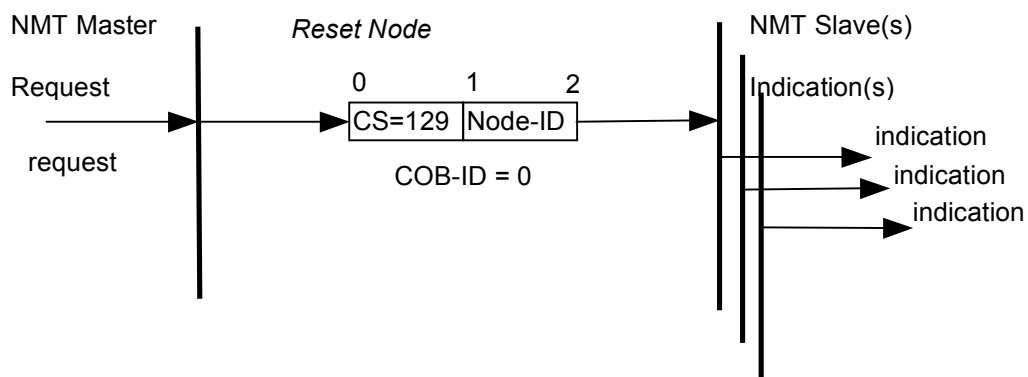

Figure 38: Enter Pre-Operational Protocol

- **cs:** NMT command specifier
128: enter PRE-OPERATIONAL

Reset Node Protocol



The protocol is used to implement the 'Reset Node' service.

Figure 39: Reset Node Protocol

- **cs:** NMT command specifier
129: Reset_Node

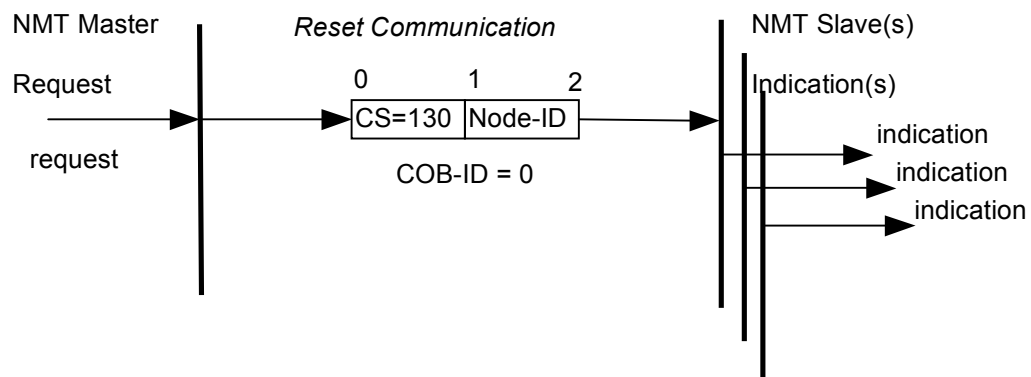
Reset Communication Protocol

The protocol is used to implement the 'Reset Communication' service.

Figure 40: Reset Communication Protocol

cs: NMT command specifier

130: Reset_Communication

9.2.6.2.2 Error Control Protocols

Node Guarding Protocol

This protocol is used to detect remote errors in the network. Each NMT Slave uses one remote COB for the Node Guarding Protocol. This protocol implements the provider initiated Error Control services.

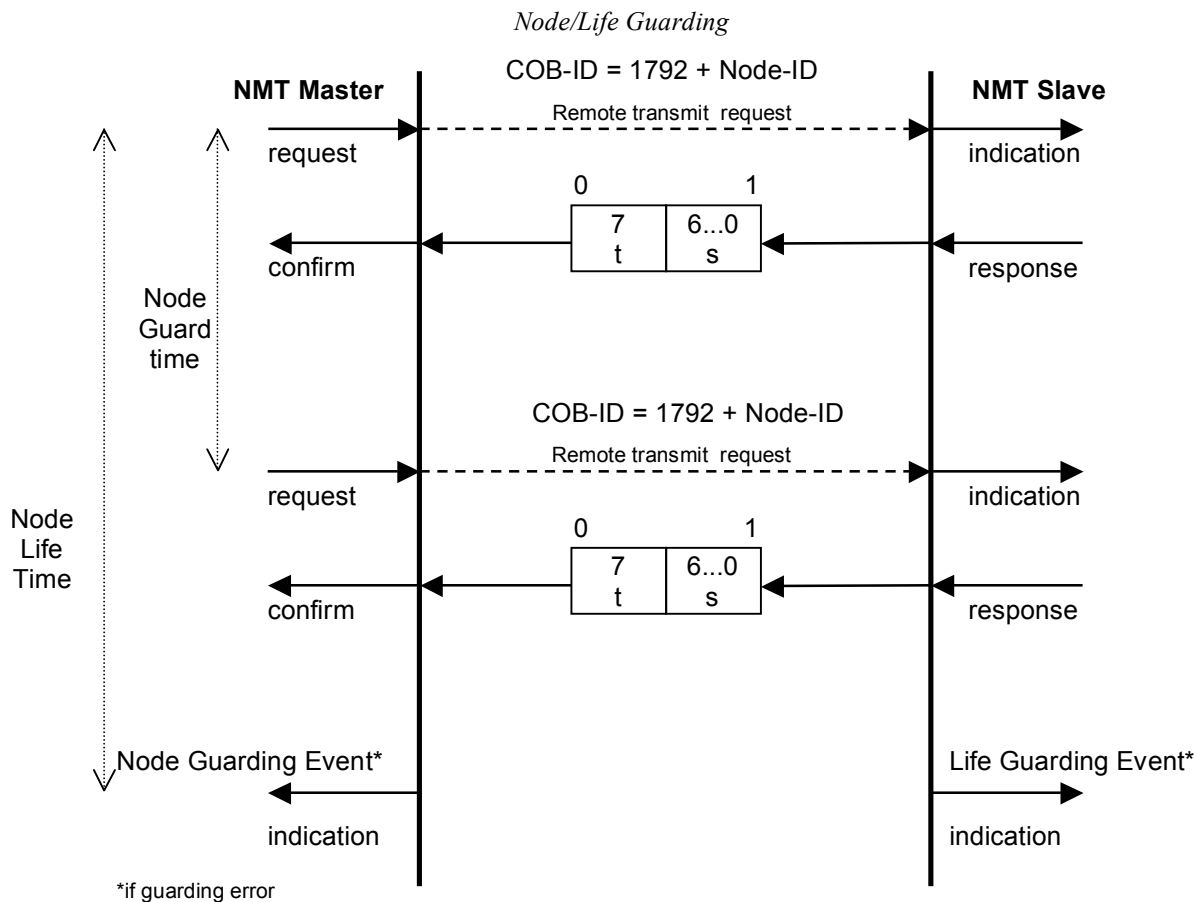

Figure 41: Node Guarding Protocol

s: the state of the NMT Slave

- 4: STOPPED
- 5: OPERATIONAL
- 127: PRE-OPERATIONAL

t: toggle bit. The value of this bit must alternate between two consecutive responses from the NMT Slave. The value of the toggle-bit of the first response after the Guarding Protocol becomes active, is 0. The Toggle Bit in the guarding protocol is only reset to 0 when `reset_communication` is passed (no other change of state resets the toggle bit). If a response is received with the same value of the toggle-bit as in the preceding response then the new response is handled as if it was not received.

The NMT Master polls each NMT Slave at regular time intervals. This time-interval is called the guard time and may be different for each NMT Slave. The response of the NMT Slave contains the state of that NMT Slave. The node life time is given by the guard time multiplied by the life time factor. The node life time can be different for each NMT Slave. If the NMT Slave has not been polled during its life time, a remote node error is indicated through the 'Life Guarding Event' service.

A remote node error is indicated through the 'Node guarding event' service if

- The remote transmit request is not confirmed within the node life time
- The reported NMT slave state does not match the expected state

If it has been indicated that a remote error has occurred and the errors in the guarding protocol have disappeared, it will be indicated that the remote error has been resolved through the 'Node Guarding Event' and 'Life Guarding Event' services.

For the guard time, and the life time factor there are default values specified at the appropriate Object Dictionary entries.

Heartbeat Protocol

The Heartbeat Protocol defines an Error Control Service without need for remote frames. A Heartbeat Producer transmits a Heartbeat message cyclically. One or more Heartbeat Consumer receive the indication. The relationship between producer and consumer is configurable via the object dictionary. The Heartbeat Consumer guards the reception of the Heartbeat within the Heartbeat Consumer Time. If the Heartbeat is not received within the Heartbeat Consumer Time a Heartbeat Event will be generated.

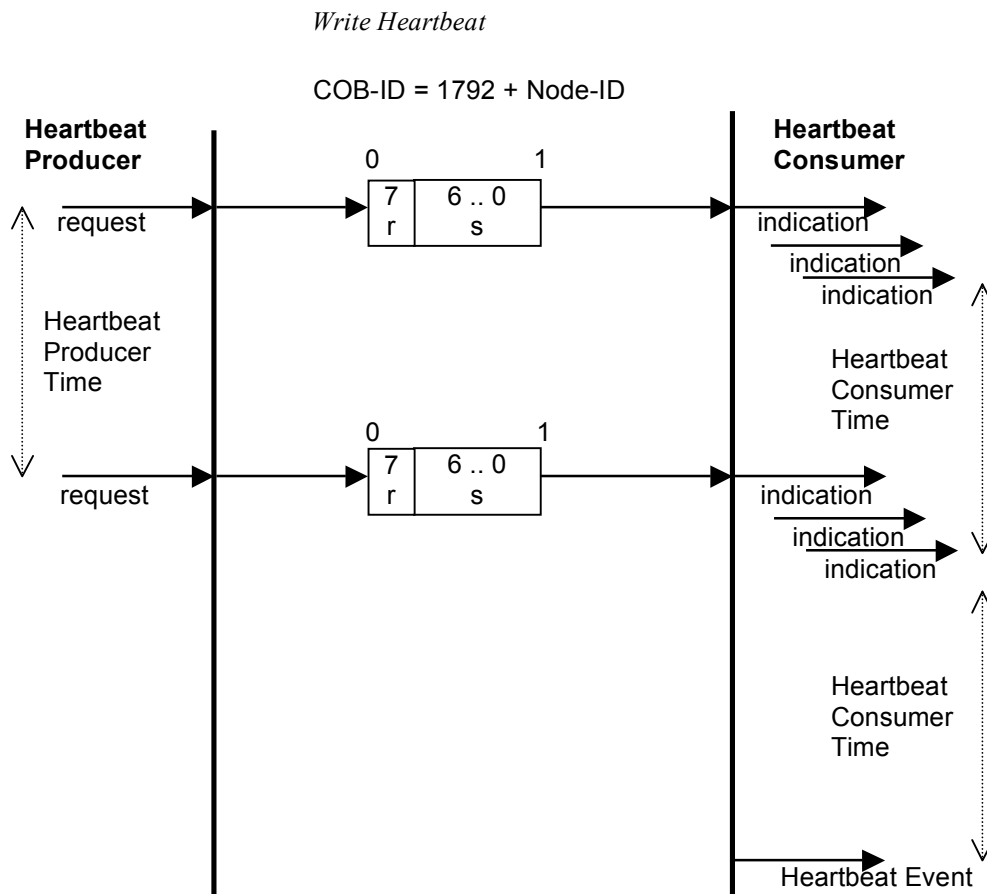

Figure 42: Heartbeat Protocol

r: reserved (always 0)

s: the state of the Heartbeat producer

- 0: BOOTUP
- 4: STOPPED
- 5: OPERATIONAL
- 127: PRE-OPERATIONAL

If the Heartbeat Producer Time is configured on a device the Heartbeat Protocol begins immediately. If a device starts with a value for the Heartbeat Producer Time unequal to 0 the Heartbeat Protocol starts on the state transition from INITIALISING to PRE-OPERATIONAL. In this case the Bootup Message is regarded as first heartbeat message. It is not allowed for one device to use both error control mechanisms Guarding Protocol and Heartbeat Protocol at the same time. If the heartbeat producer time is unequal 0 the heartbeat protocol is used.

9.2.6.2.3 Bootup Protocol

This protocol is used to signal that a NMT slave has entered the node state PRE-OPERATIONAL after the state INITIALISING. The protocol uses the same identifier as the error control protocols.

Bootup Event

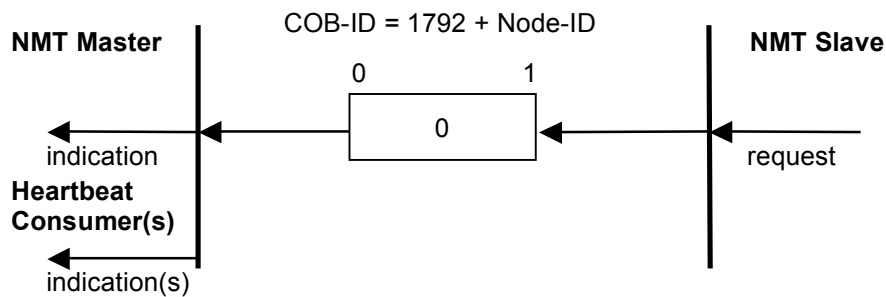

Figure 43: Bootup Protocol

One data byte is transmitted with value 0.

9.3 Synchronisation of the SYNC Consumer

9.3.1 Transmission of Synchronous PDO Messages

Synchronous transmission of a message means that the transmission of the message is fixed in time with respect to the transmission of the SYNC message. The synchronous message is transmitted within a given time window with respect to the SYNC transmission, and at most once for every period of the SYNC.

In general the fixing of the transmission time of synchronous PDO messages coupled with the periodicity of transmission of the SYNC message guarantees that devices may arrange to sample process variables from a process environment and apply their actuation in a co-ordinated fashion. A device consuming SYNC messages will provide synchronous PDO messages too. The reception of a SYNC message controls the moment when the application will interact with the process environment according to the contents of a synchronous PDO. The synchronous mechanism is intended for transferring commanded values and actual values on a fixed timely base.

In general a synchronous PDO with a commanded value will be received before a SYNC. The SYNC consuming device will actuate based on this synchronous PDO at the next SYNC message. The reception of a SYNC will also prompt a device operating in the cyclic mode to sample its feedback data and transmit a synchronous PDO with an actual value as soon as possible afterwards.

Depending upon its capabilities, a device may also be parameterised with the time period *synchronous window length* after the SYNC at which it is guaranteed that its commanded value has arrived. It may therefore perform any processing on the commanded value which is required in order to actuate at the next SYNC message.

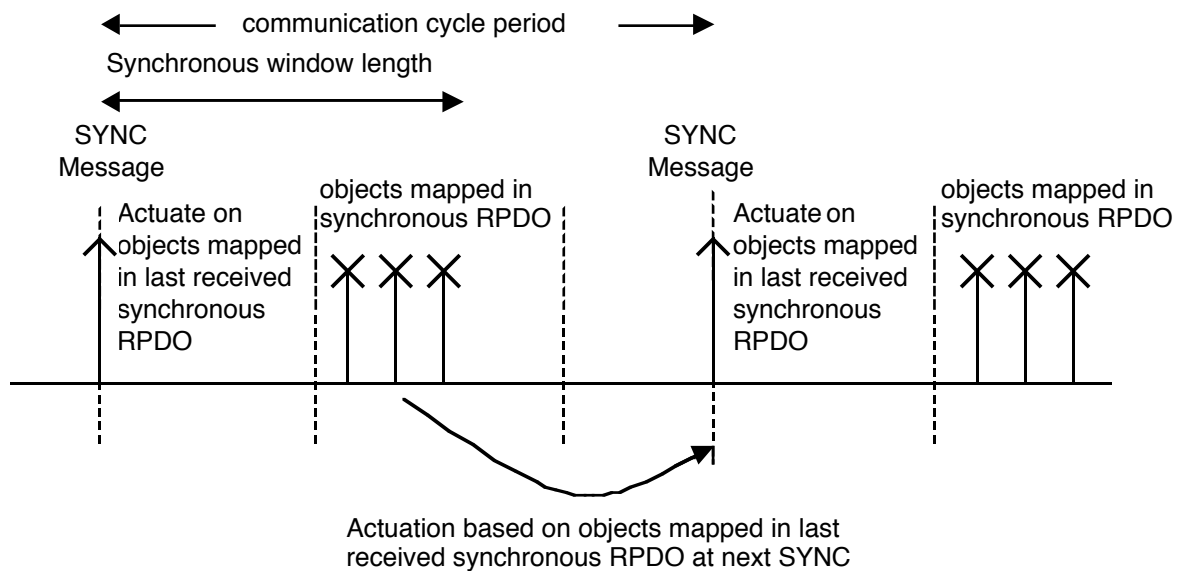

Figure 44: Bus Synchronisation and Actuation

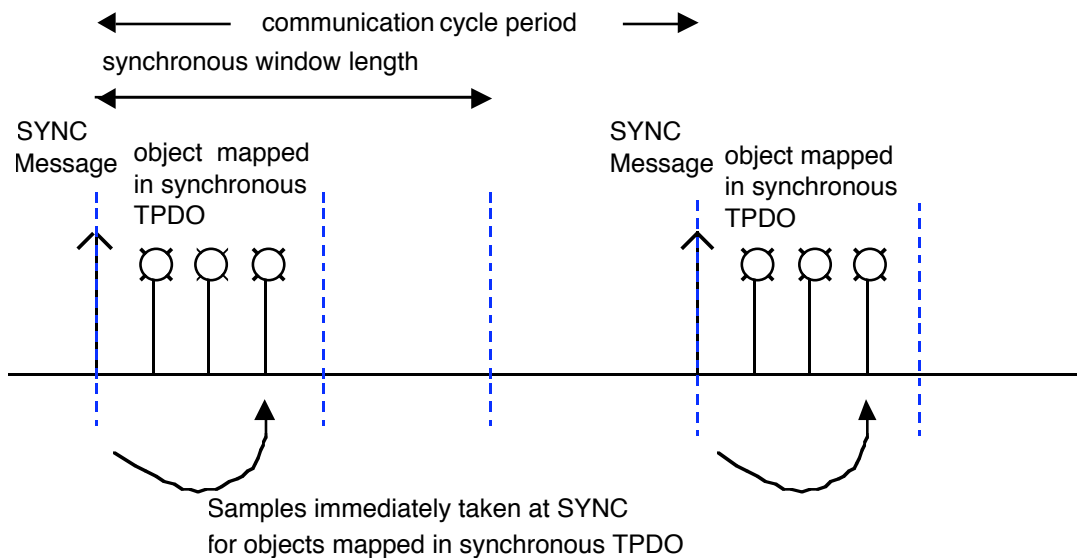

Figure 45: Bus Synchronisation and Sampling

9.3.2 Optional High Resolution Synchronisation Protocol

The synchronisation message carries no data and is easy to generate. However, the jitter of this SYNC depends on the bit rate of the bus as even the very high priority SYNC has to wait for the current message on the bus to be transmitted before it gains bus access.

Some time critical applications especially in large networks with reduced transmission rates require more accurate synchronisation; it may be necessary to synchronise the local clocks with an accuracy in the order of microseconds. This is achieved by using the optional high resolution synchronisation protocol which employs a special form of time stamp message (see Figure 46) to adjust the inevitable drift of the local clocks.

The SYNC producer time-stamps the interrupt generated at t_1 by the successful transmission of the SYNC message (this takes until t_2). After that (at t_4) he sends a time-stamp message containing the corrected time-stamp (t_1) for the SYNC transmission success indication. The SYNC consumer that have taken local time-stamps (t_3) on the reception (t_1) of the SYNC can now compare their corrected time-stamp (t_1) with the one received in the time-stamp message from the SYNC producer. The difference between these values determines the amount of time to adjust the local clock. With this protocol only the local latencies (t_2-t_1 on the SYNC producer and t_3-t_1 on the SYNC consumer) are time critical. These latencies depend on local parameters (like interrupt processing times and hardware delays) on the nodes which have to be determined once. The accuracy of this determination

is implementation specific, it forms the limiting factor of the synchronisation (or clock adjustment) accuracy. Note that each node only has to know its own latency time as the time-stamp message contains the corrected value t_1 and not t_2 .

The time-stamp is encoded as UNSIGNED32 with a resolution of 1 microsecond which means that the time counter restarts every 72 minutes. It is configured by mapping the high resolution time-stamp into a PDO.

It is reasonable to repeat the clock adjustment only when the maximum drift of the local clock exceeds the synchronisation accuracy. For most implementations this means that it is sufficient to add this time-stamp message to the standard SYNC once every second.

This principle enables the best accuracy that can be achieved with bus-based synchronisation, especially when implemented on CAN controllers that support time-stamping. Note that the accuracy is widely independent of the transmission rate. Further improvement requires separate hardware (e.g. wiring).

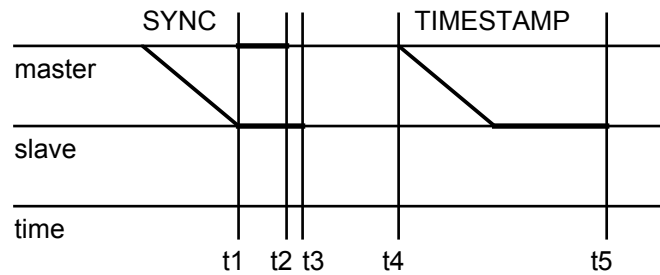

Figure 46: Optional High Resolution Synchronisation Protocol

9.4 Network Initialisation and System Boot-Up

9.4.1 Initialisation Procedure

In Figure 47 the general flow chart of the network initialisation process, controlled by a NMT Master Application or Configuration Application is shown.

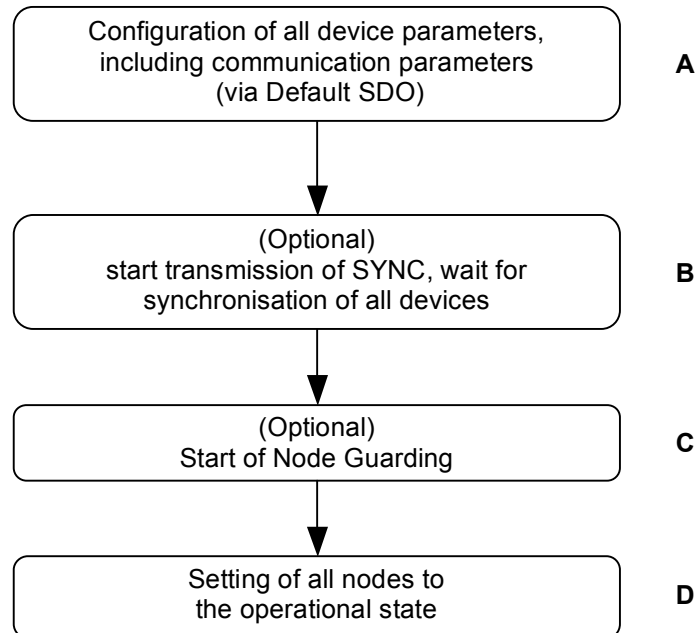

Figure 47: Flow Chart of the Network Initialisation Process

In step A the devices are in the node state PRE-OPERATIONAL which is entered automatically after power-on. In this state the devices are accessible via their Default-SDO using identifiers that have been assigned according to the Predefined Connection Set. In this step the configuration of device parameters takes place on all nodes which support parameter configuration.

This is done from a Configuration Application or Tool which resides on the node that is the client for the default SDOs. For devices that support these features the selection and/or configuration of PDOs, the mapping of application objects (PDO mapping), the configuration of additional SDOs and optionally the setting of COB-IDs may be performed via the Default-SDO objects.

In many cases a configuration is not even necessary as default values are defined for all application and communication parameters.

If the application requires the synchronisation of all or some nodes in the network, the appropriate mechanisms can be initiated in the optional Step B. It can be used to ensure that all nodes are synchronised by the SYNC object before entering the node state OPERATIONAL in step D. The first transmission of SYNC object starts within 1 sync cycle after entering the PRE-OPERATIONAL state. In Step C Node guarding can be activated (if supported) using the guarding parameters configured in step A.

With step D all nodes are enabled to communicate via their PDO objects.

9.4.2 NMT State Machine

9.4.2.1 Overview

In Figure 48 the state diagram of a device is shown. Devices enter the PRE-OPERATIONAL state directly after finishing the device initialisation. During this state device parameterisation and ID-allocation via SDO (e.g. using a configuration tool) is possible. Then the nodes can be switched directly into the OPERATIONAL state.

The NMT state machine determines the behaviour of the Communication function unit (see 6.2). The coupling of the application state machine to the NMT state machine is device dependent and falls into the scope of device profiles.

Minimal Boot-Up consists of one CAN telegram: a broadcast Start_Remote_Node message.

Figure 48: State Diagram of a Device

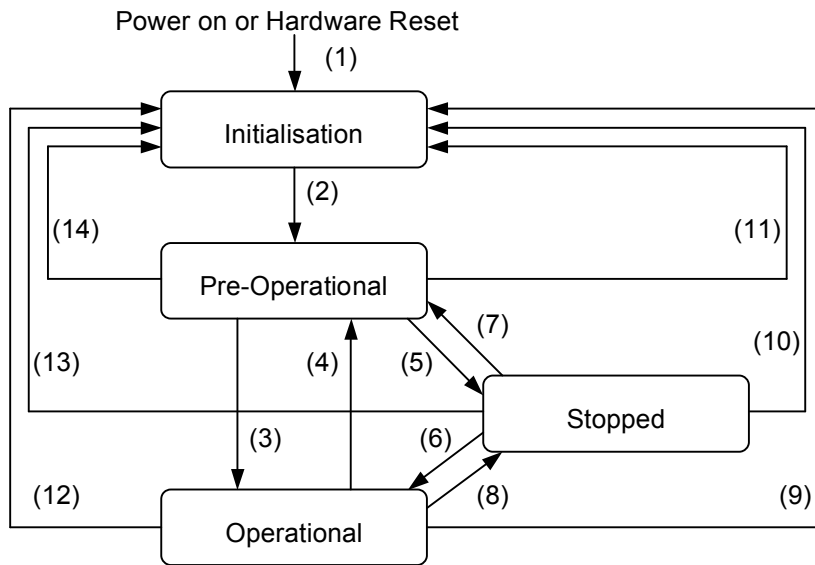

Table 31: Trigger for State Transition

(1)	At Power on the initialisation state is entered autonomously
(2)	Initialisation finished - enter PRE-OPERATIONAL automatically
(3),(6)	Start_Remote_Node indication
(4),(7)	Enter_PRE-OPERATIONAL_State indication
(5),(8)	Stop_Remote_Node indication
(9),(10),(11)	Reset_Node indication
(12),(13),(14)	Reset_Communication indication

9.4.2.2 States

9.4.2.2.1 Initialisation

The „initialisation“ state is divided into three sub-states (see Figure 49) in order to enable a complete or partial reset of a node.

1. **Initialising:** This is the first sub-state the device enters after power-on or hardware reset. After finishing the basic node initialisation the device enters autonomously into the state Reset_Application.
2. **Reset_Application:** In this state the parameters of the manufacturer specific profile area and of the standardised device profile area are set to their power-on values. After setting of the power-on values the state Reset_Communication is entered autonomously.
3. **Reset_Communication:** In this state the parameters of the communication profile area are set to their power-on values. After this the state Initialisation is finished and the device executes the write boot-up object service and enters the state PRE-OPERATIONAL.

Power-on values are the last stored parameters. If storing is not supported or has not been executed or if the reset was preceded by a restore_default command (object 1011H), the power-on values are the default values according to the communication and device profile specifications.

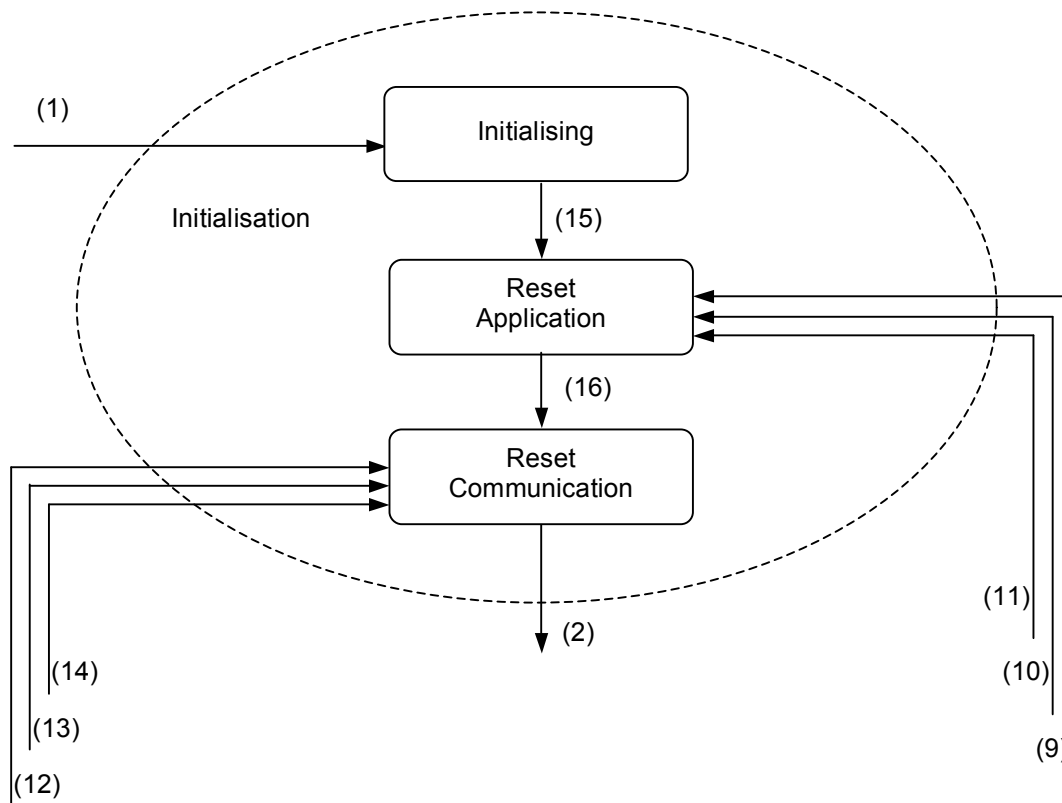

(1)	At Power on the initialisation state is entered autonomously
(2)	Initialisation finished - enter PRE-OPERATIONAL automatically
(12),(13),(14)	Reset_Communication indication
(9),(10), (11)	Reset_Node indication
(15)	Initialising finished – Reset_Application state is entered autonomously
(16)	Reset_Application is finished – Reset_Communication is entered autonomously

Figure 49: Structure of the Initialisation state

9.4.2.2.2 Pre-Operational

In the PRE-OPERATIONAL state, communication via SDOs is possible. PDOs do not exist, so PDO communication is not allowed. Configuration of PDOs, device parameters and also the allocation of application objects (PDO-mapping) may be performed by a configuration application. The node may be switched into the operational state directly by sending a Start_Remote_Node request.

9.4.2.2.3 Operational

In the OPERATIONAL state all communication objects are active. Transitioning to OPERATIONAL creates all PDOs; the constructor uses the parameters as described in the Object Dictionary. Object Dictionary Access via SDO is possible. Implementation aspects or the application state machine however may require to limit the access to certain objects whilst being operational, e.g. an object may contain the application program which cannot be changed during execution.

9.4.2.2.4 Stopped

By switching a device into the Stopped state it is forced to stop the communication altogether (except node guarding and heartbeat, if active). Furthermore, this state can be used to achieve certain application behaviour. The definition of this behaviour falls into the scope of device profiles.

9.4.2.3 States and Communication Object Relation

Table 32 shows the relation between communication states and communication objects. Services on the listed communication objects may only be executed if the devices involved in the communication are in the appropriate communication states.

Table 32: States and Communication Objects

	INITIALISING	PRE-OPERATIONAL	OPERATIONAL	STOPPED
PDO			X	
SDO		X	X	
Synchronisation Object		X	X	
Time Stamp Object		X	X	
Emergency Object		X	X	
Boot-Up Object	X			
Network Management Objects		X	X	X

9.4.2.4 State Transitions

State transitions are caused by

- reception of an NMT object used for module control services
- hardware reset
- Module Control Services locally initiated by application events, defined by device profiles

9.4.3 Pre-Defined Connection Set

In order to reduce configuration effort for simple networks a mandatory default identifier allocation scheme is defined. These identifiers are available in the PRE-OPERATIONAL state directly after initialisation (if no modifications have been stored). The objects SYNC, TIME STAMP, EMERGENCY and PDOs may be deleted and re-created with new identifiers by means of dynamic distribution. A device has to provide the corresponding identifiers only for the supported communication objects. The default profile ID-allocation scheme (Table 33 and Table 34) consists of a functional part, which determines the object priority and a Node-ID-part, which allows to distinguish between devices of the same functionality. This allows a peer-to-peer communication between a single master device and up

to 127 slave devices. It also supports the broadcasting of non-confirmed NMT-objects, SYNC- and TIME-STAMP-objects. Broadcasting is indicated by a Node-ID of zero. The pre-defined connection set supports one emergency object, one SDO, at maximum 4 Receive-PDOs (RPDO) and 4 Transmit-PDOs (TPDO) and the NMT objects.

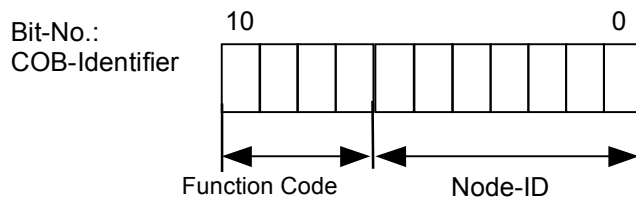

Figure 50: Identifier allocation scheme for the pre-defined connection set

Table 33 and Table 34 show the supported objects and their allocated COB-IDs.

Table 33: Broadcast Objects of the Pre-defined Connection Set

object	function code (binary)	resulting COB-ID	Communication Parameters at Index
NMT	0000	0	-
SYNC	0001	128 (80h)	1005h, 1006h, 1007h
TIME STAMP	0010	256 (100h)	1012h, 1013h

Table 34: Peer-to-Peer Objects of the Pre-defined Connection Set

object	function code (binary)	Resulting COB-IDs	Communication Parameters at Index
EMERGENCY	0001	129 (81h) – 255 (FFh)	1014h, 1015h
PDO1 (tx)	0011	385 (181h) – 511 (1FFh)	1800h
PDO1 (rx)	0100	513 (201h) – 639 (27Fh)	1400h
PDO2 (tx)	0101	641 (281h) – 767 (2FFh)	1801h
PDO2 (rx)	0110	769 (301h) – 895 (37Fh)	1401h
PDO3 (tx)	0111	897 (381h) – 1023 (3FFh)	1802h
PDO3 (rx)	1000	1025 (401h) – 1151 (47Fh)	1402h
PDO4 (tx)	1001	1153 (481h) – 1279 (4FFh)	1803h
PDO4 (rx)	1010	1281 (501h) – 1407 (57Fh)	1403h
SDO (tx)	1011	1409 (581h) – 1535 (5FFh)	1200h
SDO (rx)	1100	1537 (601h) – 1663 (67Fh)	1200h
NMT Error Control	1110	1793 (701h) – 1919 (77Fh)	1016h, 1017h

Table 34 has to be seen from the devices point of view.

The pre-defined connection set always applies to the standard CAN frame with 11-bit Identifier, even if extended CAN frames are present in the network.

Restricted COB-IDs

Any COB-ID listed in Table 35 is of restricted use. Such an restricted COB-ID have not to be used as COB-ID by any configurable communication object, neither for SYNC, TIME-STAMP, EMCY, PDO, and SDO.

Table 35: Restricted COB-IDs

COB-ID	used by object
0 (000h)	NMT
1 (001h)	reserved
257 (101h) – 384 (180h)	reserved
1409 (581h) – 1535 (5FFh)	default SDO (tx)
1537 (601h) – 1663 (67Fh)	default SDO (rx)
1760 (6E0h)	reserved
1793 (701h) – 1919 (77Fh)	NMT Error Control
2020 (780h) – 2047 (7FFh)	reserved

9.5 Object Dictionary

9.5.1 General Structure of the Object Dictionary

This section details the Object Dictionary structure and entries which are common to all devices. The format of the Object Dictionary entries is shown in Table 36 below:

Table 36: Format of Object Dictionary Headings

Index (hex)	Object (Symbolic Name)	Name	Type	Attrib.	M/O
----------------	---------------------------	------	------	---------	-----

The complete Object Dictionary consists of the six columns shown above. The **Index** column denotes the objects position within the Object Dictionary. This acts as a kind of address to reference the desired data field. The sub-index is not specified here. The sub-index is used to reference data fields within a complex object such as an array or record.

The **Object** column contains the Object Name according to Table 37 below and is used to denote what kind of object is at that particular index within the Object Dictionary. The following definitions are used:

Table 37: Object Dictionary Object Definitions

Object Name	Comments	Object Code
NULL	A dictionary entry with no data fields	0
DOMAIN	Large variable amount of data e.g. executable program code	2
DEFTYPE	Denotes a type definition such as a Boolean, UNSIGNED16, float and so on	5
DEFSTRUCT	Defines a new record type e.g. the PDO Mapping structure at 21h	6
VAR	A single value such as an UNSIGNED8, Boolean, float, Integer16, visible string etc.	7
ARRAY	A multiple data field object where each data field is a simple variable of the SAME basic data type e.g. array of UNSIGNED16 etc. Sub-index 0 is of UNSIGNED8 and therefore not part of the ARRAY data	8
RECORD	A multiple data field object where the data fields may be any combination of simple variables. Sub-index 0 is of UNSIGNED8 and therefore not part of the RECORD data	9

The **name** column provides a simple textual description of the function of that particular object. The **type** column gives information as to the type of the object. These include the following pre-defined types: BOOLEAN, floating point number, UNSIGNED Integer, Signed Integer, visible/octet string, time-of-day, time-difference and DOMAIN (see 9.1). It also includes the pre-defined complex data type PDO Mapping and may also include others which are either manufacturer or device specific. It is not possible to define records of records, arrays of records or records with arrays as fields of that record. In the case where an object is an array or a record the sub-index is used to reference one data field within the object.

The **Attribute** column defines the access rights for a particular object. The view point is from the bus into the device.

It can be of the following:

Table 38: Access Attributes for Data Objects

Attribute	Description
rw	read and write access
wo	write only access
ro	read only access
Const	read only access, value is constant

Optional objects listed in the Object Dictionary with the Attribute rw may be implemented as read only. Exceptions are defined in the detailed object specification.

The **M/O** column defines whether the object is **M**andatory or **O**ptional. A mandatory object must be implemented on a device. An optional object needs not to be implemented on a device. The support of certain objects or features however may require the implementation of related objects. In this case, the relations are described in the detailed object specification.

9.5.2 Dictionary Components

The overall layout of the Object Dictionary is shown in Table 39.

Index 01h - 1Fh contain the standard data types, index 20h - 23h contain predefined complex data types. The range of indices from 24h - 3Fh is not defined yet but reserved for future standard data structures.

The range of indices from 40h - 5Fh is free for manufacturers to define own complex data types. The range 60h - 7Fh contains device profile specific standard data types. From 80h – 9Fh device profile specific complex data types are defined. The range A0h – 25Fh is reserved for the data type definitions for Multiple Device Modules similar to the entries 60h – 9Fh. The entries from 360h – FFFh are reserved for possible future enhancements . The range 1000h - 1FFFh contains the communication specific Object Dictionary entries.

These parameters are called *communication entries*, their specification is common to all device types, regardless of the device profile they use. The objects in range 1000h - 1FFFh not specified by this document are reserved for further use. The range 2000h - 5FFFh is free for manufacturer specific profile definition.

The range 6000h - 9FFFh contains the standardised device profile parameters. The range A000h - FFFFh is reserved for future use.

9.5.3 Data Type Entry Specification

The static data types are placed in the Object Dictionary for definition purposes only. However, indices in the range 0001h - 0007h can be mapped as well in order to define the appropriate space in the RPDO as not being used by this device (do not care). The indices 0009h - 000Bh, 000Fh can not be mapped in a PDO.

The order of the data types is as follows:

Table 39: Object Dictionary Data Types

Index	Object	Name
0001	DEFTYPE	BOOLEAN
0002	DEFTYPE	INTEGER8
0003	DEFTYPE	INTEGER16
0004	DEFTYPE	INTEGER32
0005	DEFTYPE	UNSIGNED8
0006	DEFTYPE	UNSIGNED16
0007	DEFTYPE	UNSIGNED32
0008	DEFTYPE	REAL32
0009	DEFTYPE	VISIBLE_STRING
000A	DEFTYPE	OCTET_STRING

000B	DEFTYPE	UNICODE_STRING
000C	DEFTYPE	TIME_OF_DAY
000D	DEFTYPE	TIME_DIFFERENCE
000E	reserved	
000F	DEFTYPE	DOMAIN
0010	DEFTYPE	INTEGER24
0011	DEFTYPE	REAL64
0012	DEFTYPE	INTEGER40
0013	DEFTYPE	INTEGER48
0014	DEFTYPE	INTEGER56
0015	DEFTYPE	INTEGER64
0016	DEFTYPE	UNSIGNED24
0017	reserved	
0018	DEFTYPE	UNSIGNED40
0019	DEFTYPE	UNSIGNED48
001A	DEFTYPE	UNSIGNED56
001B	DEFTYPE	UNSIGNED64
001C-001F	reserved	
0020	DEFSTRUCT	PDO_COMMUNICATION_PARAMETER
0021	DEFSTRUCT	PDO_MAPPING
0022	DEFSTRUCT	SDO_PARAMETER
0023	DEFSTRUCT	IDENTITY
0024-003F	reserved	
0040-005F	DEFSTRUCT	Manufacturer Specific Complex Data Types
0060-007F	DEFTYPE	Device Profile (0) Specific Standard Data Types
0080-009F	DEFSTRUCT	Device Profile (0) Specific Complex Data Types
00A0-00BF	DEFTYPE	Device Profile 1 Specific Standard Data Types
00C0-00DF	DEFSTRUCT	Device Profile 1 Specific Complex Data Types
00E0-00FF	DEFTYPE	Device Profile 2 Specific Standard Data Types
0100-011F	DEFSTRUCT	Device Profile 2 Specific Complex Data Types
0120-013F	DEFTYPE	Device Profile 3 Specific Standard Data Types
0140-015F	DEFSTRUCT	Device Profile 3 Specific Complex Data Types
0160-017F	DEFTYPE	Device Profile 4 Specific Standard Data Types
0180-019F	DEFSTRUCT	Device Profile 4 Specific Complex Data Types
01A0-01BF	DEFTYPE	Device Profile 5 Specific Standard Data Types
01C0-01DF	DEFSTRUCT	Device Profile 5 Specific Complex Data Types
01E0-01FF	DEFTYPE	Device Profile 6 Specific Standard Data Types
0200-021F	DEFSTRUCT	Device Profile 6 Specific Complex Data Types
0220-023F	DEFTYPE	Device Profile 7 Specific Standard Data Types
0240-025F	DEFSTRUCT	Device Profile 7 Specific Complex Data Types

The data type representations used are detailed in 9.1. Every device does not need to support all the defined data types. A device only has to support the data types it uses with the objects in the range 1000h - 9FFFh.

The predefined complex data-types are placed after the standard data-types. Four types are defined at present, the **PDO CommPar** record (**PDO_COMMUNICATION_PARAMETER**), the **PDO Mapping**

record (**PDO_MAPPING**), the **SDO Parameter** record (**SDO_PARAMETER**) and the **Identity** record (**IDENTITY**). They are placed at index 20h, 21h, 22h and 23h.

For devices or device profiles that provide Multiple Device Modules like multiple axis controllers e.g. the DEFTYPE / DEFSTRUCT mechanism is enhanced for each virtual device with an offset of 40h for up to 7 additional virtual devices.

A device may optionally provide the length of the standard data types encoded as UNSIGNED32 at read access to the index that refers to the data type. E.g. index 000Ch (Time of Day) contains the value 30h=48dec as the data type „Time of Day“ is encoded using a bit sequence of 48 bit. If the length is variable (e.g. 000Fh = Domain), the entry contains 0h.

For the supported complex data types a device may optionally provide the structure of that data type at read access to the corresponding data type index. Sub-index 0 then provides the number of entries at this index not counting sub-indices 0 and 255 and the following sub-indices contain the data type according to Table 39 encoded as UNSIGNED8. The entry at Index 20h describing the structure of the PDO Communication Parameter then looks as follows (see also objects 1400h – 15FFh):

Table 40: complex data type example

Subindex	Value	(Description)
0h	04h	(4 sub indices follow)
1h	07h	(UNSIGNED32)
2h	05h	(UNSIGNED8)
3h	06h	(UNSIGNED16)
4h	05h	(UNSIGNED8)

Standard (simple) and complex manufacturer specific data types can be distinguished by attempting to read sub-index 1h: At a complex data type the device returns a value and sub-index 0h contains the number of sub-indices that follow, at a standard data type the device aborts the SDO transfer as no sub-index 1h available.

Note that some entries of data type UNSIGNED32 have the character of a structure (e.g. PDO COB-ID entry, see Figure 65).

9.5.3.1 Organisation of structured Object Dictionary Entries

If an Object Dictionary entry (index) contains several sub-indices, then sub-index 0 describes the highest available sub-index that follows, not considering FFh. This entry is encoded as UNSIGNED8. Sub-index FFh describes the structure of the entry by providing the data type and the object type of the entry. It is encoded as UNSIGNED32 and organised as follows:

	MSB	LSB	
Bits	31-16	15-8	7-0
Value	Reserved (value: 00 00h)	Data Type (see Table 39)	Object (see Table 37)
Encoded as	-	UNSIGNED8	UNSIGNED8

Figure 51: structure sub-index FFh

It is optional to support sub-index FFh. If it is supported throughout the Object Dictionary and the structure of the complex data types is provided as well, it enables one to upload the entire structure of the Object Dictionary.

9.5.4 Specification of Predefined Complex Data Types

This section describes the structure of the predefined complex data types used for communication. The value range and the meaning is explained at the detailed description of the objects using these types.

9.5.4.1 PDO Communication Parameter Record Specification

Table 41: PDO Communication Parameter Record

Index	Sub-Index	Field in PDO Communication Parameter Record	Data Type
0020h	0h	number of supported entries in the record	UNSIGNED8
	1h	COB-ID	UNSIGNED32
	2h	transmission type	UNSIGNED8
	3h	inhibit time	UNSIGNED16
	4h	reserved	UNSIGNED8
	5h	event timer	UNSIGNED16

9.5.4.2 PDO Mapping Parameter Record Specification

Table 42: PDO Mapping Parameter Record

Index	Sub-Index	Field in PDO Parameter Mapping Record	Data Type
0021h	0h	number of mapped objects in PDO	UNSIGNED8
	1h	1st object to be mapped	UNSIGNED32
	2h	2 nd object to be mapped	UNSIGNED32
⋮ ⋮	⋮ ⋮	⋮ ⋮	⋮ ⋮
	40h	64 th object to be mapped	UNSIGNED32

9.5.4.3**9.5.4.4 SDO Parameter Record Specification**

Table 43: SDO Parameter Record

Index	Sub-Index	Field in SDO Parameter Record	Data Type
0022h	0h	number of supported entries	UNSIGNED8
	1h	COB-ID client -> server	UNSIGNED32
	2h	COB-ID server -> client	UNSIGNED32
	3h	node ID of SDO's client resp. server	UNSIGNED8

9.5.4.5 Identity Record Specification

Table 44: Identity Record

Index	Sub-Index	Field in Identity Record	Data Type
0023h	0h	number of supported entries	UNSIGNED8
	1h	Vendor-ID	UNSIGNED32
	2h	Product code	UNSIGNED32
	3h	Revision number	UNSIGNED32
	4h	Serial number	UNSIGNED32

9.6 Communication Profile Specification

9.6.1 Detailed Object Specification

The structure of the Object Dictionary entries is described in the following manner: All device, interface and application profiles based on this communication profile have to follow this structure.

Table 45: Format of an Object Description

OBJECT DESCRIPTION

INDEX	Profile Index Number
Name	Name of parameter
Object Code	Variable classification
Data Type	Data type classification
Category	Optional or Mandatory

The Object Code must be one of those defined in OBJECT DESCRIPTION Table 45 above. For better readability, the Object Description additionally contains the symbolic Object Name.

Table 46: Object Value Description Format

ENTRY DESCRIPTION

Sub-Index	Number of sub-indices being described (field only used for Arrays, Records and Structures)
Description	Descriptive name of the Sub-Index (field only used for Arrays, Records and Structures)
Data Type	Data type classification (field only used for Records and Structures)
Entry Category	Specifies if the Entry is Optional or Mandatory or Conditional in case the Object is present
Access	Read Only (ro) or Read/Write (rw) or Write Only (wo) or Const. In OPERATIONAL state the Access to Object Dictionary Entries may be limited, e.g set to ro.
PDO Mapping	Optional/Default/No - can this object be mapped to a PDO. Description: Optional: Object may be mapped into a PDO Default: Object is part of the default mapping (see device profile) No: Object must not be mapped into a PDO
Value Range	range of possible values, or name of data type for full range
Default Value	No: not defined by this specification Value: default value of an object after device initialisation

For simple variables the value description appears once without the sub-index field and entry category. For complex data types the value description must be defined for each element (sub-index).

9.6.2 Overview Object Dictionary Entries for Communication

Table 47 gives an overview over the Object Dictionary entries defined by the communication profile:

Table 47: Standard Objects

Index (hex)	Object (Symbolic Name)	Name	Type	Acc. ¹	M/O
1000	VAR	device type	UNSIGNED32	ro	M

¹ Access type listed here may vary for certain sub-indices. See detailed object specification.

1001	VAR	error register	UNSIGNED8	ro	M
1002	VAR	manufacturer status register	UNSIGNED32	ro	O
1003	ARRAY	pre-defined error field	UNSIGNED32	ro	O
1004	reserved for compatibility reasons				
1005	VAR	COB-ID SYNC	UNSIGNED32	rw	O
1006	VAR	communication cycle period	UNSIGNED32	rw	O
1007	VAR	synchronous window length	UNSIGNED32	rw	O
1008	VAR	manufacturer device name	Vis-String	const	O
1009	VAR	manufacturer hardware version	Vis-String	const	O
100A	VAR	manufacturer software version	Vis-String	const	O
100B	reserved for compatibility reasons				
100C	VAR	guard time	UNSIGNED16	rw	O
100D	VAR	life time factor	UNSIGNED8	rw	O
100E	reserved for compatibility reasons				
100F	reserved for compatibility reasons				
1010	ARRAY	store parameters	UNSIGNED32	rw	O
1011	ARRAY	restore default parameters	UNSIGNED32	rw	O
1012	VAR	COB-ID TIME	UNSIGNED32	rw	O
1013	VAR	high resolution time stamp	UNSIGNED32	rw	O
1014	VAR	COB-ID EMCY	UNSIGNED32	rw	O
1015	VAR	Inhibit Time EMCY	UNSIGNED16	rw	O
1016	ARRAY	Consumer heartbeat time	UNSIGNED32	rw	O
1017	VAR	Producer heartbeat time	UNSIGNED16	rw	O
1018	RECORD	Identity Object	Identity (23h)	ro	M
1019		reserved			
.....
11FF		reserved			
Server SDO Parameter					
1200	RECORD	1 st Server SDO parameter	SDO Parameter (22h)	ro	O
1201	RECORD	2 nd Server SDO parameter	SDO Parameter (22h)	rw	M/O**
.....
127F	RECORD	128 th Server SDO parameter	SDO Parameter (22h)	rw	M/O**
Client SDO Parameter					
1280	RECORD	1 st Client SDO parameter	SDO Parameter (22h)	rw	M/O**
1281	RECORD	2 nd Client SDO parameter	SDO Parameter (22h)	rw	M/O**
.....
12FF	RECORD	128 th Client SDO parameter	SDO Parameter (22h)	rw	M/O**
1300		reserved			
.....
13FF		reserved			
Receive PDO Communication Parameter					
1400	RECORD	1 st receive PDO Parameter	PDO CommPar (20h)	rw	M/O*
1401	RECORD	2 nd receive PDO Parameter	PDO CommPar (20h)		M/O*
.....
15FF	RECORD	512 th receive PDO Parameter	PDO CommPar (20h)	rw	M/O*
Receive PDO Mapping Parameter					
1600	RECORD	1 st receive PDO mapping	PDO Mapping (21h)	rw	M/O*
1601	RECORD	2 nd receive PDO mapping	PDO Mapping (21h)	rw	M/O*

.....
17FF	RECORD	512 th receive PDO mapping	PDO Mapping (21h)	rw	M/O*
Transmit PDO Communication Parameter					
1800	RECORD	1 st transmit PDO Parameter	PDO CommPar (20h)	rw	M/O*
1801	RECORD	2 nd transmit PDO Parameter	PDO CommPar (20h)	rw	M/O*
.....
19FF	RECORD	512 th transmit PDO Parameter	PDO CommPar (20h)	rw	M/O*
Transmit PDO Mapping Parameter					
1A00	RECORD	1 st transmit PDO mapping	PDO Mapping (21h)	rw	M/O*
1A01	RECORD	2 nd transmit PDO mapping	PDO Mapping (21h)	rw	M/O*
.....
1BFF	RECORD	512 th transmit PDO mapping	PDO Mapping (21h)	rw	M/O*

* If a device supports PDOs, the according PDO communication parameter and PDO mapping entries in the Object Dictionary are mandatory. These may be read_only.

** If a device supports SDOs, the according SDO parameters in the Object Dictionary are mandatory.

9.6.3 Detailed Specification of Communication Profile specific Objects

Object 1000h: Device Type

Contains information about the device type. The object at index 1000h describes the type of device and its functionality. It is composed of a 16-bit field which describes the device profile that is used and a second 16-bit field which gives additional information about optional functionality of the device. The Additional Information parameter is device profile specific. Its specification does not fall within the scope of this document, it is defined in the appropriate device profile. The value 0000h indicates a device that does not follow a standardised device profile. For multiple device modules the Additional Information parameter contains FFFFh and the device profile number referenced by object 1000h is the device profile of the first device in the Object Dictionary. All other devices of a multiple device module identify their profiles at objects 67FFh + x * 800h with x = internal number of the device (0 – 7). These entries describe the device type of the preceding device.

OBJECT DESCRIPTION

INDEX	1000h
Name	device type
Object Code	VAR
Data Type	UNSIGNED32
Category	Mandatory

ENTRY DESCRIPTION

Access	ro
PDO Mapping	No
Value Range	UNSIGNED32
Default Value	No

Byte: MSB

LSB

Additional Information	Device Profile Number
------------------------	-----------------------

Figure 52: Structure of the Device Type Parameter

Object 1001h: Error Register

This object is an error register for the device. The device can map internal errors in this byte. This entry is mandatory for all devices. It is a part of an Emergency object.

OBJECT DESCRIPTION

INDEX	1001h
Name	error register
Object Code	VAR
Data Type	UNSIGNED8
Category	Mandatory

ENTRY DESCRIPTION

Access	ro
PDO Mapping	Optional
Value Range	UNSIGNED8
Default Value	No

Table 48: Structure of the Error Register

Bit	M/O	Meaning
0	M	generic error
1	O	current
2	O	voltage
3	O	temperature
4	O	communication error (overrun, error state)
5	O	device profile specific
6	O	Reserved (always 0)
7	O	manufacturer specific

If a bit is set to 1 the specified error has occurred. The only mandatory error that has to be signalled is the generic error. The generic error is signaled at any error situation.

Object 1002h: Manufacturer Status Register

This object is a common status register for manufacturer specific purposes. In this document only the size and the location of this object is defined.

OBJECT DESCRIPTION

INDEX	1002h
Name	manufacturer status register
Object Code	VAR
Data Type	UNSIGNED32
Category	Optional

ENTRY DESCRIPTION

Access	ro
PDO Mapping	Optional
Value Range	UNSIGNED32
Default Value	No

Object 1003h: Pre-defined Error Field

The object at index 1003h holds the errors that have occurred on the device and have been signaled via the Emergency Object. In doing so it provides an error history.

1. The entry at sub-index 0 contains the number of actual errors that are recorded in the array starting at sub-index 1.
2. Every new error is stored at sub-index 1, the older ones move down the list.
3. Writing a „0“ to sub-index 0 deletes the entire error history (empties the array). Values higher than 0 are not allowed to write. This have to lead to an abort message (error code: 0609 0030h).
4. The error numbers are of type UNSIGNED32 (see Table 7-18) and are composed of a 16 bit error code and a 16 bit additional error information field which is manufacturer specific. The error code is contained in the lower 2 bytes (LSB) and the additional information is included in the upper 2 bytes (MSB). If this object is supported it must consist of two entries at least. The length entry on sub-index 0h and at least one error entry at sub-index 1H.

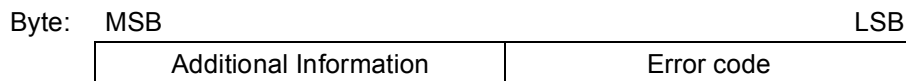

Figure 53: Structure of the pre-defined error field

OBJECT DESCRIPTION

INDEX	1003h
Name	pre-defined error field
Object Code	ARRAY
Data Type	UNSIGNED32
Category	Optional

ENTRY DESCRIPTION

Sub-Index	0h
Description	number of errors
Entry Category	Mandatory
Access	rw
PDO Mapping	No
Value Range	0 - 254
Default Value	0

Sub-Index	1h
Description	standard error field
Entry Category	Optional
Access	ro
PDO Mapping	No
Value Range	UNSIGNED32
Default Value	No

Sub-Index	2h - FEh
Description	standard error field
Entry Category	Optional
Access	ro
PDO Mapping	No
Value Range	UNSIGNED32
Default Value	No

Object 1005h: COB-ID SYNC message

Index 1005h defines the COB-ID of the Synchronisation Object (SYNC). Further, it defines whether the device generates the SYNC. The structure of this object is shown in Figure 54 and Table 49.

		UNSIGNED32				
		MSB			LSB	
bits		31	30	29	28-11	10-0
11-bit-ID	X	0/1	0		0 0	11-bit Identifier
29-bit-ID	X	0/1	1		29-bit Identifier	

Figure 54: Structure of SYNC COB-ID entry

Table 49: Description of SYNC COB-ID entry

bit number	value	meaning
31 (MSB)	X	do not care
30	0	Device does not generate SYNC message
	1	Device generates SYNC message
29	0	11-bit ID (CAN 2.0A)
	1	29-bit ID (CAN 2.0B)
28 – 11	0	if bit 29=0
	X	if bit 29=1: bits 28-11 of 29-bit-SYNC-COB-ID
10-0 (LSB)	X	bits 10-0 of SYNC-COB-ID

Bits 29, 30 may be static (not changeable). If a device is not able to generate SYNC messages, an attempt to set bit 30 is responded with an abort message (abort code: 0609 0030h). Devices supporting the standard CAN frame type only either ignore attempts to change bit 29 or respond with an abort message (abort code: 0609 0030h). The first transmission of SYNC object starts within 1 sync cycle after setting Bit 30 to 1. It is not allowed to change Bit 0-29, while the objects exists (Bit 30=1).

OBJECT DESCRIPTION

INDEX	1005h
Name	COB-ID SYNC
Object Code	VAR
Data Type	UNSIGNED32
Category	Conditional; Mandatory, if PDO communication on a synchronous base is supported

ENTRY DESCRIPTION

Access	rw
PDO Mapping	No
Value Range	UNSIGNED32
Default Value	80h or 8000 0080h

Object 1006h: Communication Cycle Period

This object defines the communication cycle period in μs . This period defines the SYNC interval. It is 0 if not used. If the communication cycle period on sync producer is changed to a new value unequal 0 the transmission of sync object resumes within 1 sync cycle of the new value.

OBJECT DESCRIPTION

INDEX	1006h
Name	communication cycle period
Object Code	VAR
Data Type	UNSIGNED32
Category	Conditional; Mandatory for Sync producers

ENTRY DESCRIPTION

Access	rw
PDO Mapping	No
Value Range	UNSIGNED32
Default Value	0

Object 1007h: Synchronous Window Length

Contains the length of the time window for synchronous PDOs in μs . It is 0 if not used.

OBJECT DESCRIPTION

INDEX	1007h
Name	synchronous window length
Object Code	VAR
Data Type	UNSIGNED32
Category	Optional

ENTRY DESCRIPTION

Access	rw
PDO Mapping	No
Value Range	UNSIGNED32
Default Value	0

Object 1008h: Manufacturer Device Name

Contains the manufacturer device name.

OBJECT DESCRIPTION

INDEX	1008h
Name	manufacturer device name
Object Code	VAR
Data Type	Visible String
Category	Optional

ENTRY DESCRIPTION

Access	const
PDO Mapping	No
Value Range	No
Default Value	No

Object 1009h: Manufacturer Hardware Version

Contains the manufacturer hardware version description.

OBJECT DESCRIPTION

INDEX	1009h
Name	manufacturer hardware version
Object Code	VAR
Data Type	Visible String
Category	Optional

ENTRY DESCRIPTION

Access	const
PDO Mapping	No
Value Range	No
Default Value	No

Object 100Ah: Manufacturer Software Version

Contains the manufacturer software version description.

OBJECT DESCRIPTION

INDEX	100Ah
Name	manufacturer software version
Object Code	VAR
Data Type	Visible String
Category	Optional

ENTRY DESCRIPTION

Access	const
PDO Mapping	No
Value Range	No
Default Value	No

Object 100Ch: Guard Time

The objects at index 100Ch and 100Dh include the guard time in milliseconds and the life time factor. The life time factor multiplied with the guard time gives the life time for the Life Guarding Protocol. It is 0 if not used.

OBJECT DESCRIPTION

INDEX	100Ch
Name	guard time
Object Code	VAR
Data Type	UNSIGNED16
Category	Conditional; Mandatory, if heartbeat is not supported

ENTRY DESCRIPTION

Access	rw; ro, if life guarding is not supported
PDO Mapping	No
Value Range	UNSIGNED16
Default Value	0

Object 100Dh: Life Time Factor

The life time factor multiplied with the guard time gives the life time for the node guarding protocol. It is 0 if not used.

OBJECT DESCRIPTION

INDEX	100Dh
Name	life time factor
Object Code	VAR
Data Type	UNSIGNED8
Category	Conditional; Mandatory, if heartbeat is not supported

ENTRY DESCRIPTION

Access	rw; ro, if life guarding is not supported
PDO Mapping	No
Value Range	UNSIGNED8
Default Value	0

Object 1010h: Store parameters

This object supports the saving of parameters in non volatile memory. By read access the device provides information about its saving capabilities. Several parameter groups are distinguished: Sub-Index 0 contains the largest Sub-Index that is supported.

Sub-Index 1 refers to all parameters that can be stored on the device.

Sub-Index 2 refers to communication related parameters (Index 1000h - 1FFFh manufacturer specific communication parameters).

Sub-Index 3 refers to application related parameters (Index 6000h - 9FFFh manufacturer specific application parameters).

At Sub-Index 4 - 127 manufacturers may store their choice of parameters individually.

Sub-Index 128 - 254 are reserved for future use.

In order to avoid storage of parameters by mistake, storage is only executed when a specific signature is written to the appropriate Sub-Index. The signature is „save“.

Signature	MSB		LSB	
ISO 8859 ("ASCII")	e	v	a	s
hex	65h	76h	61h	73h

Figure 55: Storage write access signature

On reception of the correct signature in the appropriate sub-index the device stores the parameter and then confirms the SDO transmission (initiate download response). If the storing failed, the device responds with an Abort SDO Transfer (abort code: 0606 0000h).

If a wrong signature is written, the device refuses to store and responds with Abort SDO Transfer (abort code: 0800 002xh).

On read access to the appropriate Sub-Index the device provides information about its storage functionality with the following format:

	UNSIGNED32		
	MSB		LSB
bits	31-2	1	0
	reserved (=0)	0/1	0/1

Figure 56: Storage read access structure

Table 50: Structure of read access

bit number	value	meaning
31-2	0	reserved (=0)
1	0	Device does not save parameters autonomously
	1	Device saves parameters autonomously
0	0	Device does not save parameters on command
	1	Device saves parameters on command

Autonomous saving means that a device stores the storable parameters in a non-volatile manner without user request.

OBJECT DESCRIPTION

INDEX	1010h
Name	store parameters
Object Code	ARRAY
Data Type	UNSIGNED32
Category	Optional

ENTRY DESCRIPTION

Sub-Index	0h
Description	largest subindex supported
Entry Category	Mandatory
Access	ro
PDO Mapping	No
Value Range	1h – 7Fh
Default Value	No

Sub-Index	1h
Description	save all parameters
Entry Category	Mandatory
Access	rw
PDO Mapping	No
Value Range	UNSIGNED32 (Figure 55 for write access; Figure 56 for read access)
Default Value	No

Sub-Index	2h
Description	save communication parameters
Entry Category	Optional
Access	rw
PDO Mapping	No
Value Range	UNSIGNED32 (Figure 55 for write access; Figure 56 for read access)
Default Value	No

Sub-Index	3h
Description	save application parameters
Entry Category	Optional
Access	rw
PDO Mapping	No
Value Range	UNSIGNED32 (Figure 55 for write access; Figure 56 for read access)
Default Value	No

Sub-Index	4h - 7Fh
Description	save manufacturer defined parameters
Entry Category	Optional
Access	rw
PDO Mapping	No
Value Range	UNSIGNED32 (Figure 55 for write access; Figure 56 for read access)
Default Value	No

Object 1011h: Restore default parameters

With this object the default values of parameters according to the communication or device profile are restored. By read access the device provides information about its capabilities to restore these values. Several parameter groups are distinguished:

Sub-Index 0 contains the largest Sub-Index that is supported.
Sub-Index 1 refers to all parameters that can be restored.

Sub-Index 2 refers to communication related parameters (Index 1000h - 1FFFh manufacturer specific communication parameters).

Sub-Index 3 refers to application related parameters (Index 6000h - 9FFFh manufacturer specific application parameters).

At Sub-Index 4 - 127 manufacturers may restore their individual choice of parameters.

Sub-Index 128 - 254 are reserved for future use.

In order to avoid the restoring of default parameters by mistake, restoring is only executed when a specific signature is written to the appropriate sub-index. The signature is „load“.

Signature	MSB			LSB
ASCII	d	a	o	l
hex	64h	61h	6Fh	6Ch

Figure 57: Restoring write access signature

On reception of the correct signature in the appropriate sub-index the device restores the default parameters and then confirms the SDO transmission (initiate download response). If the restoring failed, the device responds with an Abort SDO Transfer (abort code: 0606 0000h). If a wrong signature is written, the device refuses to restore the defaults and responds with an Abort SDO Transfer (abort code: 0800 002xh).

The default values are set valid after the device is reset (reset node for sub-index 1h – 7Fh, reset communication for sub-index 2h) or power cycled.

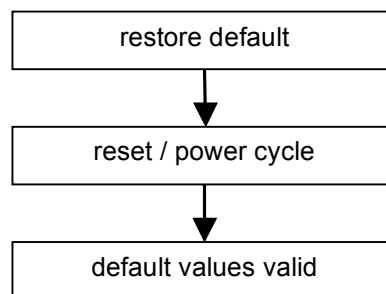

Figure 58: restore procedure

On read access to the appropriate sub-index the device provides information about its default parameter restoring capability with the following format:

UNSIGNED32		
	MSB	LSB
bits	31-1	0
	reserved (=0)	0/1

Figure 59: Restoring default values read access structure

Table 51: Structure of restore read access

bit number	value	meaning
31-1	0	<i>reserved (=0)</i>
0	0	Device does not restore default parameters
	1	Device restores parameters

OBJECT DESCRIPTION

INDEX	1011h
Name	restore default parameters
Object Code	ARRAY
Data Type	UNSIGNED32
Category	Optional

ENTRY DESCRIPTION

Sub-Index	0h
Description	largest subindex supported
Entry Category	Mandatory
Access	ro
PDO Mapping	No
Value Range	1h – 7Fh
Default Value	No

Sub-Index	1h
Description	restore all default parameters
Entry Category	Mandatory
Access	rw
PDO Mapping	No
Value Range	UNSIGNED32 (Figure 57)
Default Value	No

Sub-Index	2h
Description	restore communication default parameters
Entry Category	Optional
Access	rw
PDO Mapping	No
Value Range	UNSIGNED32 (Figure 57)
Default Value	No

Sub-Index	3h
Description	restore application default parameters
Entry Category	Optional
Access	rw
PDO Mapping	No
Value Range	UNSIGNED32 (Figure 57)
Default Value	No

Sub-Index	4h - 7Fh
Description	restore manufacturer defined default parameters
Entry Category	Optional
PDO Mapping	No
Value Range	UNSIGNED32 (Figure 57)

Object 1012h: COB-ID Time Stamp Object

Index 1012h defines the COB-ID of the Time-Stamp Object (TIME). Further, it defines whether the device consumes the TIME or whether the device generates the TIME. The structure of this object is shown in Figure 60 and Table 52.

		UNSIGNED32						
		MSB			LSB			
bits		31	30	29	28-11	10-0		
11-bit-ID		0/1	0/1	0	0 0 0 0 0 0 0 0 0 0 0 0 0 0 0 0 0 0		11-bit Identifier	
29-bit-ID		0/1	0/1	1	29-bit Identifier			

Figure 60: Structure of TIME COB-ID entry

Table 52: Description of TIME COB-ID entry

bit number	value	meaning
31 (MSB)	0	Device does not consume TIME message
	1	Device consumes TIME message
30	0	Device does not produce TIME message
	1	Device produces TIME message
29	0	11-bit ID (CAN 2.0A)
	1	29-bit ID (CAN 2.0B)
28 – 11	0	if bit 29=0
	X	if bit 29=1: bits 28-11 of 29-bit-TIME-COB-ID
10-0 (LSB)	X	bits 10-0 of TIME-COB-ID

Bits 29, 30 may be static (not changeable). If a device is not able to generate TIME messages, an attempt to set bit 30 is responded with an abort message (abort code: 0609 0030h). Devices supporting the standard CAN frame type only, an attempt to set bit 29 is responded with an abort message (abort code: 0609 0030h). It is not allowed to change Bits 0-29, while the object exists (Bit 30=1).

OBJECT DESCRIPTION

INDEX	1012h
Name	COB-ID time stamp message
Object Code	VAR
Data Type	UNSIGNED32
Category	Optional

ENTRY DESCRIPTION

Access	rw
PDO Mapping	No
Value Range	UNSIGNED32
Default Value	100h

Object 1013h: High Resolution Time Stamp

This object contains a time stamp with a resolution of 1 μ s (see 9.3.2). It can be mapped into a PDO in order to define a high resolution time stamp message. (Note that the data type of the standard time stamp message (TIME) is fixed). Further application specific use is encouraged.

OBJECT DESCRIPTION

INDEX	1013h
Name	high resolution time stamp
Object Code	VAR
Data Type	UNSIGNED32
Category	Optional

ENTRY DESCRIPTION

Access	rw
PDO Mapping	Optional
Value Range	UNSIGNED32
Default Value	0

Object 1014h: COB-ID Emergency Object

Index 1014h defines the COB-ID of the Emergency Object (EMCY). The structure of this object is shown in Figure 61.

		UNSIGNED32				
		MSB			LSB	
bits		31	30	29	28-11	10-0
11-bit-ID	0/1	0	0	0	0 0	11-bit Identifier
29-bit-ID	0/1	0	1		29-bit Identifier	

Figure 61: Structure of the EMCY Identifier entry

Table 53: Description of EMCY COB-ID entry

bit number	value	Meaning
31 (MSB)	0	EMCY exists / is valid
	1	EMCY does not exist / is not valid
30	0	reserved (always 0)
29	0	11-bit ID (CAN 2.0A)
	1	29-bit ID (CAN 2.0B)
28 - 11	0	if bit 29=0
	X	if bit 29=1: bits 28-11 of 29-bit-COB-ID
10-0 (LSB)	X	bits 10-0 of COB-ID

Devices supporting the standard CAN frame type only, an attempt to set bit 29 is responded with an abort message (abort code: 0609 0030h). It is not allowed to change Bits 0-29, while the object exists (Bit 31=0).

OBJECT DESCRIPTION

INDEX	1014h
Name	COB-ID Emergency message
Object Code	VAR
Data Type	UNSIGNED32
Category	Conditional; Mandatory, if Emergency is supported

ENTRY DESCRIPTION

Access	ro; optional rw
PDO Mapping	No
Value Range	UNSIGNED32
Default Value	80h + Node-ID

Object 1015h: Inhibit Time EMCY

The inhibit time for the EMCY message can be adjusted via this entry. If this entry exists it must be writable in the object dictionary. The time has to be a multiple of 100µs.

OBJECT DESCRIPTION

INDEX	1015h
Name	Inhibit Time EMCY
Object Code	VAR
Data Type	UNSIGNED16
Category	Optional

ENTRY DESCRIPTION

Access	rw
PDO Mapping	No
Value Range	UNSIGNED16
Default Value	0

Object 1016h: Consumer Heartbeat Time

The consumer heartbeat time defines the expected heartbeat cycle time and thus has to be higher than the corresponding producer heartbeat time configured on the device producing this heartbeat. Monitoring starts after the reception of the first heartbeat. If the consumer heartbeat time is 0 the corresponding entry is not used. The time has to be a multiple of 1ms.

	MSB		LSB
Bits	31-24	23-16	15-0
Value	reserved (value: 00h)	Node-ID	heartbeat time
Encoded as	-	UNSIGNED8	UNSIGNED16

Figure 62: Structure of Consumer Heartbeat Time entry

At an attempt to configure several consumer heartbeat times unequal 0 for the same Node-ID the device aborts the SDO download with abort code 0604 0043h

OBJECT DESCRIPTION

INDEX	1016h
Name	Consumer Heartbeat Time
Object Code	ARRAY
Data Type	UNSIGNED32
Category	Optional

ENTRY DESCRIPTION

Sub-Index	0h
Description	number entries
Entry Category	Mandatory
Access	ro
PDO Mapping	No
Value Range	1 – 127
Default Value	No

Sub-Index	1h
Description	Consumer Heartbeat Time
Entry Category	Mandatory
Access	rw
PDO Mapping	No
Value Range	UNSIGNED32 (Figure 62)
Default Value	0

Sub-Index	2h – 7Fh
Description	Consumer Heartbeat Time
Entry Category	Optional
Access	rw
PDO Mapping	No
Value Range	UNSIGNED32 (Figure 62)
Default Value	No

Object 1017h: Producer Heartbeat Time

The producer heartbeat time defines the cycle time of the heartbeat. The producer heartbeat time is 0 if it not used. The time has to be a multiple of 1ms.

OBJECT DESCRIPTION

INDEX	1017h
Name	Producer Heartbeat Time
Object Code	VAR
Data Type	UNSIGNED16
Category	Conditional; Mandatory if guarding not supported

ENTRY DESCRIPTION

Access	rw
PDO Mapping	No
Value Range	UNSIGNED16
Default Value	0

Object 1018h: Identity Object

The object at index 1018h contains general information about the device.

The Vendor ID (sub-index 1h) contains a unique value allocated to each manufacturer.

The manufacturer-specific Product code (sub-index 2h) identifies a specific device version.

The manufacturer-specific Revision number (sub-index 3h) consists of a major revision number and a minor revision number. The major revision number identifies a specific CANopen behaviour. If the CANopen functionality is expanded, the major revision has to be incremented. The minor revision number identifies different versions with the same CANopen behaviour.

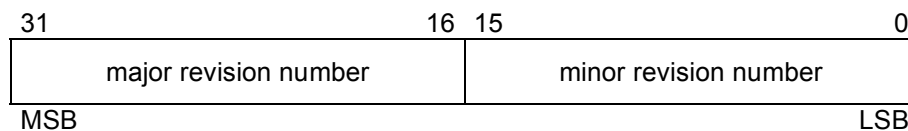

Figure 63: Structure of Revision number

The manufacturer-specific Serial number (sub-index 4h) identifies a specific device.

OBJECT DESCRIPTION

INDEX	1018h
Name	Identity Object
Object Code	RECORD
Data Type	Identity
Category	Mandatory

ENTRY DESCRIPTION

Sub-Index	0h
Description	number of entries
Entry Category	Mandatory
Access	ro
PDO Mapping	No
Value Range	1 .. 4
Default Value	No

Sub-Index	1h
Description	Vendor ID
Entry Category	Mandatory
Access	ro
PDO Mapping	No
Value Range	UNSIGNED32
Default Value	No

Sub-Index	2h
Description	Product code
Entry Category	Optional
Access	ro
PDO Mapping	No
Value Range	UNSIGNED32
Default Value	No

Sub-Index	3h
Description	Revision number
Entry Category	Optional
Access	ro
PDO Mapping	No
Value Range	UNSIGNED32
Default Value	No

Sub-Index	4h
Description	Serial number
Entry Category	Optional
Access	ro
PDO Mapping	No
Value Range	UNSIGNED32
Default Value	No

Object 1200h - 127Fh: Server SDO Parameter

In order to describe the SDOs used on a device the data type SDO Parameter is introduced. The data type has the index 22h in the Object Dictionary. The structure is described in 9.5.4.

The number of supported entries in the SDO object record is specified at sub-index 0h. The values at 1h and 2h specify the COB-ID for this SDO. Sub-index 3 gives the server of the SDO in case the record describes an SDO for which the device is client and gives the client of the SDO if the record describes an SDO for which the device is server.

UNSIGNED32					
MSB			LSB		
bits	31	30	29	28-11	10-0
11-bit-ID	0/1	0	0	0 0	11-bit Identifier
29-bit-ID	0/1	0	1	29-bit Identifier	

Figure 64: Structure of SDO COB-ID entry

Table 54: Description of SDO COB-ID entry

bit number	value	Meaning
31 (MSB)	0	SDO exists / is valid
	1	SDO does not exist / is not valid
30	0	reserved (always 0)
29	0	11-bit ID (CAN 2.0A)
	1	29-bit ID (CAN 2.0B)
28 - 11	0	if bit 29=0
	X	if bit 29=1: bits 28-11 of 29-bit-COB-ID
10-0 (LSB)	X	bits 10-0 of COB-ID

An SDO is only valid if both SDO-valid-bits are 0. Devices supporting the standard CAN frame type only, an attempt to set bit 29 is responded with an abort message (abort code: 0609 0030h). These objects contain the parameters for the SDOs for which the device is the server. If a device handles more than one server SDO the default SDO must be located at index 1200h as the first server SDO. This entry is read only². All additional server SDOs are invalid by default (invalid bit - see Table 54), there description is located at subsequent indices. It is not allowed to change the COB-ID while the SDO exists.

The description of the Client of the SDO (sub-index 3h) is optional. It is not available for the default SDO (no Sub-index 3h at Index 1200h), as this entry is read only.

OBJECT DESCRIPTION

INDEX	1200h - 127Fh
Name	Server SDO parameter
Object Code	RECORD
Data Type	SDO Parameter
Category	Conditional Index 1200h: Optional Index 1201h - 127Fh: Mandatory for each additionally supported server SDO

² It has to be ensured that the COB-IDs of the default SDO can not be manipulated by writing to the Object Dictionary.

ENTRY DESCRIPTION

Sub-Index	0h
Description	number of entries
Entry Category	Mandatory
Access	ro
PDO Mapping	No
Value Range	Index 1200h: 2 Index 1201h – 127Fh: 2 - 3
Default Value	No

Sub-Index	1h
Description	COB-ID Client->Server (rx)
Entry Category	Mandatory
Access	Index 1200h: ro, Index 1201h-127Fh: rw
PDO Mapping	No
Value Range	UNSIGNED32 (Table 54)
Default Value	Index 1200h: 600h+Node-ID, Index 1201h-127Fh: disabled

Sub-Index	2h
Description	COB-ID Server -> Client (tx)
Entry Category	Mandatory
Access	Index 1200h: ro Index 1201-127Fh: rw
PDO Mapping	No
Value Range	UNSIGNED32 (Table 54)
Default Value	Index 1200h: 580h+Node-ID, Index 1201h-127Fh: disabled

Sub-Index	3h
Description	Node-ID of the SDO client
Entry Category	Optional
Access	rw
PDO Mapping	No
Value Range	1h – 7Fh
Default Value	No

Object 1280h - 12FFh: Client SDO Parameter

These objects contain the parameters for the SDOs for which the device is the client. If the entry is supported, all sub-indices must be available. Starting at index 1280h and subsequent indices. The entries are described at the Server SDO Parameter. All client SDOs are invalid by default (invalid bit – see Table 54).

OBJECT DESCRIPTION

INDEX	1280h - 12FFh
Name	Client SDO parameter
Object Code	RECORD
Data Type	SDO Parameter
Category	Conditional; Mandatory for each supported client SDO

ENTRY DESCRIPTION

Sub-Index	0h
Description	number of entries
Entry Category	Mandatory
Access	ro
PDO Mapping	No
Value Range	3
Default Value	3

Sub-Index	1h
Description	COB-ID Client->Server (tx)
Entry Category	Mandatory
Access	rw
PDO Mapping	No
Value Range	UNSIGNED32 (Table 54)
Default Value	disabled

Sub-Index	2h
Description	COB-ID Server -> Client (rx)
Entry Category	Mandatory
Access	rw
PDO Mapping	No
Value Range	UNSIGNED32 (Table 54)
Default Value	disabled

Sub-Index	3h
Description	Node-ID of the SDO server
Entry Category	Mandatory
Access	rw
PDO Mapping	No
Value Range	1h – 7Fh
Default Value	No

Object 1400h - 15FFh: Receive PDO Communication Parameter

Contains the communication parameters for the PDOs the device is able to receive. The type of the PDO communication parameter (20h) is described in 9.5.4. The sub-index 0h contains the number of valid entries within the communication record. Its value is at least 2. If inhibit time supported the value is 3. At sub-index 1h resides the COB-ID of the PDO. This entry has been defined as UNSIGNED32 in order to cater for 11-bit CAN Identifiers (CAN 2.0A) as well as for 29-bit CAN identifiers (CAN 2.0B). The entry has to be interpreted as defined in Figure 65 and Table 55.

		UNSIGNED32				
		MSB			LSB	
bits		31	30	29	28-11	10-0
11-bit-ID	0/1	0/1	0	0 0		11-bit Identifier
29-bit-ID	0/1	0/1	1	29-bit Identifier		

Figure 65: Structure of PDO COB-ID entry

Table 55: Description of PDO COB-ID entry

bit number	value	meaning
31 (MSB)	0	PDO exists / is valid
	1	PDO does not exist / is not valid
30	0	RTR allowed on this PDO
	1	no RTR allowed on this PDO
29	0	11-bit ID (CAN 2.0A)
	1	29-bit ID (CAN 2.0B)
28 – 11	0	if bit 29=0
	X	if bit 29=1: bits 28-11 of 29-bit-COB-ID
10-0 (LSB)	X	bits 10-0 of COB-ID

The PDO valid/not valid allows to select which PDOs are used in the operational state. There may be PDOs fully configured (e.g. by default) but not used, and therefore set to "not valid" (deleted). The feature is necessary for devices supporting more than 4 RPDOs or 4 TPDOs, because each device has only default identifiers for the first four RPDOs/TPDOs. Devices supporting the standard CAN frame type only or do not support Remote Frames, an attempt to set bit 29 to 1 or bit 30 to 0 is responded with an abort message (abort code: 0609 0030h).

It is not allowed to change bit 0-29 while the PDO exists (Bit 31=0).

The transmission type (sub-index 2) defines the transmission/reception character of the PDO (see 9.2.1.1). Table 56 describes the usage of this entry. On an attempt to change the value of the transmission type to a value that is not supported by the device an abort message (abort code: 0609 0030h) is generated.

Table 56: Description of transmission type

transmission type	PDO transmission				
	cyclic	acyclic	synchronous	asynchronous	RTR only
0		X	X		
1-240	X		X		
241-251	- reserved -				
252			X		X
253				X	X
254				X	
255				X	

Synchronous (transmission types 0-240 and 252) means that the transmission of the PDO shall be related to the SYNC object as described in 9.3. Preferably the devices use the SYNC as a trigger to output or actuate based on the previous synchronous Receive PDO respectively to update the data transmitted at the following synchronous Transmit PDO. Details of this mechanism depend on the device type and are defined in the device profile if applicable.

Asynchronous means that the transmission of the PDO is not related to the SYNC object.

A transmission type of zero means that the message shall be transmitted synchronously with the SYNC object but not periodically.

A value between 1 and 240 means that the PDO is transferred synchronously and cyclically. The transmission type indicating the number of SYNC which are necessary to trigger PDO transmissions. Receive PDOs are always triggered by the following SYNC upon reception of data independent of the transmission types 0 - 240.

The transmission types 252 and 253 mean that the PDO is only transmitted on remote transmission request. At transmission type 252, the data is updated (but not sent) immediately after reception of the SYNC object. At transmission type 253 the data is updated at the reception of the remote transmission request (hardware and software restrictions may apply). These value are only possible for TPDOs.

For TPDOs transmission type 254 means, the application event is manufacturer specific (manufacturer specific part of the Object Dictionary), transmission type 255 means, the application event is defined in the device profile. RPDOs with that type trigger the update of the mapped data with the reception.

Sub-index 3h contains the inhibit time. This time is a minimum interval for PDO transmission. The value is defined as multiple of 100µs. It is not allowed to change the value while the PDO exists (Bit 31 of sub-index 1 is 0).

Sub-index 4h is reserved. It does not have to be implemented, in this case read or write access leads to Abort SDO Transfer (abort code: 0609 0011h).

In mode 254/255 additionally an event time can be used for TPDO. If an event timer exists for a TPDO (value not equal to 0) the elapsed timer is considered to be an event. The event timer elapses as multiple of 1 ms of the entry in sub-index 5h of the TPDO. This event will cause the transmission of this TPDO in addition to otherwise defined events. The occurrence of the events set the timer.

Independent of the transmission type the RPDO event timer is used recognize the expiration of the RPDO.

OBJECT DESCRIPTION

INDEX	1400h - 15FFh
Name	receive PDO parameter
Object Code	RECORD
Data Type	PDO CommPar
Category	Conditional; Mandatory for each supported PDO

ENTRY DESCRIPTION

Sub-Index	0h
Description	largest sub-index supported
Entry Category	Mandatory
Access	ro
PDO Mapping	No
Value Range	2 – 5

Sub-Index	1h
Description	COB-ID used by PDO
Entry Category	Mandatory
Access	ro; rw if variable COB-ID is supported
PDO Mapping	No
Value Range	UNSIGNED32 (Table 55)
Default Value	Index 1400h: 200h + Node-ID, Index 1401h: 300h + Node-ID, Index 1402h: 400h + Node-ID, Index 1403h: 500h + Node-ID, Index 1404h – 15FFh: disabled

Sub-Index	2h
Description	transmission type
Entry Category	Mandatory
Access	ro; rw if variable transmission type is supported
PDO Mapping	No
Value Range	UNSIGNED8 (Table 56)
Default Value	(Device Profile dependent)

Sub-Index	3h
Description	inhibit time (not used for RPDO)
Entry Category	Optional
Access	rw
PDO Mapping	No
Value Range	UNSIGNED16
Default Value	No

Sub-Index	4h
Description	compatibility entry
Entry Category	Optional
Access	rw
PDO Mapping	No
Value Range	UNSIGNED8
Default Value	No

Sub-Index	5h
Description	event timer
Entry Category	Optional (not used for RPDO)
Access	rw
PDO Mapping	No
Value Range	0 – not used UNSIGNED16
Default Value	No

Object 1600h - 17FFh: Receive PDO Mapping Parameter

Contains the mapping for the PDOs the device is able to receive. The type of the PDO mapping parameter (21h) is described in 9.5.4. The sub-index 0h contains the number of valid entries within the mapping record. This number of entries is also the number of the application variables which shall be transmitted/received with the corresponding PDO. The sub-indices from 1h to number of entries contain the information about the mapped application variables. These entries describe the PDO contents by their index, sub-index and length (Figure 66). All three values are hexadecimal coded. The length entry contains the length of the object in bit (1..40h). This parameter can be used to verify the overall mapping length. It is mandatory.

The structure of the entries from sub-index 1h – 40h is as follows:

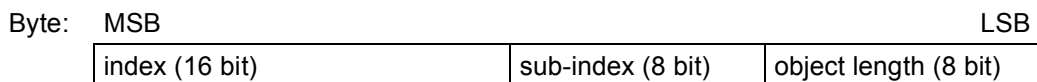

Figure 66: Structure of PDO Mapping Entry

If the change of the PDO mapping cannot be executed (e.g. the PDO length is exceeded or the SDO client attempts to map an object that cannot be mapped) the device responds with an Abort SDO Transfer Service.

Subindex 0 determines the valid number of objects that have been mapped. For changing the PDO mapping first the PDO has to be deleted, the sub-index 0 must be set to 0 (mapping is deactivated). Then the objects can be remapped. When a new object is mapped by writing a subindex between 1 and 64, the device may check whether the object specified by index / sub-index exists. If the object does not exist or the object cannot be mapped, the SDO transfer must be aborted with the Abort SDO Transfer Service with one of the abort codes 0602 0000h or 0604 0041h.

After all objects are mapped subindex 0 is set to the valid number of mapped objects. Finally the PDO will be created by writing to its communication parameter COB-ID. When subindex 0 is set to a value >0 the device may validate the new PDO mapping before transmitting the response of the SDO service. If an error is detected the device has to transmit the Abort SDO Transfer Service with one of the abort codes 0602 0000h, 0604 0041h or 0604 0042h.

When subindex 0 is read the actual number of valid mapped objects is returned.

If data types (Index 1h-7h) are mapped they serve as „dummy entries“. The corresponding data in the PDO is not evaluated by the device. This optional feature is useful e.g. to transmit data to several devices using one PDO, each device only utilising a part of the PDO. It is not possible to create a dummy mapping for a TPDO.

A device that supports dynamic mapping of PDOs must support this during the state PRE-OPERATIONAL state. If dynamic mapping during the state OPERATIONAL is supported, the SDO client is responsible for data consistency.

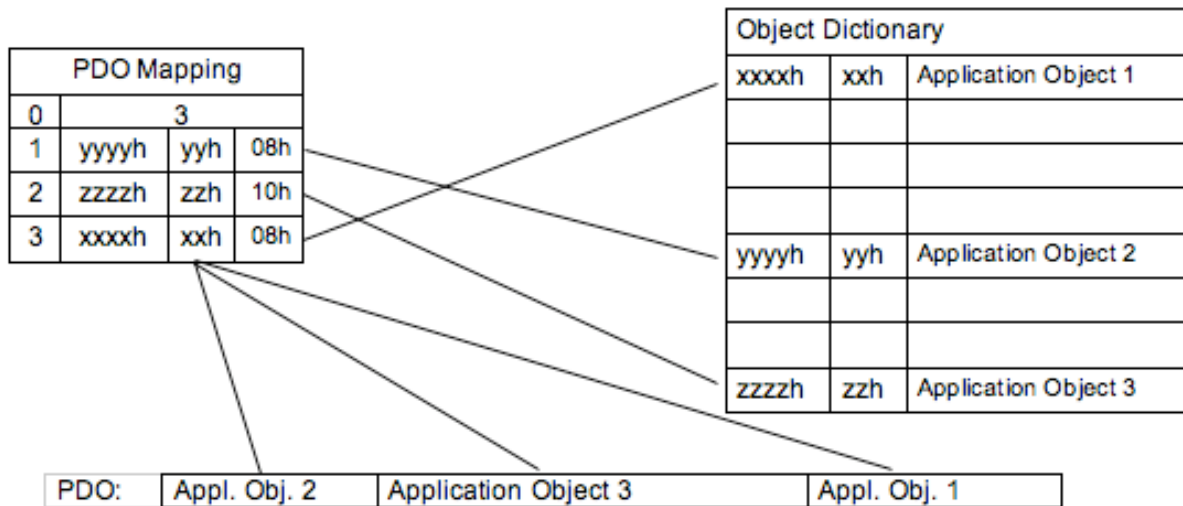

Figure 67: Principle of PDO mapping

OBJECT DESCRIPTION

INDEX	1600h – 17FFh
Name	receive PDO mapping
Object Code	RECORD
Data Type	PDO Mapping
Category	Conditional; Mandatory for each supported PDO

ENTRY DESCRIPTION

Sub-Index	0h
Description	number of mapped application objects in PDO
Entry Category	Mandatory
Access	ro; rw if dynamic mapping is supported
PDO Mapping	No
Value Range	0: deactivated 1 – 64: activated
Default Value	(device profile dependent)

Sub-Index	1h – 40h
Description	PDO mapping for the nth application object to be mapped
Entry Category	Conditional depends on number and size of object be mapped
Access	rw
PDO Mapping	No
Value Range	UNSIGNED32
Default Value	(device profile dependent)

Object 1800h - 19FFh: Transmit PDO Communication Parameter

Contains the communication parameters for the PDOs the device is able to transmit. The type of the PDO communication parameter (20h) is described in 9.5.4. A detailed description of the entries is done in the section for the Receive PDO Communication Parameter (1400h – 15FFh).

OBJECT DESCRIPTION

INDEX	1800h - 19FFh
Name	transmit PDO parameter
Object Code	RECORD
Data Type	PDO CommPar
Category	Conditional; Mandatory for each supported PDO

ENTRY DESCRIPTION

Sub-Index	0h
Description	largest sub-index supported
Entry Category	Mandatory
Access	ro
PDO Mapping	No
Value Range	2 – 5

Sub-Index	1h
Description	COB-ID used by PDO
Entry Category	Mandatory
Access	ro; rw if COB-ID can be configured
PDO Mapping	No
Value Range	UNSIGNED32 (Figure 65)
Default Value	Index 1800h: 180h + Node-ID, Index 1801h: 280h + Node-ID, Index 1802h: 380h + Node-ID, Index 1803h: 480h + Node-ID, Index 1804h - 18FFh: disabled

Sub-Index	2h
Description	transmission type
Entry Category	Mandatory
Access	ro; rw if transmission type can be changed
PDO Mapping	No
Value Range	UNSIGNED8 (Table 55)
Default Value	(device profile dependent)

Sub-Index	3h
Description	inhibit time
Entry Category	Optional
Access	rw
PDO Mapping	No
Value Range	UNSIGNED16
Default Value	(device profile dependent)

Sub-Index	4h
Description	reserved
Entry Category	Optional
Access	rw
PDO Mapping	No
Value Range	UNSIGNED8
Default Value	No

Sub-Index	5h
Description	event timer
Entry Category	Optional
Access	rw
PDO Mapping	No
Value Range	0 – not used UNSIGNED16
Default Value	(device profile dependent)

Object 1A00h - 1BFFh: Transmit PDO Mapping Parameter

Contains the mapping for the PDOs the device is able to transmit. The type of the PDO mapping parameter (21h) is described in 9.5.4. A detailed description of the entries is done in the section for the Receive PDO Mapping Parameter (1600h – 17FFh).

OBJECT DESCRIPTION

INDEX	1A00h - 1BFFh
Name	transmit PDO mapping
Object Code	RECORD
Data Type	PDO Mapping
Category	Conditional; Mandatory for each supported PDO

ENTRY DESCRIPTION

Sub-Index	0h
Description	number of mapped application objects in PDO
Entry Category	Mandatory
Access	ro; rw if dynamic mapping is supported
PDO Mapping	No
Value Range	0: deactivated 1 – 64: activated
Default Value	(device profile dependent)

Sub-Index	1h – 40h
Description	PDO mapping for the n-th application object to be mapped
Entry Category	Conditional; depends on number and size of objects to be mapped
Access	rw
PDO Mapping	No
Value Range	UNSIGNED32
Default Value	(device profile dependent)

10 IMPLEMENTATION RECOMMENDATIONS

When implementing the protocols, the following rules should be obeyed to guarantee interoperability. These rules deal with the following implementation aspects:

Invalid COB's

A COB is invalid if it has a COB-ID that is used by the specified protocols, but it contains invalid parameter values according to the protocol specification. This can only be caused by errors in the lower layers or implementation errors. Invalid COB's must be handled **locally** in an implementation specific way that does not fall within the scope of this specification. As far as the protocol is concerned, an invalid COB must be ignored.

Time-out's

Since COB's may be ignored, the response of a confirmed service may never arrive. To resolve this situation, an implementation may, after a certain amount of time, indicate this to the service user (time-out). **A time-out is not a confirm of that service.** A time-out indicates that the service has not completed yet. The application must deal with this situation. Time-out values are considered to be implementation specific and do not fall within the scope of this specification. However, it is recommended that an implementation provides facilities to adjust these time-out values to the requirements of the application.

11 Annex A (normative)

Additional functionality for CANopen NMT slaves

Version 2.0.1

Date: 13 February 2002

In this normative annex, there is described the functionality for CANopen NMT slave devices that was originally specified in CiA DSP-302 Framework for programmable CANopen devices.

11.1 Additional object dictionary entries

Additional records

Index (hex)	Object (Symbolic Name)	Name
0024	DEFSTRUCT	Debugger Par
0025	DEFSTRUCT	Command Par

Additional communication objects

Index (hex)	Object (Symbolic Name)	Name	Type	Acc. ³	M/O
Device configuration					
1020	ARRAY	Verify Configuration	UNSIGNED32	rw	O
EDS storage					
1021	VAR	Store EDS	DOMAIN	rw	O
1022	VAR	Storage Format	UNSIGNED8	rw	O
OS command and prompt					
1023	RECORD	OS Command	Command Par	rw	O
1024	VAR	OS Command Mode	UNSIGNED8	wo	O
1025	RECORD	OS Debugger Interface	Debugger Par	rw	O
1026	ARRAY	OS Prompt	UNSIGNED8	rw	O
Modular devices					
1027	ARRAY	Module list	UNSIGNED16	ro	M/O*
Additional objects					
1028	ARRAY	Emergency Consumer	UNSIGNED32	rw	O
1029	ARRAY	Error Behaviour	UNSIGNED8	rw	O
Multiplexed PDO					
1FA0 - 1FCF	ARRAY	Object Scanner List	UNSIGNED32	rw	O
1FD0 - 1FFF	ARRAY	Object Dispatching List	UNSIGNED64	rw	O

*Mandatory for modular devices; otherwise optional.

³ Access type listed here may vary for certain sub-indices. See detailed object specification.

11.2 Device configuration

11.2.1 Boot-up configuration process

The parameter in object 1010h for saving the configuration of a slave is not sufficient for a CANopen Manager to determine, if the slave has recovered its last configuration after the reset, and can be immediately put to the state Operational. To allow a CANopen Manager to determine whether a slave needs to be reconfigured, the following optional object should be used:

Object 1020h: Verify Configuration

If a device supports the saving of parameters in non-volatile memory, a network configuration tool or a CANopen manager can use this object to verify the configuration after a devices reset and to check if a reconfiguration is necessary. The configuration tool shall store the date and time in that object and shall store the same values in the DCF. Now the configuration tool lets the device save its configuration by writing to index 1010h Sub-Index 1h the signature "save". After a reset the device shall restore the last configuration and the signature automatically or by request. If any other command changes boot-up configuration values, the device shall reset the object Verify Configuration to 0.

The Configuration Manager compares signature and configuration with the value from the DCF and decides if a reconfiguration is necessary or not.

OBJECT DESCRIPTION

INDEX	1020h
Name	Verify configuration
Object Code	ARRAY
Data Type	UNSIGNED32
Category	Optional

ENTRY DESCRIPTION

Sub-Index	0h
Description	number of supported entries
Entry Category	Mandatory
Access	ro
PDO Mapping	No
Value Range	2
Default Value	2

Sub-Index	1h
Description	Configuration date
Entry Category	Mandatory
Access	rw
PDO Mapping	No
Value Range	UNSIGNED32
Default Value	No

Sub-Index	2h
Description	Configuration time
Entry Category	Mandatory
Access	rw
PDO Mapping	No
Value Range	UNSIGNED32
Default Value	No

Configuration date shall contain the number of days since January 1,1984. Configuration time shall be the number of ms after midnight.

Application hint: The usage of this object allows a significant speed-up of the boot-up process. If it is used, the system integrator has to consider that a user may change a configuration value and afterwards activate the command store configuration 1010h without changing the value of 1020h. So the system integrator has to ensure a 100% consequent usage of this feature.

11.2.2 EDS storage

For some devices it may be possible to store the EDS. This has some advantages:

- The manufacturer does not have the problem of distributing the EDS via disks
- Management of different EDS versions for different software versions is less error prone, if they are stored together
- The complete network settings may be stored in the network. This makes the task of analysing or reconfiguring a network easier for tools and more transparent for the users.

The EDS may be stored in the following object:

OBJECT DESCRIPTION

INDEX	1021h
Name	Store EDS
Object Code	VAR
Data Type	DOMAIN
Category	Optional

ENTRY DESCRIPTION

Access	rw
PDO Mapping	No
Value Range	No
Default Value	No

The filename does not need to be stored since every EDS contains its own filename.

Object 1022h describes the format of the storage. This allows the usage of compressed formats.

Value	Format
0	ASCII, not compressed
1-255	reserved

The device may always store the file compressed internally. The object describes the external behaviour.

OBJECT DESCRIPTION

INDEX	1022h
Name	Stroe format
Object Code	VAR
Data Type	UNSIGNED16
Category	Conditional; Mandatory if Store EDS is supported

ENTRY DESCRIPTION

Access	rw
PDO Mapping	No
Value Range	UNSIGNED8
Default Value	No

11.3 OS command and prompt

Many operating systems of programmable devices support a console prompt. Commands may be entered by the user with a keyboard or any other user input device (e.g. PC-based software with mouse commands). In order to permit remote configuration and remote debugging of such a node, the objects "OS Command/Debugger Interface" are defined in the object dictionary. The commands are specific by the manufacturer. Two types of command usage are very common. For many PLCs, the command interpreter expects a binary data stream, the command and additional binary data such as a CRC etc. Another concept is the single character or line driven method.

Refer also to the program download description in CiA DSP-302.

11.3.1 OS command

The OS Command object may be used as a command driven interface to programmable devices. The contents of the command may be ASCII or binary and are completely manufacturer specific. The host system puts the command into the object OS command, which shall be of the type Command Par:

Index	Sub-Index	Field in OS Command	Data Type
0025h	0h	Number of supported entries	UNSIGNED8
	1h	Command	OCTET_STRING
	2h	Status 0: Last Command completed, no errors, no reply. 1: Last Command completed, no errors, reply there. 2: Last Command completed, error, no reply. 3: Last Command completed, error, reply there. 4..254: undefined, reserved. 255: Command is executing.	UNSIGNED8
	03h	Reply	OCTET_STRING

OBJECT DESCRIPTION

INDEX	1023h
Name	OS command
Object Code	RECORD
Data Type	Command Par
Category	Optional

ENTRY DESCRIPTION

Sub-Index	0h
Description	number of supported entries
Entry Category	Mandatory
Access	ro
PDO Mapping	No
Value Range	3
Default Value	3

Sub-Index	1h
Description	Command
Entry Category	Mandatory
Access	rw
PDO Mapping	No
Value Range	No
Default Value	No

Sub-Index	2h
Description	Status
Entry Category	Mandatory
Access	ro
PDO Mapping	No
Value Range	UNSIGNED8
Default Value	No

Sub-Index	3h
Description	Replay
Entry Category	Mandatory
Access	ro
PDO Mapping	No
Value Range	No
Default Value	No

If a device implement this function, these entries are mandatory, additional entries are vendor specific. A new command may be entered, if Status is in the range 0..3: The command and all parameters shall be transmitted in one block to Sub-Index 1h. The execution of the command shall start immediately after the completion of the transfer. The host polls Sub-Index 2h, until it is 0 ..3. It may then transfer the reply, if Status is 1 or 3. The device shall return the same reply, if Reply is requested more then one time, or may change Status from 1 to 0 or 3 to 2, if it can not buffer the reply.

The following object dictionary entry controls the operational mode of the OS command:

OBJECT DESCRIPTION

INDEX	1024h
Name	OS command mode
Object Code	VAR
Data Type	UNSIGNED8
Category	Optional

ENTRY DESCRIPTION

Access	wo
PDO Mapping	No
Value Range	UNSIGNED8 0: Execute the next command immediately 1: Buffer the next command 2: Execute the commands in the buffer 3: Abort the current command and all commands in the buffer 4 .. 255: Manufacturer specific
Default Value	No

It is intended that the OS command object dictionary entry is the most recent entry in a queue and that this object controls the execution of this queue of commands.

11.3.2 OS debugger interface

The OS Debugger Interface object is the binary command interface to the debugger agents of the programmable devices. The contents of the commands are manufacturer specific. This object enables the user to connect with a remote debugger. It has the type Debugger Par:

Index	Sub-Index	Field in OS Debugger Interface	Data Type
0024h	0h	Number of supported entries	UNSIGNED8
	1h	Command	OCTET_STRING
	2h	Status 0: Last Command completed, no errors. 1: Last Command completed, error. 255: Command still executing.	UNSIGNED8
	03h	Reply	OCTET_STRING

OBJECT DESCRIPTION

INDEX	1025h
Name	OS debugger interface
Object Code	RECORD
Data Type	Debugger Par
Category	Optional

ENTRY DESCRIPTION

Sub-Index	0h
Description	number of supported entries
Entry Category	Mandatory
Access	ro
PDO Mapping	No
Value Range	3
Default Value	3

Sub-Index	1h
Description	Command
Entry Category	Mandatory
Access	rw
PDO Mapping	No
Value Range	No
Default Value	No

Sub-Index	2h
Description	Status
Entry Category	Mandatory
Access	ro
PDO Mapping	No
Value Range	UNSIGNED8
Default Value	No

Sub-Index	3h
Description	Replay
Entry Category	Mandatory
Access	ro
PDO Mapping	No
Value Range	No
Default Value	No

If a device implement this function, the entries 00h-03h are mandatory, additional entries are vendor specific. For command sequence, see OS Command Section.

11.3.3 OS prompt

The OS Prompt object is a character driven command interface to programmable devices. The contents of the commands are manufacturer specific. This object enables the user to have remote keyboard control.

OBJECT DESCRIPTION

INDEX	1026h
Name	OS prompt
Object Code	ARRAY
Data Type	UNSIGNED8
Category	Optional

ENTRY DESCRIPTION

Sub-Index	0h
Description	number of entries
Entry Category	Mandatory
Access	ro
PDO Mapping	No
Value Range	2 – 3
Default Value	No

Sub-Index	1h
Description	StdIn
Entry Category	Mandatory
Access	wo
PDO Mapping	Possible
Value Range	UNSIGNED8
Default Value	No

Sub-Index	2h
Description	StdOut
Entry Category	Mandatory
Access	ro
PDO Mapping	Optional
Value Range	UNSIGNED8
Default Value	No

Sub-Index	3h
Description	StdErr
Entry Category	Optional
Access	ro
PDO Mapping	Optional
Value Range	UNSIGNED8
Default Value	No

Sub-Index 1h StdIn can be used to transmit single characters to the device by SDO or PDO. Each new character is appended to the internal input queue. Answers of the device are output on Sub-Index

2h StdOut. This object can be mapped to an event-driven PDO or polled by SDO. Sub-Index 3h StdErr can be used for error output. This object can be mapped to an event-driven PDO or polled by SDO.

The application is responsible for handling queue overruns.

11.4 Multiplexed PDOs

11.4.1 MPDO Protocol

This protocol is used to implement MPDO services. The MPDO producer sends data and the multiplexor indicating the source or destination address.

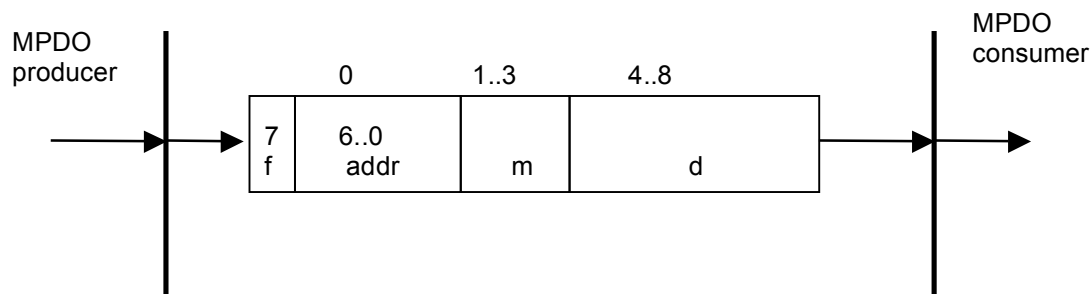

'd' shall contain the data to be transferred. The value always shall be filled up to 32 bit.⁴

'm' shall contain the multiplexor (Index and Sub-Index) of the variable in the object dictionary.

The MSB 'f' of the first byte shall be a format flag, and 'addr' shall be an address field, which may be used in the following combinations:

f	addr	usage
0	0	reserved
0	1-127	Source addressing. addr is a single producer's Node ID. Multiplexor is index and sub-index of the object dictionary of the producer.
1	0	Destination addressing. The consumer is a group.
1	1-127	Destination addressing. addr is a single consumer's Node ID. Multiplexor is index and sub-index of the object dictionary of the consumer.

11.4.1.1 Destination Address Mode (DAM)

The *addr* and the *m* field of the MPDO refers to the consumer. This allows access to the consumer's Object Dictionary in an SDO-like manner. With *addr* = 0, it allows multicasting and broadcasting, to write into the Object Dictionaries of more than one node simultaneously, without having a PDO for each single object.

Initiating a DAM-MPDO is application-dependent, like it is for SDOs.

11.4.1.2 Source Address Mode (SAM)

The *addr* and the *m* field of the MPDO refers to the producer. Only one producer MPDO of this type is allowed for each node.

Transmission type has to be 254 or 255.

The producer uses an Object Scanner List in order to know, which objects are to send.

The consumer uses an Object Dispatcher List as a 'cross reference'.

⁴ The restriction about using 32-bit transfers only will not present problems in practice since all of the participating devices know the data types (and sizes) of their related objects.

11.4.2 Object dictionary entries

11.4.2.1 PDO Mapping Record

The meaning of Sub-Index 0 (number of mapped objects is extended. The valid range for non-multiplexed PDOs is 0 to 64. A value of 255 indicates a DAM-MPDO, a value of 254 indicates an SAM-MPDO.

For SAM, the further entries in the MR are don't care.

For DAM the first object describes the local object (there can be mapped only one object into an MPDO).

There are additional values allowed for the objects 1600h – 17FFh and 1A00h – 1BFFh Sub-Index 0h:

- 0 .. 64: Valid range for number of mapped objects
- 254: formatted as SAM-MPDO
- 255: formatted as DAM-MPDO

11.4.2.2 Object Dispatching List

The consumer of an SAM-MPDO uses the Object Dispatching List as a cross reference between the remote object of the producer and local object dictionary.

OBJECT DESCRIPTION

INDEX	1FD0h – 1FFFh
Name	Object dispatching list
Object Code	ARRAY
Data Type	UNSIGNED64
Category	Optional

ENTRY DESCRIPTION

Sub-Index	0h
Description	number of entries
Entry Category	Mandatory
Access	ro
PDO Mapping	No
Value Range	1 – FEh
Default Value	No

Sub-Index	1h
Description	Dispatch_1
Entry Category	Mandatory
Access	rw
PDO Mapping	No
Value Range	UNSIGNED64
Default Value	No

Sub-Index	2h – FEh
Description	Dispatch_2 – Dispatch_254
Entry Category	Optional
Access	rw
PDO Mapping	No
Value Range	UNSIGNED64
Default Value	No

The fields shall have the following structure:

	Unsigned64					
	MSB					LSB
bits	56-63	40-55	32-39	16-31	8-15	0-7
field	Block Size	Local Index	Local Sub-Index	Sender Index	Sender Sub-Index	Sender Node-ID

Each table entry describes how the data of a received MPDO is transferred to the local Object Dictionary. If the flag field is 0 and the producer Node ID, the producer Index and producer Sub-Index fit to the entry, then the data shall be written to the local object addressed by the values Local Index and Local Sub-Index of that entry.

The parameter Block Size allows the description of consecutive sub-indexes to be used. Example: if sub-index 1-9 of the sender shall be mapped to sub-index 11-19 of the receiver, this range is defined by

Sender Sub-Index = 1
 Local Sub-Index = 11
 Block Size = 9

Entries that are not configured shall have the value 0.

11.4.2.3 Object Scanner List

The producer of an SAM-MPDO uses the Object Scanner List to configure, which objects shall be transmitted. The transmission type is given by the corresponding field of the used PDO.

OBJECT DESCRIPTION

INDEX	1FA0h – 1FCFh
Name	Object scanner list
Object Code	ARRAY
Data Type	UNSIGNED32
Category	Optional

ENTRY DESCRIPTION

Sub-Index	0h
Description	number of entries
Entry Category	Mandatory
Access	ro
PDO Mapping	No
Value Range	1 – FEh
Default Value	No

Sub-Index	1h
Description	Scan_1
Entry Category	Mandatory
Access	rw
PDO Mapping	No
Value Range	UNSIGNED32
Default Value	No

Sub-Index	2h – FEh
Description	Scan_2 – Scan_254
Entry Category	Optional
Access	rw
PDO Mapping	No
Value Range	UNSIGNED32
Default Value	No

The fields have the following structure:

	Unsigned32		
	MSB		LSB
bits	24-31	8-23	0-7
field	Block Size	Index	Sub-Index

Each table entry describes an object that can be sent via the MPDO. It is possible to describe consecutive sub-indexes by setting the parameter Block Size to the number of sub-indexes.

Entries that are not configured shall have the value 0.

11.4.3 Implementing MPDOs

MPDO Producer – If a node has specified one or more MPDO to be transmitted the following implementation rules apply:

- If it is an SAM-MPDO, the Object Scanner List together with the transmission type is used to determine, which object to send (there shall be only one SAM-MPDO to be transmitted).
- If it is a DAM-MPDO, the local object may be specified in the Mapping Parameter Set object as usual. The Destination Object and Node ID may be specified application specific.

MPDO Consumer – If a node receives an MPDO (which is known by the Mapping Parameter Set object) the following implementation rules apply:

- If it is an DAM-MPDO, it writes the received data to the specified Object Dictionary entry.
- If it is a SAM-MPDO, it has to use the Object Dispatching List as a 'cross reference'.

11.4.4 Groups, security and network configuration tools

A described group messaging scheme is highly efficient using only one DAM-MPDO per group. A node, which is the consumer of a group needs only to receive the MPDO for that group. There is no limit to the number of groups except that imposed by the number of free COB-IDs for PDOs.

There is no attempt, at the CANopen level, to guard against the misuse of a PDO used for group messaging purposes.

11.4.5 Indication of MPDO capability in the EDS

For a transparent usage by configuration tools, it is required to have the knowledge, if a device supports the group mechanism. This shall be marked in the EDS in section `DeviceInfo` with the boolean entry `GroupMessaging`.

11.5 Additional functionality for modular CANopen devices

11.5.1 Background

The actual EDS specification allows the description of modular devices. With this it is possible to perform the Conformance Test for those devices without the need of writing a pseudo EDS with the concretely attached modules. Furthermore it is possible to describe those devices for the purpose of project planning or configuration in manufacturer independent software tools.

In practical work one problem is arising: A common task is the scanning of a network with displaying the results as a set of DCF files. For this purpose the scanning software will implement some algorithms to scan the objects of a device and automatically assign the corresponding EDS, then read-out the object contents and create the DCF. With modular devices this is not always possible.

Assume a bus coupler device and three available module types: Module Type A has 8 digital outputs, Module Type B has 8 digital inputs and Module Type C has a combination of 8 Inputs and 8 Outputs. Assume a configuration software scans such a device and detects that it consists of 8 digital inputs and 8 digital outputs. Then it cannot decide, if this combination is built up by attaching one Module Type C or by attaching one Module A and one Module B.

This inconsistency will cause trouble at the users side. This will cause explanation effort by module manufacturers and tool providers. The user will get a feeling, that CANopen is so complicated. To avoid this a small extension of the bus couplers object dictionary will solve that problem.

The idea is that the bus coupler contains an object that contains a list of the attached modules. A tool scanning that device can read-out that list and then has a consistent knowledge about the concretely attached modules.

11.5.2 Modular Devices

A common method to provide modular devices is the usage of a bus coupler that allows to connect several combinations of modules. Object 1027h Module List describes the concretely attached modules.

OBJECT DESCRIPTION

INDEX	027hh
Name	Module list
Object Code	ARRAY
Data Type	UNSIGNED16
Category	Conditional; Mandatory, if modular devices supported

ENTRY DESCRIPTION

Sub-Index	0h
Description	number of connected modules
Entry Category	Mandatory
Access	ro
PDO Mapping	No
Value Range	1 – FEh
Default Value	No

Sub-Index	1h – FEh
Description	Module_2 – Module_254
Entry Category	Optional
Access	rw
PDO Mapping	No
Value Range	UNSIGNED16
Default Value	No

The consecutive sub-indexes ($1 \leq N \leq 254$) describe the corresponding modules in the order they are attached. Each entry contains a number that identifies the module. For this the number must be unique within all module types that can be attached to this bus coupler device type.

In the EDS (refer to DSP-306) object 1027h appears in the SubExtension list of each module. The entry `DefaultValue` shall contain the identification number.

11.6 Additional communication objects

11.6.1 Emergency consumer object

This object defines the Emergency COB-IDs that an NMT slave device is consuming. The structure of the object is as follows:

UNSIGNED32					
MSB				LSB	
bits	31	30	29	28-11	10-0
11-bit-ID	0/1	0	0	0 0	11-bit Identifier
29-bit-ID	0/1	0	1	29-bit Identifier	

bit number	value	Meaning
31 (MSB)	0	EMCY exists / is valid
	1	EMCY does not exist / is not valid
30	0	reserved (always 0)
29	0	11-bit ID (CAN 2.0A)
	1	29-bit ID (CAN 2.0B)
28 - 11	0	if bit 29=0
	X	if bit 29=1: bits 28-11 of 29-bit-COB-ID
10-0 (LSB)	X	bits 10-0 of COB-ID

Devices supporting the standard CAN frame type only, an attempt to set bit 29 is responded with an abort message (abort code: 0609 0030h). It is not allowed to change Bits 0-29, while the object is existing (Bit 31=0).

The Sub-Index refers to the related Node-ID.

OBJECT DESCRIPTION

INDEX	1028h
Name	Emergency Consumer
Object Code	ARRAY
Data Type	UNSIGNED32
Category	Optional

ENTRY DESCRIPTION

Sub-Index	0h
Description	No. of Emergency Consumer
Entry Category	Mandatory
Access	ro
PDO Mapping	No
Value Range	1 – 127
Default Value	No

Sub-Index	1h
Description	Emergency Consumer 1
Entry Category	Mandatory
Access	rw
PDO Mapping	No
Value Range	UNSIGNED32
Default Value	No

Sub-Index	2h – 7Fh
Description	Emergency Consumer 2 to 127
Entry Category	Optional
Access	rw
PDO Mapping	No
Value Range	UNSIGNED32
Default Value	No

11.6.2 Error behaviour object

If a serious device failure is detected in Operational State, the module shall enter by default autonomously the pre-operational state. If object 1029h (Error Behaviour) is implemented, the device can be configured to enter alternatively the stopped state or remain in the current state in case of a device failure. Device failures shall include the following communication errors:

- Bus-off conditions of the CAN interface
- Life guarding event with the state 'occurred'
- Heartbeat event with state 'occurred'

Severe device errors also can be caused by device internal failures.

The value of the Error Classes is as follows:

0	pre-operational (only if current state is operational)
1	no state change
2	stopped
3 .. 127	reserved

OBJECT DESCRIPTION

INDEX	1029h
Name	Error Behaviour
Object Code	ARRAY
Data Type	UNSIGNED8
Category	Optional

ENTRY DESCRIPTION

Sub-Index	0h
Description	No. of Error Classes
Entry Category	Mandatory
Access	ro
PDO Mapping	No
Value Range	1h to FEh
Default Value	No

Sub-Index	1h
Description	Communication Error
Entry Category	Mandatory
Access	rw
PDO Mapping	No
Value Range	UNSIGNED8
Default Value	0

Sub-Index	2h to FEh
Description	Device profile or manufacturer specific Error
Entry Category	Optional
Access	rw
PDO Mapping	No
Value Range	UNSIGNED8
Default Value	No

12 Index

access attributes	81	life-	70
ARRAY	80	node-	70
bit timing	21	inhibit time	19
communication model		multi device module	
client server relationship.....	20	data types	81
master slave relationship.....	19	general	18
producer consumer relationship	20	network initialisation.....	75
communication status		NULL	80
initialising	77	object dictionary	17
operational	78	communication entries.....	81
pre-operational	78	data types	81
reset application	77	general structure	80
reset communication.....	77	structure	17
stopped	78	structured entries	83
data type		object name	80
BOOLEAN	26	pre-defined connection set.....	78
compound.....	29	process data object	
DOMAIN	30	general	30
INTEGERn.....	27	transmission mode.....	31
NIL.....	26	triggering mode	31
OCTET_STRING	29	protocol specification	15
REAL32	28	RECORD	80
TIME_DIFFERENCE	30	reference model	15
TIME_OF_DAY	29	service data object	
UNICODE_STRING.....	29	abort codes	49
UNSIGNEDn	26	block download.....	39
VISIBLE STRING	29	block upload	40
VOIDn	26	download.....	35
DEFSTRUCT	80	general	34
DEFTYPE.....	80	upload	37
device model.....	16	service objects	15
device profile.....	17	service primitives	15
DOMAIN	80	service specification.....	15
dummy mapping	81	service type	16
error control		state diagram.....	75
general.....	65	state transitions	78
guarding		VAR.....	80