

# CABLE ASSEMBLY SCHEMES

## for *Power Recycling* cabling

### Change History

<b>Version</b>	<b>Date</b>	<b>Changes/Reasons</b>	<b>Authors</b>
<b>v1</b>	jul-oct 2000	initial suspension cabling	Ceccanti, Dattilo, Nenci
<b>v2</b>	2003	added cabling of sensors and actuators on Filter #7	Dattilo, Nenci
<b>v3r0</b>	apr 2015	Modified cabling for allow new separating roof and new payload (cables F,R,S,U,V) and new F#7 actuation/sensing system (T, W, Z). Pre-existing cables U, X and Z suppressed. No more tiltmeters on F#7, more devices on payload.	Berni, Dattilo, Gherardini
<b>v3r1</b>	28sep15	small amendments before translation for the schemes of the air-side cables	Dattilo

### **Contents**

<b>INFORMAZIONI GENERALI .....</b>	<b>2</b>
<b>Identificazione componenti.....</b>	<b>2</b>
<b>Legenda .....</b>	<b>3</b>
<b>LEMO pinout of the main devices .....</b>	<b>3</b>
<b>CABLE A (VACUUM SIDE) .....</b>	<b>4</b>
<b>CABLE B (VACUUM SIDE) .....</b>	<b>5</b>
<b>CABLE C (VACUUM SIDE) .....</b>	<b>6</b>
<b>CABLE D (VACUUM SIDE) .....</b>	<b>7</b>
<b>CABLE E (VACUUM SIDE).....</b>	<b>8</b>
<b>CABLE F (VACUUM SIDE).....</b>	<b>9</b>
<b>CABLE G (VACUUM SIDE) .....</b>	<b>10</b>
<b>CABLE H (VACUUM SIDE) .....</b>	<b>11</b>
<b>CABLE J (VACUUM SIDE).....</b>	<b>12</b>
<b>CABLE K (VACUUM SIDE) .....</b>	<b>13</b>
<b>CABLE L (VACUUM SIDE).....</b>	<b>14</b>
<b>CABLE M (VACUUM SIDE).....</b>	<b>15</b>
<b>CABLE N (VACUUM SIDE) .....</b>	<b>16</b>
<b>CABLE O (VACUUM SIDE) .....</b>	<b>17</b>
<b>CABLE P (VACUUM SIDE).....</b>	<b>18</b>
<b>CABLE Q (VACUUM SIDE) .....</b>	<b>19</b>
<b>CABLE R (VACUUM SIDE) .....</b>	<b>20</b>
<b>CABLE S (VACUUM SIDE).....</b>	<b>21</b>
<b>CABLE T (VACUUM SIDE).....</b>	<b>22</b>
<b>CABLE U (VACUUM SIDE) .....</b>	<b>23</b>
<b>CABLE V (VACUUM SIDE).....</b>	<b>24</b>
<b>CABLE W (VACUUM SIDE).....</b>	<b>25</b>
<b>CABLE Z (VACUUM SIDE).....</b>	<b>26</b>

## **Informazioni generali**

Ciascun spezzone di cavo va terminato ad una estremità da un connettore circolare 32 poli (tipo presa), all'altra estremità con uno o più connettori Lemo multipolari (generalmente tipo spina). I cavi sono del tipo:

- cavo piatto a 18 o 20 conduttori trefolati AWG 24, isolati in goretex, a coppie ritorte e schermate singolarmente (cavo STP).
- cavo assemblato in lab a conduttori solidi AWG 18, isolati in polimide, a coppie ritorte (cavo TP).
- cavo assemblato in lab a conduttori solidi AWG 22, isolati in polimide, a triplette ritorte (cavo TT).

## **Identificazione componenti**

- Ciascun cavo è identificato da una lettera dell'alfabeto.
- Il tipo di cavo utilizzato e' indicato in prossimità del disegno: la sigla comprende il numero di coppie di conduttori, il tipo di schermatura (STP, TP, TT), la sezione (es. AWG24). Es.: la sigla **9.STP.AWG24** specifica un tipo di cavo avente 18 conduttori intrecciati e schermati a coppie, di sezione AWG24
- Ciascun conduttore di un cavo STP è identificato da un numero cardinale relativo alla coppia (**1** per la coppia bianco/rossa a seguire fino ad **9** per le altre coppie bianco/gialle), da una lettera (**A** per il conduttore con isolante a strisce rosse, **B** per l'altro conduttore della coppia, **S** per la calza) (es. la calza nella terza coppia, è identificata da **3.S** ).
- Ciascun connettore Lemo è identificato da due caratteri: il primo è la lettera del cavo sul quale è saldato il connettore, il secondo è un numero cardinale, che va da 1 al n. max di connettori Lemo sullo stesso cavo (es. per il cavo **B** terminato da due Lemo, essi sono identificati da **B1** e **B2**)
- I contatti di ciascun connettore Lemo sono identificati dal nome del connettore, seguito dal numero del contatto indicato sull'isolante del connettore (es. il contatto<sup>1</sup> n. 4 che si trova sul connettore Lemo **B3** e' identificato da **B3.4**)
- I contatti di ciascun connettore circolare a 32 poli sono identificati da lettere (A÷Z, a÷j). Per quelli interni vale il pinout serigrafato sul retro dell'isolante, per quo 20elli esterni vale il pinout standard

---

<sup>1</sup> Nel caso di conduttori Lemo, il contatto n. 1 e' quello col semicerchio bianco, i successivi sono quelli lungo la linea bianca che parte dal contatto n. 1.

## Legenda

<b>F1 +</b>	motore, fase 1, positivo
<b>F1 -</b>	motore, fase 1, negativo
<b>F2 +</b>	motore, fase 2, positivo
<b>F2 -</b>	motore, fase 2, negativo
<b>FC cw</b>	motore, fine corsa che si incontra quando l'albero gira in senso orario per un osservatore coincidente con il motore
<b>FC ccw</b>	motore, fine corsa che si incontra quando l'albero gira in senso antiorario per un osservatore coincidente con il motore
<b>FC com</b>	motore, fine corsa, comune
<b>RST up</b>	motore, reostato, terminale superiore
<b>RST down</b>	motore, reostato, terminale inferiore
<b>RST com</b>	motore, reostato, comune o cursore
<b>TP sx +</b>	thermal probe, sinistro, positivo
<b>TP sx -</b>	thermal probe, sinistro, negativo
<b>TP dx +</b>	thermal probe, destro, positivo
<b>TP dx -</b>	thermal probe, destro, negativo
<b>Ls</b>	LVDT, secondario
<b>Lp</b>	LVDT, primario
<b>C +</b>	coil attuatore, positivo
<b>C -</b>	coil attuatore, negativo
<b>fbk</b>	accelerometro, feedback
<b>RH +</b>	Reinh Heater, positivo
<b>RH -</b>	Ring Heater, negativo

## LEMO pinout of the main devices

<b>ACCELEROMETER</b>	
LEMO contacts	Contact descript.
1	Lp
2	Lp
3	
4	F1 +
5	F1 -
6	F2 +
7	F2 -
8	
9	FC cw
11	FC ccw
10	FC com
12	fbk
13	fbk
14	
15	Ls
16	Ls
17	
18	

<b>LVDT</b>	
LEMO contacts	Contact descript.
1	Lp +
2	Lp -
3	Ls +
4	Ls -

<b>COIL</b>	
LEMO contacts	Contact descript.
1	C +
2	C -

<b>MOTOR</b>		
LEMO contacts	Contact descript.	UTG 12p contacts
1	F1 +	A
2	F1 -	B
	F1 shield	C
3	F2 +	D
4	F2 -	E
	F2 shield	F
5	FC cw	G
6	FC ccw	H
7	FC com	J
8	n.c.	

**cable A** (vacuum side)

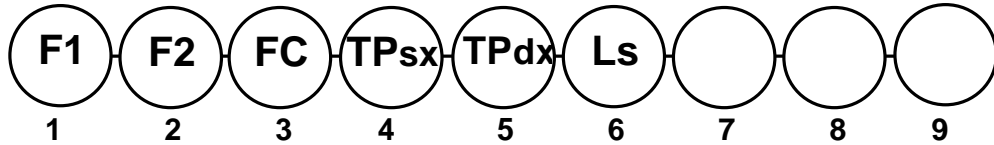
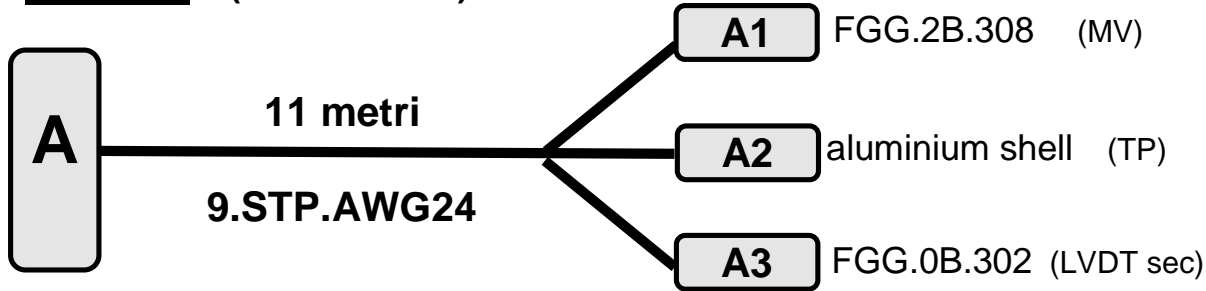

Cutting and Stripping phase
Date:
Operator:
Reel:

Crimping and Labeling phase
Date:
Operator:
Duration (hours):

Quality Control phase
Date:
Operator:

Cleaning and Storage phase
Date:
Operator:

Notes:
Diramare a 60 cm

MIL-32 contacts	conductors	LEMO contacts	contact description
A	1.A	A1.1	F1 +
B	1.B	A1.2	F1 -
C	1.S	n.c.	
D	2.A	A1.3	F2 +
E	2.B	A1.4	F2 -
F	2.S	n.c.	
G	3.A	A1.5	FC cw
H	3.B	A1.6	FC ccw
J	3.S	A1.7	FC com
K	4.A	A2	TP sx +
L	4.B	A2	TP sx -
M	4.S	n.c.	
N	5.A	A2	TP dx +
P	5.B	A2	TP dx -
R	5.S	n.c.	
S	6.A	A3.1	Ls
T	6.B	A3.2	Ls
U	6.S	n.c.	
V	7.A		
W	7.B		
X	7.S		
Y	8.A		
Z	8.B		
a	8.S		
b	9.A		
c	9.B		
d	9.S		

**cable B** (vacuum side)

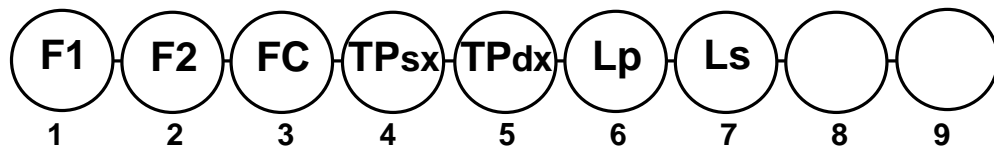
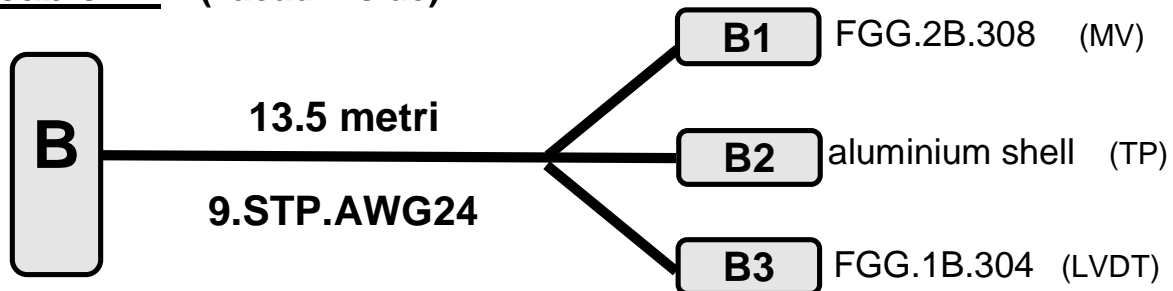

Cutting and Stripping phase
Date:
Operator:
Reel:

Crimping and Labeling phase
Date:
Operator:
Duration (hours):

Quality Control phase
Date:
Operator:

Cleaning and Storage phase
Date:
Operator:

Notes:
Diramare a 60 cm

MIL-32 contacts	conductors	LEMO contacts	contact description
A	1.A	B1.1	F1 +
B	1.B	B1.2	F1 -
C	1.S	n.c.	
D	2.A	B1.3	F2 +
E	2.B	B1.4	F2 -
F	2.S	n.c.	
G	3.A	B1.5	FC cw
H	3.B	B1.6	FC ccw
J	3.S	B1.7	FC com
K	4.A	B2	TP sx +
L	4.B	B2	TP sx -
M	4.S	n.c.	
N	5.A	B2	TP dx +
P	5.B	B2	TP dx -
R	5.S	n.c.	
S	6.A	B3.1	Lp
T	6.B	B3.2	Lp
U	6.S	n.c.	
V	7.A	B3.3	Ls
W	7.B	B3.4	Ls
X	7.S	n.c.	
Y	8.A		
Z	8.B		
a	8.S		
b	9.A		
c	9.B		
d	9.S		

**cable C** (vacuum side)

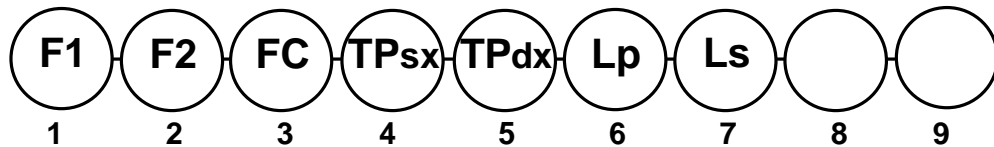
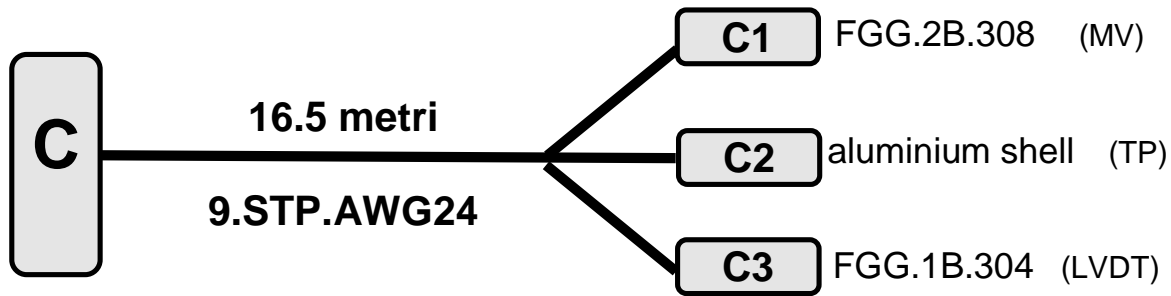

Cutting and Stripping phase
Date:
Operator:
Reel:

Crimping and Labeling phase
Date:
Operator:
Duration (hours):

Quality Control phase
Date:
Operator:

Cleaning and Storage phase
Date:
Operator:

Notes:
Diramare a 60 cm

MIL-32 contacts	conductors	LEMO contacts	contact description
A	1.A	C1.1	F1 +
B	1.B	C1.2	F1 -
C	1.S	n.c.	
D	2.A	C1.3	F2 +
E	2.B	C1.4	F2 -
F	2.S	n.c.	
G	3.A	C1.5	FC cw
H	3.B	C1.6	FC ccw
J	3.S	C1.7	FC com
K	4.A	C2	TP sx +
L	4.B	C2	TP sx -
M	4.S	n.c.	
N	5.A	C2	TP dx +
P	5.B	C2	TP dx -
R	5.S	n.c.	
S	6.A	C3.1	Lp
T	6.B	C3.2	Lp
U	6.S	n.c.	
V	7.A	C3.3	Ls
W	7.B	C3.4	Ls
X	7.S	n.c.	
Y	8.A		
Z	8.B		
a	8.S		
b	9.A		
c	9.B		
d	9.S		

**cable D** (vacuum side)

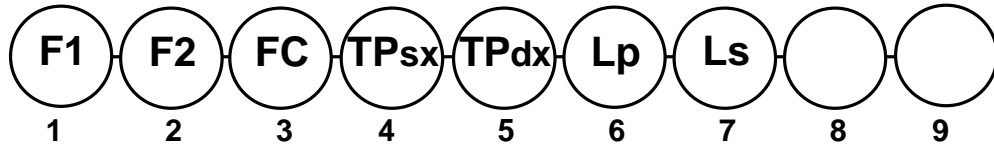
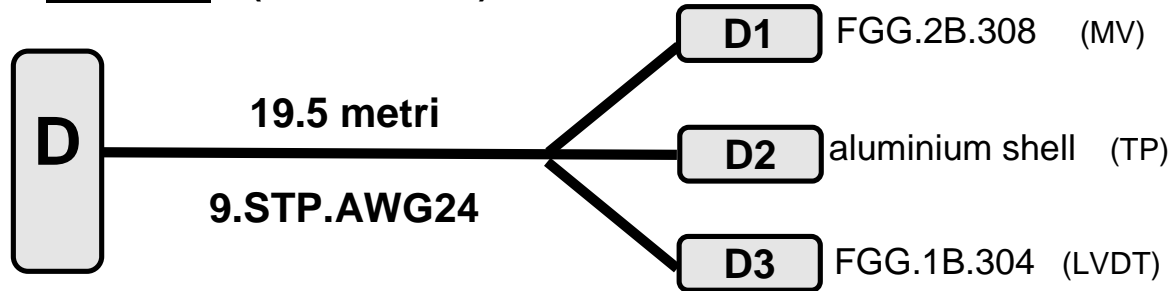

Cutting and Stripping phase
Date:
Operator:
Reel:

Crimping and Labeling phase
Date:
Operator:
Duration (hours):

Quality Control phase
Date:
Operator:

Cleaning and Storage phase
Date:
Operator:

<b>Notes:</b>	<b>7</b>
Diramare a 60 cm	

MIL-32 contacts	conductors	LEMO contacts	contact description
A	1.A	D1.1	F1 +
B	1.B	D1.2	F1 -
C	1.S	n.c.	
D	2.A	D1.3	F2 +
E	2.B	D1.4	F2 -
F	2.S	n.c.	
G	3.A	D1.5	FC cw
H	3.B	D1.6	FC ccw
J	3.S	D1.7	FC com
K	4.A	D2	TP sx +
L	4.B	D2	TP sx -
M	4.S	n.c.	
N	5.A	D2	TP dx +
P	5.B	D2	TP dx -
R	5.S	n.c.	
S	6.A	D3.1	Lp
T	6.B	D3.2	Lp
U	6.S	n.c.	
V	7.A	D3.3	Ls
W	7.B	D3.4	Ls
X	7.S	n.c.	
Y	8.A		
Z	8.B		
a	8.S		
b	9.A		
c	9.B		
d	9.S		

**cable E** (vacuum side)

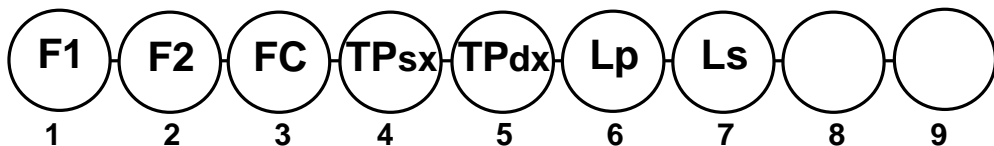
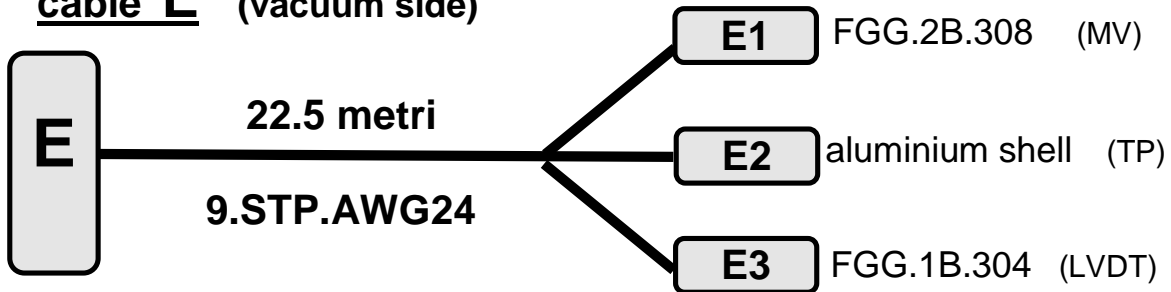

Cutting and Stripping phase
Date:
Operator:
Reel:

Crimping and Labeling phase
Date:
Operator:
Duration (hours):

Quality Control phase
Date:
Operator:

Cleaning and Storage phase
Date:
Operator:

Notes:
Diramare a 60 cm

MIL-32 contacts	conductors	LEMO contacts	contact description
A	1.A	E1.1	F1 +
B	1.B	E1.2	F1 -
C	1.S	n.c.	
D	2.A	E1.3	F2 +
E	2.B	E1.4	F2 -
F	2.S	n.c.	
G	3.A	E1.5	FC cw
H	3.B	E1.6	FC ccw
J	3.S	E1.7	FC com
K	4.A	E2	TP sx +
L	4.B	E2	TP sx -
M	4.S	n.c.	
N	5.A	E2	TP dx +
P	5.B	E2	TP dx -
R	5.S	n.c.	
S	6.A	E3.1	Lp
T	6.B	E3.2	Lp
U	6.S	n.c.	
V	7.A	E3.3	Ls
W	7.B	E3.4	Ls
X	7.S	n.c.	
Y	8.A		
Z	8.B		
a	8.S		
b	9.A		
c	9.B		
d	9.S		



**cable F** (vacuum side)

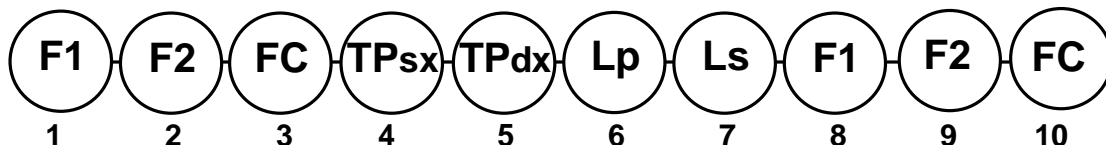
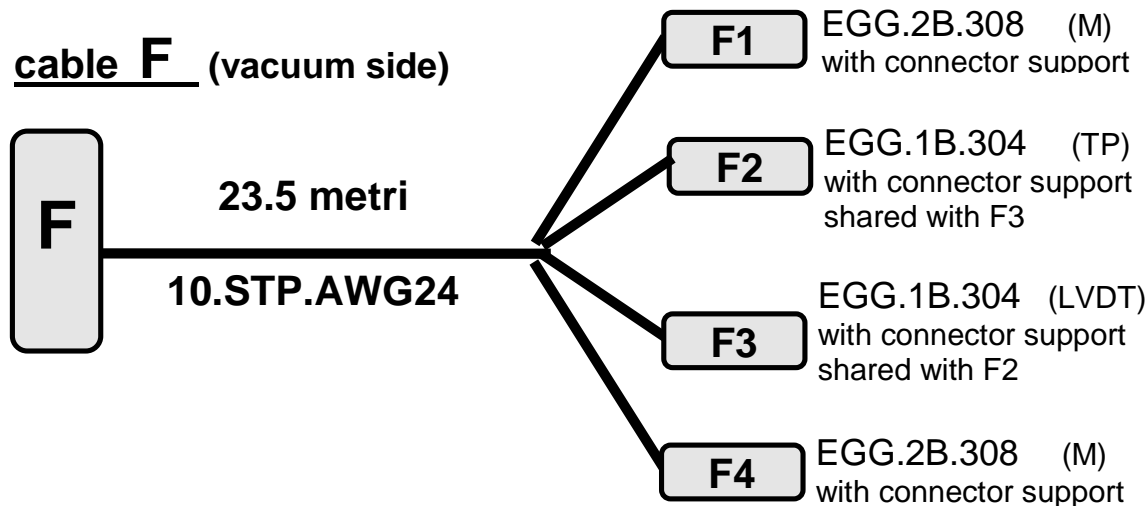

Cutting and Stripping phase
Date:
Operator: <i>F.Berni</i>
Reel:

Crimping and Labeling phase
Date:
Operator: <i>F.Berni</i>
Duration (hours):

Quality Control phase
Date: <i>24apr15</i>
Operator: <i>F.Berni</i>

Cleaning and Storage phase
Date:
Operator:

Notes:
Rifatto ex-novo a Aprile 2015. Per lo schema del vecchio cavo F vedere la versione v3.
<b>NB:</b> inserire il lemo da pannello nell'apposito clamp a C.
Diramare a 30 cm
Connectors F2 and F3 share the same connector support.

MIL-32 contacts	conductors	LEMO contacts	contact description
A	1.A	F1.1	F1 +
B	1.B	F1.2	F1 -
C	1.S	n.c.	
D	2.A	F1.3	F2 +
E	2.B	F1.4	F2 -
F	2.S	n.c.	
G	3.A	F1.5	FC cw
H	3.B	F1.6	FC ccw
J	3.S	F1.7	FC com
K	4.A	F2.1	TP sx +
L	4.B	F2.2	TP sx -
M	4.S	n.c.	
N	5.A	F2.3	TP dx +
P	5.B	F2.4	TP dx -
R	5.S	n.c.	
S	6.A	F3.1	Lp
T	6.B	F3.2	Lp
U	6.S	n.c.	
V	7.A	F3.3	Ls
W	7.B	F3.4	Ls
X	7.S	n.c.	
Y	8.A	F4.1	F1 +
Z	8.B	F4.2	F1 -
a	8.S	n.c.	
b	9.A	F4.3	F2 +
c	9.B	F4.4	F2 -
d	9.S	n.c.	
e	10.A	F4.5	FC sx
f	10.B	F4.6	FC dx
g	10.S	F4.7	FC com

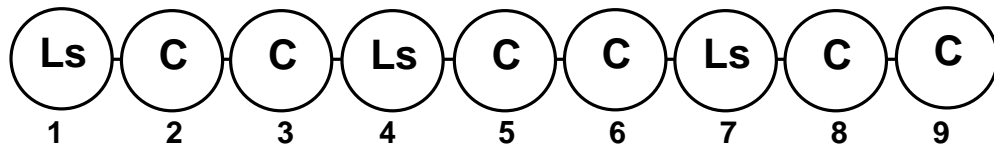
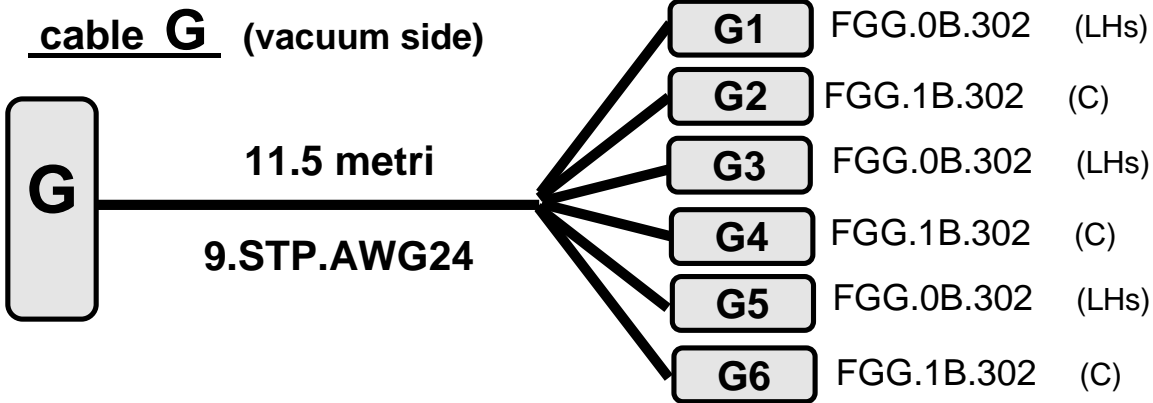

Cutting and Stripping phase
Date:
Operator:
Reel:

Crimping and Labeling phase
Date:
Operator:
Duration (hours):

Quality Control phase
Date:
Operator:

Cleaning and Storage phase
Date:
Operator:

**Notes:**  
 Diramare a gruppi (G1+G2, G3+G4, G5+G6) di 2.5 metri;  
 Scorciare G3+G4 di 1.5 metri rispetto ai 11.5 metri totali;  
 Ponticelli su MIL-32.

MIL-32 contacts	conductors	LEMO contacts	contact description
A	1.A	G1.1	Ls
B	1.B	G1.2	Ls
C	1.S	n.c.	
D	2.A	G2.1	C +
E	2.B	G2.2	C -
F	2.S	n.c.	
G	3.A	G2.1	C +
H	3.B	G2.2	C -
J	3.S	n.c.	
K	4.A	G3.1	Ls
L	4.B	G3.2	Ls
M	4.S	n.c.	
N	5.A	G4.1	C +
P	5.B	G4.2	C -
R	5.S	n.c.	
S	6.A	G4.1	C +
T	6.B	G4.2	C -
U	6.S	n.c.	
V	7.A	G5.1	Ls
W	7.B	G5.2	Ls
X	7.S	n.c.	
Y	8.A	G6.1	C +
Z	8.B	G6.2	C -
a	8.S	n.c.	
b	9.A	G6.1	C +
c	9.B	G6.2	C -
d	9.S	n.c.	

**cable H** (vacuum side)

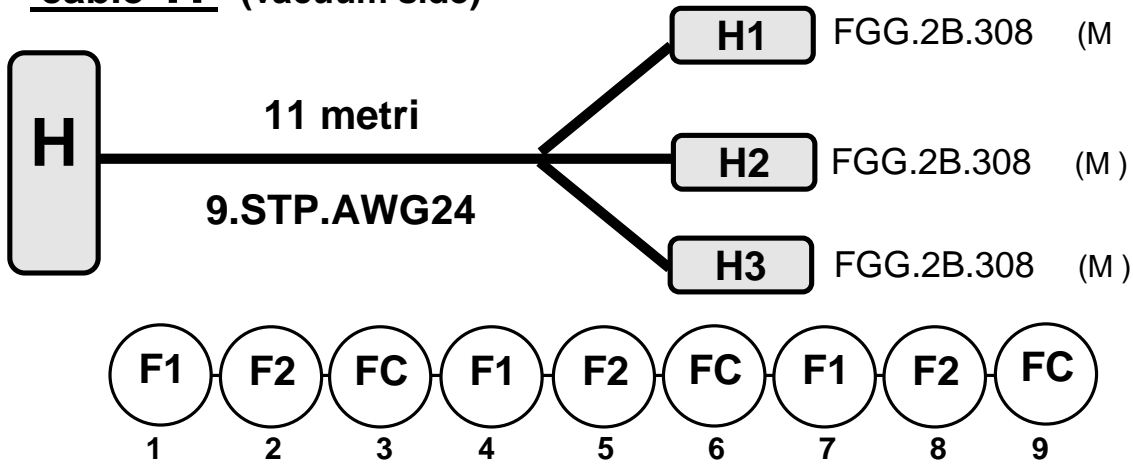

Cutting and Stripping phase
Date:
Operator:
Reel:

Crimping and Labeling phase
Date:
Operator:
Duration (hours):

Quality Control phase
Date:
Operator:

Cleaning and Storage phase
Date:
Operator:

Notes:
Diramare di <u>2,5 metri</u> ;
Scorciare H2 di <u>1.5 metri</u> .

MIL-32 contacts	conductors	LEMO contacts	contact description
A	1.A	H1.1	F1 +
B	1.B	H1.2	F1 -
C	1.S	n.c.	
D	2.A	H1.3	F2 +
E	2.B	H1.4	F2 -
F	2.S	n.c.	
G	3.A	H1.5	FC cw
H	3.B	H1.6	FC ccw
J	3.S	H1.7	FC com
K	4.A	H2.1	F1 +
L	4.B	H2.2	F1 -
M	4.S	n.c.	
N	5.A	H2.3	F2 +
P	5.B	H2.4	F2 -
H	5.S	n.c.	
S	6.A	H2.5	FC cw
T	6.B	H2.6	FC ccw
U	6.S	H2.7	FC com
V	7.A	H3.1	F1 +
W	7.B	H3.2	F1 -
X	7.S	n.c.	
Y	8.A	H3.3	F2 +
Z	8.B	H3.4	F2 -
a	8.S	n.c.	
b	9.A	H3.5	FC cw
c	9.B	H3.6	FC ccw
d	9.S	H3.7	FC com

**cable J** (vacuum side)

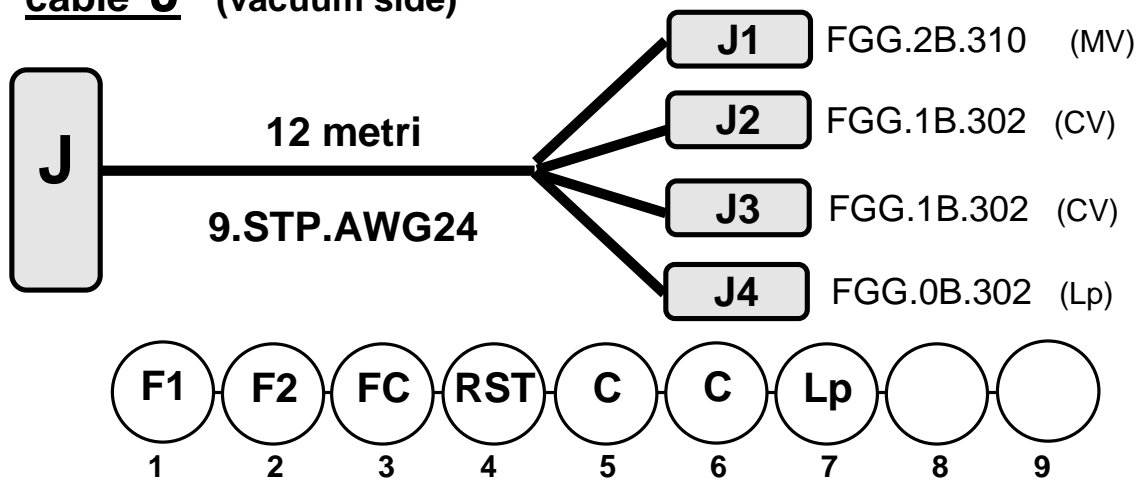

Cutting and Stripping phase
Date:
Operator:
Reel:

Crimping and Labeling phase
Date:
Operator:
Duration (hours):

Quality Control phase
Date:
Operator:

Cleaning and Storage phase
Date:
Operator:

**Notes:**  
 Diramare a 120 cm tra J2 e J3;  
 Diramare J3 e J4 di 25 cm;  
 Scorciare J1 di 120 cm;  
 Scorciare J2 di 20 cm.

RST e' il reostato, usato come sensore di posizione dell'hoist.

MIL-32 contacts	conductors	LEMO contacts	contact description
A	1.A	J1.1	F1 +
B	1.B	J1.2	F1 -
C	1.S	n.c.	
D	2.A	J1.3	F2 +
E	2.B	J1.4	F2 -
F	2.S	n.c.	
G	3.A	J1.5	FC cw
H	3.B	J1.6	FC ccw
J	3.S	J1.7	FC com
K	4.A	J1.8	RST down
L	4.B	J1.9	RST up
M	4.S	J1.10	RST com
N	5.A	J2.1	C+
P	5.B	J2.2	C-
R	5.S	n.c.	
S	6.A	J3.1	C+
T	6.B	J3.2	C-
U	6.S	n.c.	
V	7.A	J4.1	Lp
W	7.B	J4.2	Lp
X	7.S	n.c.	
Y	8.A		
Z	8.B		
a	8.S		
b	9.A		
c	9.B		
d	9.S		

**cable K** (vacuum side)

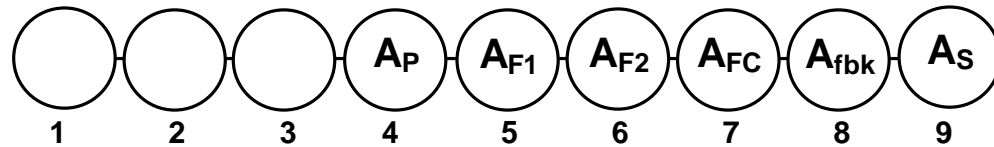
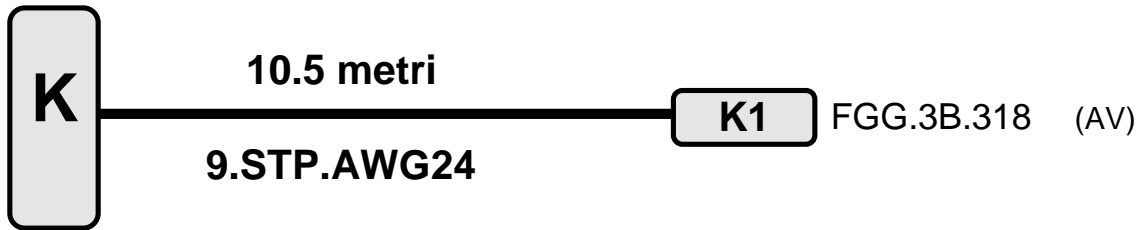

Cutting and Stripping phase
Date:
Operator:
Reel:

Crimping and Labeling phase
Date:
Operator:
Duration (hours):

Quality Control phase
Date:
Operator:

Cleaning and Storage phase
Date:
Operator:

Notes:

MIL-32 contacts	conductors	LEMO contacts	contact description
A	1.A		
B	1.B		
C	1.S		
D	2.A		
E	2.B		
F	2.S		
G	3.A		
H	3.B		
J	3.S		
K	4.A	K1.1	Lp
L	4.B	K1.2	Lp
M	4.S	K1.3	
N	5.A	K1.4	F1 +
P	5.B	K1.5	F1 -
R	5.S	K1.8	
S	6.A	K1.6	F2 +
T	6.B	K1.7	F2 -
U	6.S	K1.18	
V	7.A	K1.9	FC sx
W	7.B	K1.11	FC dx
X	7.S	K1.10	FC com
Y	8.A	K1.12	fbk
Z	8.B	K1.13	fbk
a	8.S	K1.14	
b	9.A	K1.15	Ls
c	9.B	K1.16	Ls
d	9.S	K1.17	

**cable L** (vacuum side)

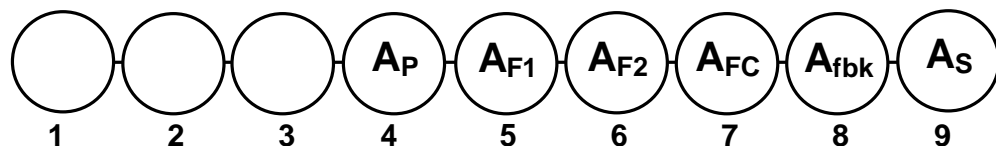
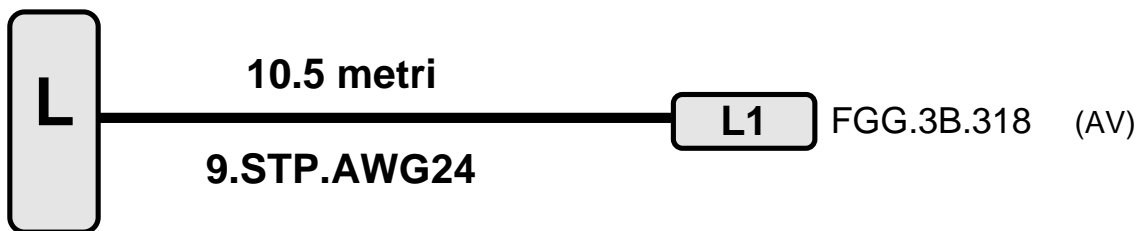

Cutting and Stripping phase
Date:
Operator:
Reel:

Crimping and Labeling phase
Date:
Operator:
Duration (hours):

Quality Control phase
Date:
Operator:

Cleaning and Storage phase
Date:
Operator:

Notes:

MIL-32 contacts	conductors	LEMO contacts	contact description	
A	1.A			
B	1.B			
C	1.S			
D	2.A			
E	2.B			
F	2.S			
G	3.A			
H	3.B			
J	3.S			
K	4.A	L1.1	Lp	1
L	4.B	L1.2	Lp	2
M	4.S	L1.3		3
N	5.A	L1.4	F1 +	
P	5.B	L1.5	F1 -	
R	5.S	L1.8		
S	6.A	L1.6	F2 +	
T	6.B	L1.7	F2 -	
U	6.S	L1.18		
V	7.A	L1.9	FC sx	
W	7.B	L1.11	FC dx	
X	7.S	L1.10	FC com	
Y	8.A	L1.12	fbk	4
Z	8.B	L1.13	fbk	5
a	8.S	L1.14		6
b	9.A	L1.15	Ls	7
c	9.B	L1.16	Ls	8
d	9.S	L1.17		9

**cable M (vacuum side)**

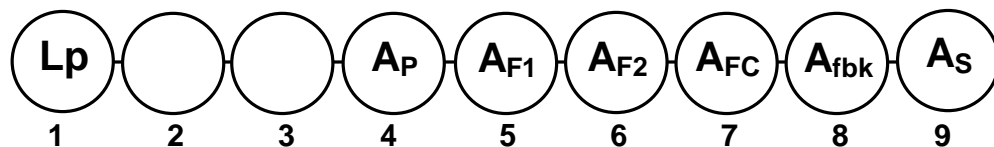
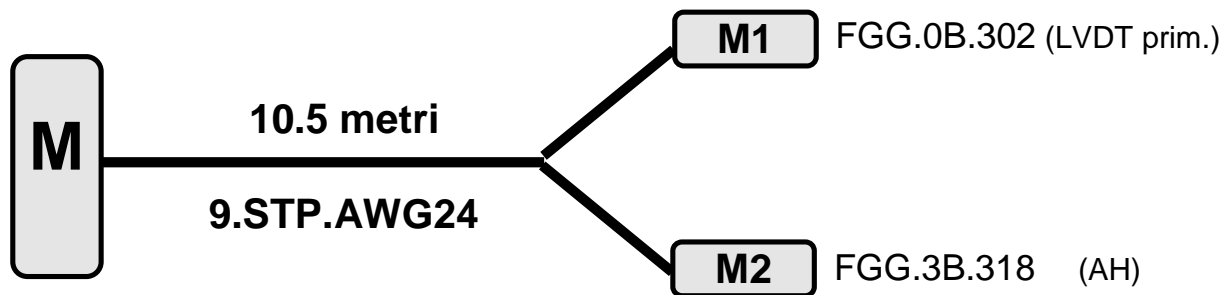

Cutting and Stripping phase
Date:
Operator:
Reel:

Crimping and Labeling phase
Date:
Operator:
Duration (hours):

Quality Control phase
Date:
Operator:

Cleaning and Storage phase
Date:
Operator:

Notes:
Diramare a 60 cm

MIL-32 contacts	conductors	LEMO contacts	contact description
A	1.A	M1.1	Lp
B	1.B	M1.2	Lp
C	1.S	n.c.	
D	2.A		
E	2.B		
F	2.S		
G	3.A		
H	3.B		
J	3.S		
K	4.A	M2.1	Lp
L	4.B	M2.2	Lp
M	4.S	M2.3	
N	5.A	M2.4	F1 +
P	5.B	M2.5	F1 -
R	5.S	M2.8	
S	6.A	M2.6	F2 +
T	6.B	M2.7	F2 -
U	6.S	M2.18	
V	7.A	M2.9	FC sx
W	7.B	M2.11	FC dx
X	7.S	M2.10	FC com
Y	8.A	M2.12	fbk
Z	8.B	M2.13	fbk
a	8.S	M2.14	
b	9.A	M2.15	Ls
c	9.B	M2.16	Ls
d	9.S	M2.17	

**cable N** (vacuum side)

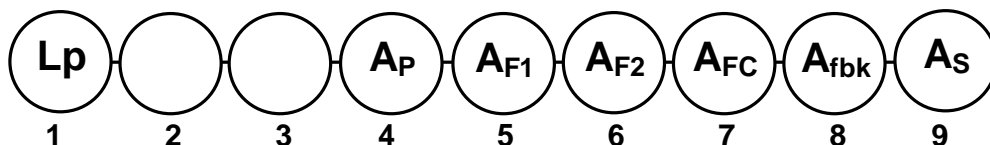
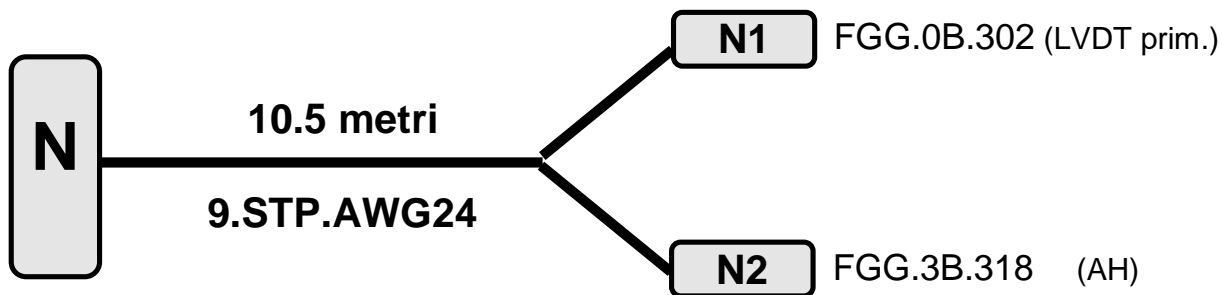

Cutting and Stripping phase
Date:
Operator:
Reel:

Crimping and Labeling phase
Date:
Operator:
Duration (hours):

Quality Control phase
Date:
Operator:

Cleaning and Storage phase
Date:
Operator:

Notes:
Diramare a 60 cm

MIL-32 contacts	conductors	LEMO contacts	contact description	
A	1.A	N1.1	Lp	1
B	1.B	N1.2	Lp	2
C	1.S	n.c.		3
D	2.A			
E	2.B			
F	2.S			
G	3.A			
H	3.B			
J	3.S			
K	4.A	N2.1	Lp	1
L	4.B	N2.2	Lp	2
M	4.S	N2.3		3
N	5.A	N2.4	F1 +	
P	5.B	N2.5	F1 -	
R	5.S	N2.8		
S	6.A	N2.6	F2 +	
T	6.B	N2.7	F2 -	
U	6.S	N2.18		
V	7.A	N2.9	FC sx	
W	7.B	N2.11	FC dx	
X	7.S	N2.10	FC com	
Y	8.A	N2.12	fbk	4
Z	8.B	N2.13	fbk	5
a	8.S	N2.14		6
b	9.A	N2.15	Ls	7
c	9.B	N2.16	Ls	8
d	9.S	N2.17		9



**cable O (vacuum side)**

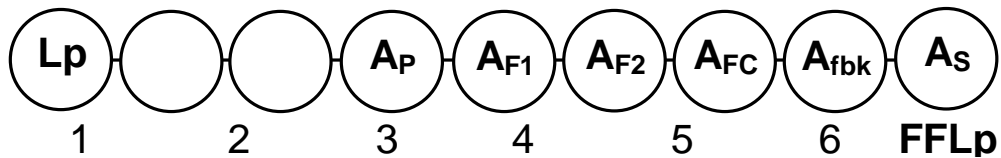
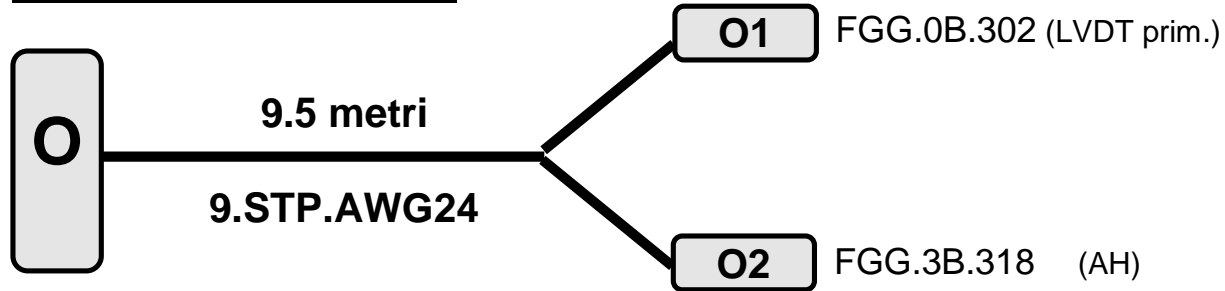

Cutting and Stripping phase
Date:
Operator:
Reel:

Crimping and Labeling phase
Date:
Operator:
Duration (hours):

Quality Control phase
Date:
Operator:

Cleaning and Storage phase
Date:
Operator:

Notes:
Diramare a 60 cm

MIL-32 contacts	conductors	LEMO contacts	contact description
<b>A</b>	1.A	O1.1	Lp
<b>B</b>	1.B	O1.2	Lp
<b>C</b>	1.S	n.c.	
<b>D</b>	2.A		
<b>E</b>	2.B		
<b>F</b>	2.S		
<b>G</b>	3.A		
<b>H</b>	3.B		
<b>J</b>	3.S		
<b>K</b>	4.A	O2.1	Lp
<b>L</b>	4.B	O2.2	Lp
<b>M</b>	4.S	O2.3	
<b>N</b>	5.A	O2.4	F1 +
<b>P</b>	5.B	O2.5	F1 -
<b>R</b>	5.S	O2.8	
<b>S</b>	6.A	O2.6	F2 +
<b>T</b>	6.B	O2.7	F2 -
<b>U</b>	6.S	O2.18	
<b>V</b>	7.A	O2.9	FC sx
<b>W</b>	7.B	O2.11	FC dx
<b>X</b>	7.S	O2.10	FC com
<b>Y</b>	8.A	O2.12	fbk
<b>Z</b>	8.B	O2.13	fbk
<b>a</b>	8.S	O2.14	
<b>b</b>	9.A	O2.15	Ls
<b>c</b>	9.B	O2.16	Ls
<b>d</b>	9.S	O2.17	

**Cable P** (vacuum side)

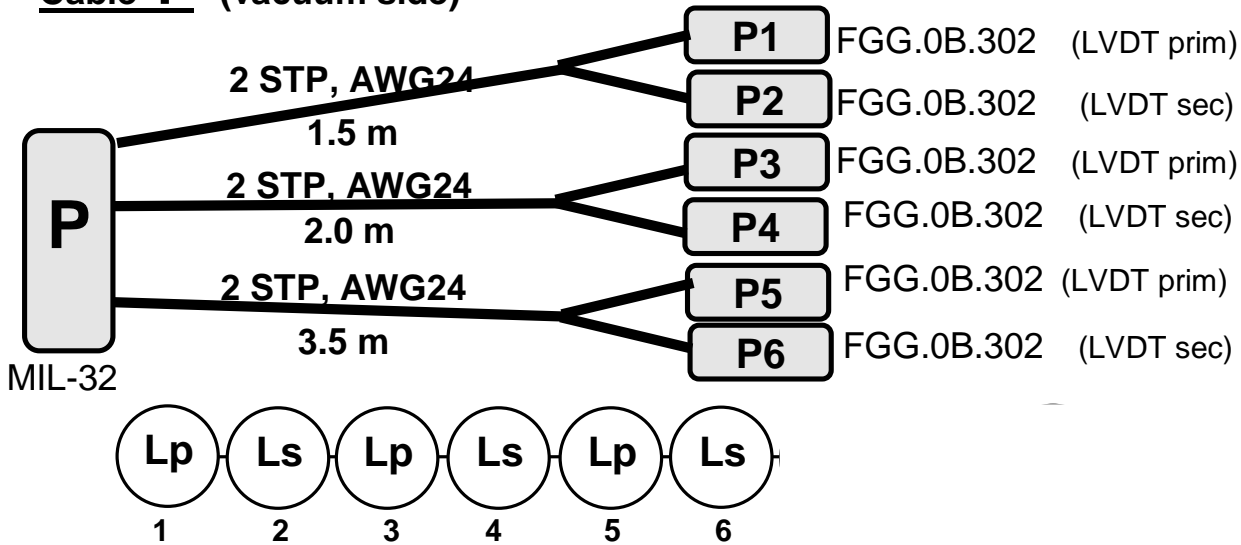

MIL-32 contacts	conductors	LEMO contacts	contact description
A	1.A	P1.1	Lp
B	1.B	P1.2	Lp
C	1.S	n.c.	
D	2.A	P2.3	Ls
E	2.B	P2.4	Ls
F	2.S	n.c.	
G	3.A	P3.5	Lp
H	3.B	P3.6	Lp
J	3.S	n.c.	
K	4.A	P4.7	Ls
L	4.B	P4.8	Ls
M	4.S	n.c.	
N	5.A	P5.1	Lp
P	5.B	P5.2	Lp
R	5.S	n.c.	
S	6.A	P6.1	Ls
T	6.B	P6.2	Ls
U	6.S	n.c.	

Cutting and Stripping phase
Data:
Operator:
Bobina di provenienza: <i>spezzoni</i>

Crimping and Labeling phase
Data:
Operator:
Tempo impiegato (ore):

Quality Control phase
Date: <i>25 jun 2015</i>
Operator: <i>Berni</i>

Cleaning and Storage phase
Data:
Operatore/i:

**Notes:**

Diramare opportunamente, considerando che gli LVDT sono disposti a 120 gradi lungo i piedi dell'IP.

**Cable Q** (vacuum side)

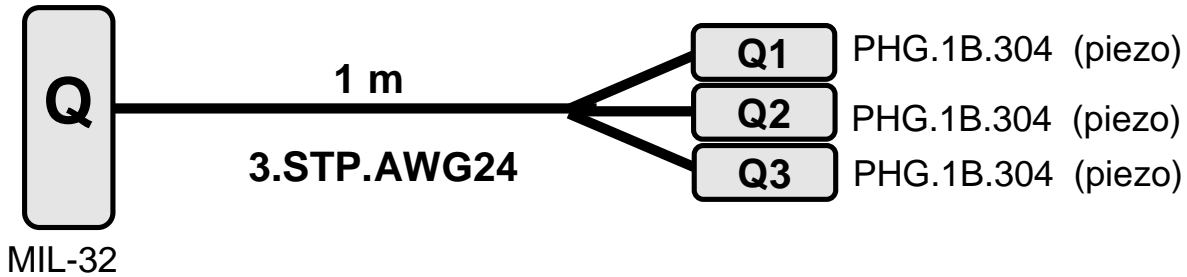

Cutting and Stripping phase
Data:
Operator:
Bobina di provenienza: <i>spezzoni</i>

Crimping and Labeling phase
Data:
Operator:
Tempo impiegato (ore):

Quality Control phase
Date: <i>25 jun 2015</i>
Operator: <i>Berni</i>

Cleaning and Storage phase
Data:
Operatore/i:

**Notes:**  
Creato per separare I piezo dagli LVDTs sul cavo P.

MIL-32 contacts	conductors	LEMO contacts	contact description
A			
B			
C			
D			
E			
F			
G			
H			
J			
K			
L			
M			
N			
P			
R			
S			
T			
U			
V	1.A	Q1.1	inner conductor
W	1.B	Q1.2	intermediate shield
X	1.S	Q1.3	outer shield
	n.c.	Q1.4	
Y	2.A	Q2.1	inner conductor
Z	2.B	Q2.2	intermediate shield
a	2.S	Q2.3	outer shield
	n.c.	Q2.4	
b	3.A	Q3.1	inner conductor
c	3.B	Q3.2	intermediate shield
d	3.S	Q3.3	outer shield
	n.c.	Q3.4	

**cable R (vacuum side)**

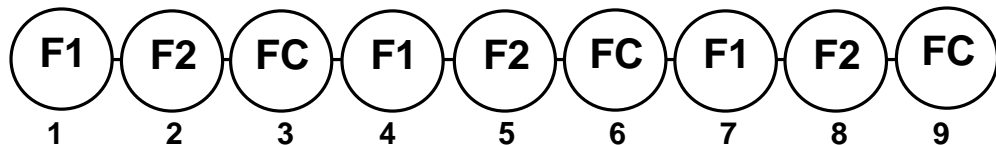
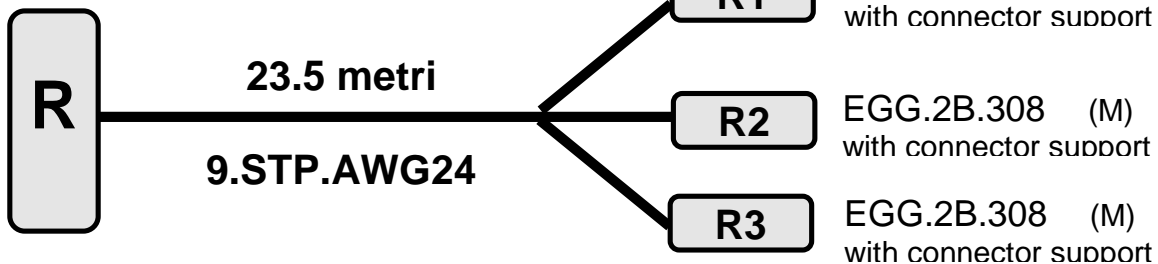

Cutting and Stripping phase
Date:
Operator: <i>F.Berni</i>
Reel: vecchio cavo R

Crimping and Labeling phase
Date:
Operator:
Duration (hours):

Quality Control phase
Date: <i>17apr15</i>
Operator: <i>F.Berni</i>

Cleaning and Storage phase
Date:
Operator:

Notes:
Modificato a Aprile 2015 (scorciato e con Lemo da pannello). Per lo schema del vecchio cavo R vedere la versione v3.
<b>NB:</b> inserire il lemo da pannello nell'apposito clamp a C.
Diramare a <u>20</u> cm

MIL-32 contacts	conductors	LEMO contacts	contact description
A	1.A	R1.1	F1 +
B	1.B	R1.2	F1 -
C	1.S	n.c.	
D	2.A	R1.3	F2 +
E	2.B	R1.4	F2 -
F	2.S	n.c.	
G	3.A	R1.5	FC cw
H	3.B	R1.6	FC ccw
J	3.S	R1.7	FC com
K	4.A	R2.1	F1 +
L	4.B	R2.2	F1 -
M	4.S	n.c.	
N	5.A	R2.3	F2 +
P	5.B	R2.4	F2 -
R	5.S	n.c.	
S	6.A	R2.5	FC cw
T	6.B	R2.6	FC ccw
U	6.S	R2.7	FC com
V	7.A	R3.1	F1 +
W	7.B	R3.2	F1 -
X	7.S	n.c.	
Y	8.A	R3.3	F2 +
Z	8.B	R3.4	F2 -
a	8.S	n.c.	
b	9.A	R3.5	FC cw
c	9.B	R3.6	FC ccw
d	9.S	R3.7	FC com

**cable S (vacuum side)**

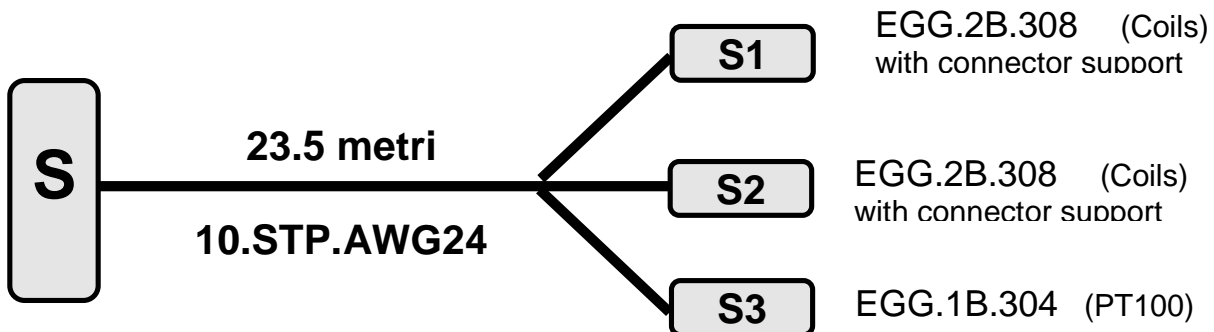

Cutting and Stripping phase
Date:
Operator:
Reel:

Crimping and Labeling phase
Date:
Operator:
Duration (hours):

Quality Control phase
Date: 03 jun 2015
Operator:

Cleaning and Storage phase
Date:
Operator:

Notes:
Rifatto ex-nov a maggio 2015. Per lo schema del vecchio cavo S vedere la versione v2. <b>NB:</b> inserire il lemo da pannello nell'apposito clamp a C. Diramare a <u>20 cm</u> ;

MIL-32 contacts	conductors	LEMO contacts	contact description
A	1.A	S1.1	C +
B	1.B	S1.2	C -
C	1.S	n.c.	
D	2.A	S1.3	C +
E	2.B	S1.4	C -
F	2.S	n.c.	
G	3.A	S1.5	C +
H	3.B	S1.6	C -
J	3.S	n.c.	
K	4.A	S1.7	C +
L	4.B	S1.8	C -
M	4.S	n.c.	
N	5.A	S2.1	C +
P	5.B	S2.2	C -
R	5.S	n.c.	
S	6.A	S2.3	C +
T	6.B	S2.4	C -
U	6.S	n.c.	
V	7.A	S2.5	C +
W	7.B	S2.6	C -
X	7.S	n.c.	
Y	8.A	S2.7	C +
Z	8.B	S2.8	C -
a	8.S	n.c.	
b	9.A	S3.1	spare
c	9.B	S3.2	spare
d	9.S		
e	10.A	S3.3	PT100 A+
f	10.B	S3.4	PT100 A-
g	10.S	n.c.	

## cable T (vacuum side)

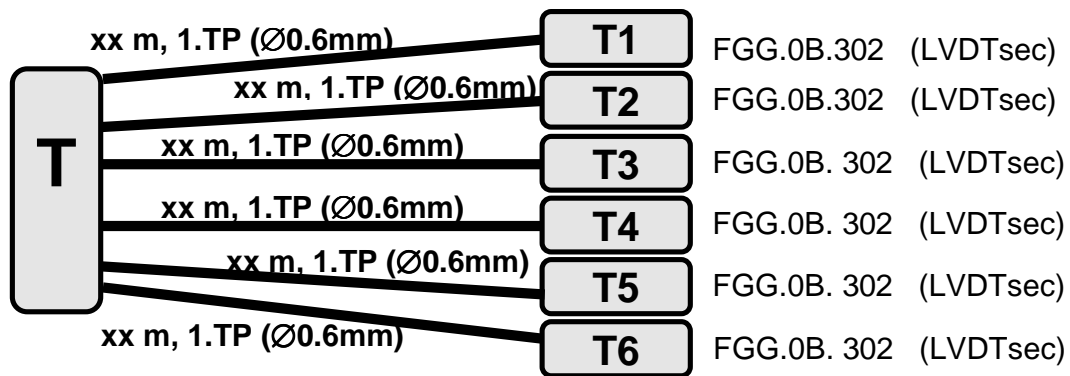

Cutting and Stripping phase
Date:
Operator:
Reel: #xx by MWS, AWG 24 HML

Crimping and Labeling phase
Date:
Operator:
Duration (hours):

Quality Control phase
Date:
Operator:

Cleaning and Storage phase
Date:
Operator:

### Notes:

It replaces the old cable T, made with a Gore cable (for the old scheme see version cable\_schemes\_v3)

The new one is standard solid wire, with Pyre enamel, double (heavy) insulation.

The bundle is xx cm long, and then is branched till the lemo connectors

MIL-32 contacts	conductors	LEMO contacts	contact description
A	1.A	T1.1	Ls
B	1.B	T1.2	Ls
C	n.c.	n.c.	
D	2.A	T2.1	Ls
E	2.B	T2.2	Ls
F	n.c.	n.c.	
G	3.A	T3.1	Ls
H	3.B	T3.2	Ls
J	n.c.	n.c.	
K	4.A	T4.1	Ls
L	4.B	T4.2	Ls
M	n.c.	n.c.	
N	5.A	T5.1	Ls
P	5.B	T5.2	Ls
R	n.c.	n.c.	
S	6.A	T6.1	Ls
T	6.B	T6.2	Ls
U	n.c.	n.c.	

**cable U** (vacuum side)

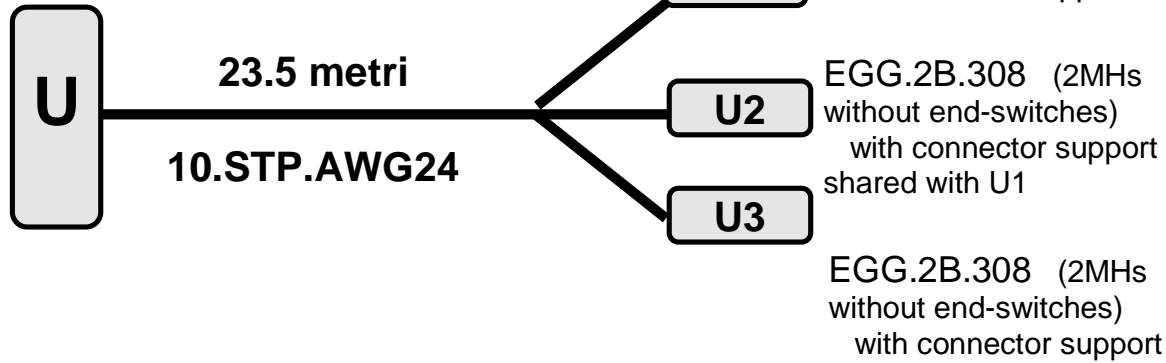

Cutting and Stripping phase
Date: 29may 2015
Operator: Berni
Reel:

Crimping and Labeling phase
Date: 29may 2015
Operator: Berni
Duration (hours):

Quality Control phase
Date: 04 jun 2015
Operator:

Cleaning and Storage phase
Date:
Operator:

Notes:
Creato ex-novo per AdV.
<b>NB: inserire il lemo da pannello nell'apposito clamp a C.</b>
Diramare a 20 cm

MIL-32 contacts	conductors	LEMO contacts	contact description
A	1.A	U1.1	RH +
B	1.B	U1.2	RH -
C	1.S	n.c.	
D	2.A	U1.3	RH +
E	2.B	U1.4	RH -
F	2.S	n.c.	
G	3.A	U2.1	F1 +
H	3.B	U2.2	F1 -
J	3.S	n.c.	
K	4.A	U2.3	F2 +
L	4.B	U2.4	F2 -
M	4.S	n.c.	
N	5.A	U2.5	F1 +
P	5.B	U2.6	F1 -
R	5.S	n.c.	
S	6.A	U2.7	F2 +
T	6.B	U2.8	F2 -
U	6.S	n.c.	
V	7.A	U3.1	F1 +
W	7.B	U3.2	F1 -
X	7.S	n.c.	
Y	8.A	U3.3	F2 +
Z	8.B	U3.4	F2 -
a	8.S	n.c.	
b	9.A	U3.5	F1 +
c	9.B	U3.6	F1 -
d	9.S	n.c.	
e	10.A	U3.7	F2 +
f	10.B	U3.8	F2 -
g	10.S	n.c.	

**cable V** (Vacuum side)

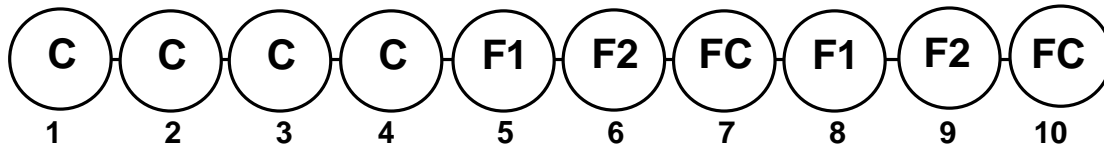
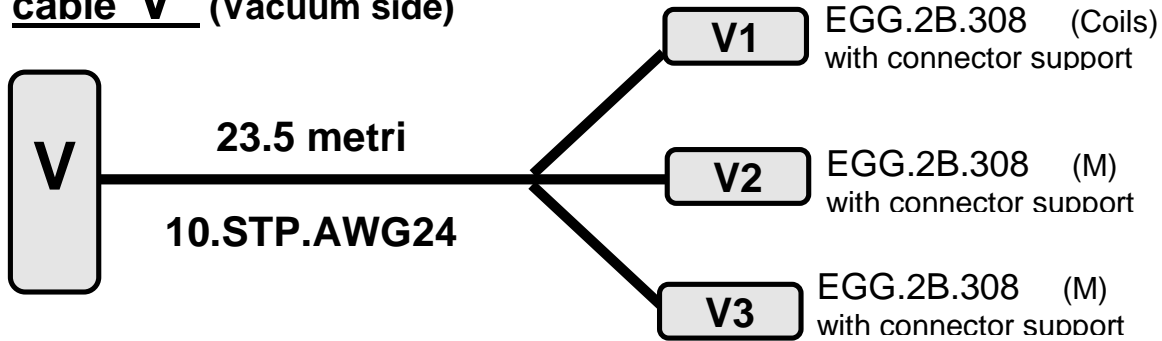

Cutting and Stripping phase
Date: 24apr15
Operator: F.Berni
Reel:)

Crimping and Labeling phase
Date: 24apr15
Operator: F.Berni
Duration (hours):

Quality Control phase
Date: 24apr15
Operator: F.Berni

Cleaning and Storage phase
Date:
Operator:

**Notes:**  
 Rifatto ex-novo a Aprile 2015. Per lo schema del vecchio cavo V vedere la versione v3.  
**NB:** inserire il lemo da pannello nell'apposito clamp a C.  
 Diramare a 20 cm

MIL-32 contacts	conductors	LEMO contacts	contact description
A	1.A	V1.1	C +
B	1.B	V1.2	C -
C	1.S	n.c.	
D	2.A	V1.3	C +
E	2.B	V1.4	C -
F	2.S	n.c.	
G	3.A	V1.5	C +
H	3.B	V1.6	C -
J	3.S	n.c.	
K	4.A	V1.7	C +
L	4.B	V1.8	C -
M	4.S	n.c.	
N	5.A	V2.1	F1 +
P	5.B	V2.2	F1 -
R	5.S	n.c.	
S	6.A	V2.3	F2 +
T	6.B	V2.4	F2 -
U	6.S	n.c.	
V	7.A	V2.5	FC cw
W	7.B	V2.6	FC ccw
X	7.S	V2.7	FC com
Y	8.A	V3.1	F1 +
Z	8.B	V3.2	F1 -
a	8.S	n.c.	
b	9.A	V3.3	F2 +
c	9.B	V3.4	F2 -
d	9.S	n.c.	
e	10.A	V3.5	FC cw
f	10.B	V3.6	FC ccw
g	10.S	V3.7	FC com



## cable W (vacuum side)

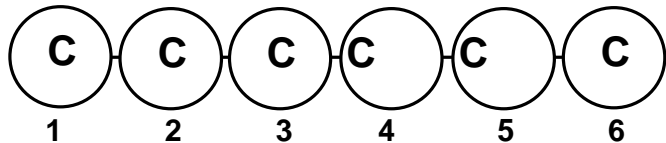
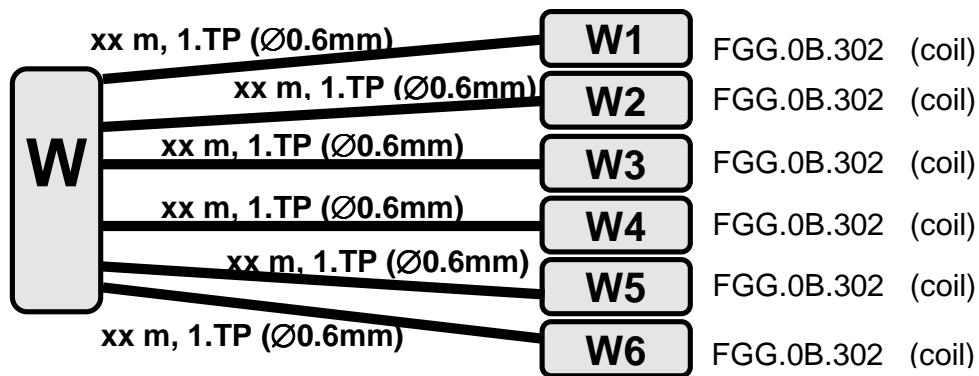

Cutting and Stripping phase	Crimping and Labeling phase
Date:	Date:
Operator:	Operator:
Reel: #xx by MWS, AWG 24 HML	Duration (hours):
Quality Control phase	Cleaning and Storage phase
Date:	Date:
Operator:	Operator:

### Notes:

It replaces the old cable W, that was made with a Gore cable (for the old scheme see version cable\_schemes\_v1).

The new one is standard solid wire, with Pyre enamel, double (heavy) insulation.

The bundle is xx cm long, and then is branched till the lemo connectors

MIL-32 contacts	conductors	LEMO contacts	contact description
<b>A</b>	1.A	W1.1	C +
<b>B</b>	1.B	W1.2	C -
<b>C</b>	n.c.	n.c.	
<b>D</b>	2.A	W2.1	C +
<b>E</b>	2.B	W2.2	C -
<b>F</b>	n.c.	n.c.	
<b>G</b>	3.A	W3.1	C +
<b>H</b>	3.B	W3.2	C -
<b>J</b>	n.c.	n.c.	
<b>K</b>	4.A	W4.1	C +
<b>L</b>	4.B	W4.2	C -
<b>M</b>	n.c.	n.c.	
<b>N</b>	5.A	W5.1	C +
<b>P</b>	5.B	W5.2	C -
<b>R</b>	n.c.	n.c.	
<b>S</b>	6.A	W6.1	C +
<b>T</b>	6.B	W6.2	C -
<b>U</b>	n.c.	n.c.	

**cable Z (Vacuum side)**

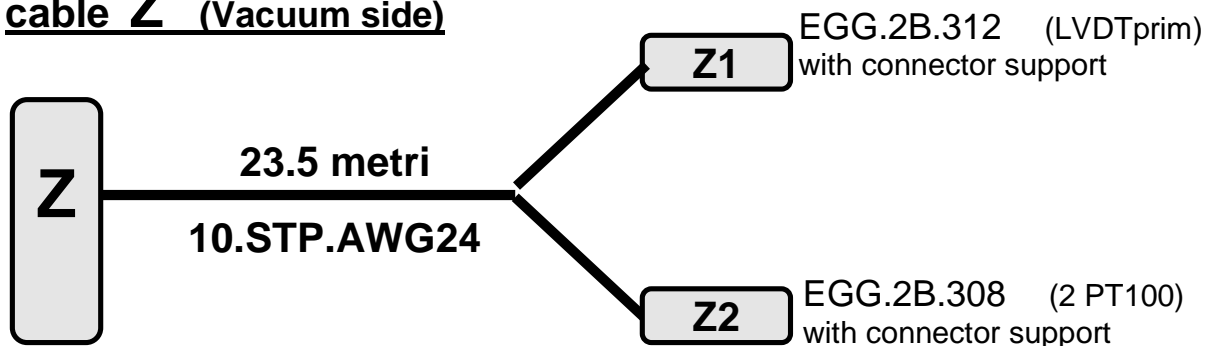

Cutting and Stripping phase
Date:
Operator:
Reel: <i>nuovo</i>

Crimping and Labeling phase
Date:
Operator:
Duration (hours):

Quality Control phase
Date: <i>10 jun 2015</i>
Operator:

Cleaning and Storage phase
Date:
Operator:

Notes:
Nuovo, creato per AdV. Per collegare i primari degli attuatori/LVDT del F#. Usato anche per i sensori di temperatura del RH e del payload. <b>NB:</b> inserire il lemo da pannello nell'apposito clamp a C. Diramare a 20 cm

MIL-32 contacts	conductors	ODU / LEMO contacts	contact description
A	1.A	Z1.1	Lp
B	1.B	Z1.2	Lp
C	1.S	n.c.	
D	2.A	Z1.3	Lp
E	2.B	Z1.4	Lp
F	2.S	n.c.	
G	3.A	Z1.5	Lp
H	3.B	Z1.6	Lp
J	3.S	n.c.	
K	4.A	Z1.7	Lp
L	4.B	Z1.8	Lp
M	4.S	n.c.	
N	5.A	Z1.9	Lp
P	5.B	Z1.10	Lp
R	5.S	n.c.	
S	6.A	Z1.11	Lp
T	6.B	Z1.12	Lp
U	6.S	n.c.	
V	7.A	Z2.1	PT100 V+
W	7.B	Z2.2	PT100 V-
X	7.S	n.c.	
Y	8.A	Z2.3	PT100 A+
Z	8.B	Z2.4	PT100 A-
a	8.S	n.c.	
b	9.A	Z2.5	PT100 V+
c	9.B	Z2.6	PT100 V-
d	9.S	n.c.	
e	10.A	Z2.7	PT100 A+
f	10.B	Z2.8	PT100 A-
g	10.S	n.c.	

