

CABLE ASSEMBLY SCHEMES

for *North Input* cabling

Change History

Version	Date	Changes/Reasons
v1	2000	initial suspension cabling
v2	2003	added cabling of sensors and actuators on Filter #7
v3r0	4mar08	added TCS cabling
v3r1	22feb10	Added 2 temperature sensors close to the RefMass

INDEX

Informazioni generali.....	2
Identificazione componenti.....	2
Legenda	3
LEMO pinout of the main devices	3
CABLE A (VACUUM SIDE)	4
CABLE B (VACUUM SIDE)	5
CABLE C (VACUUM SIDE)	6
CABLE D (VACUUM SIDE)	7
CABLE E (VACUUM SIDE).....	8
CABLE F (VACUUM SIDE).....	9
CABLE G (VACUUM SIDE)	10
CABLE H (VACUUM SIDE)	11
CABLE J (VACUUM SIDE)	12
CABLE K (VACUUM SIDE)	13
CABLE L (VACUUM SIDE).....	14
CABLE M (VACUUM SIDE)	15
CABLE N (VACUUM SIDE)	16
CABLE O (VACUUM SIDE)	17
CABLE R (VACUUM SIDE)	18
CABLE S (VACUUM SIDE).....	19
CABLE T (VACUUM SIDE).....	20
CABLE U (VACUUM SIDE)	20
CABLE V (VACUUM SIDE).....	222
CABLE W (VACUUM SIDE).....	23
CABLE X (VACUUM SIDE).....	24

Informazioni generali

Ciascun spezzone di cavo va terminato ad una estremità da un connettore circolare 32 poli (tipo presa), all'altra estremità con uno o più connettori Lemo multipolari (generalmente tipo spina). I cavi sono del tipo:

- cavo piatto a 18 conduttori trefolati AWG 24, isolati in goretex, a coppie ritorte e schermate singolarmente (cavo STP).
- cavo assemblato in lab a conduttori solidi AWG 18, isolati in polimide, a coppie ritorte (cavo TP).
- cavo assemblato in lab a conduttori solidi AWG 22, isolati in polimide, a triplette ritorte (cavo TT).

Identificazione componenti

- Ciascun cavo è identificato da una lettera dell'alfabeto.
- Il tipo di cavo utilizzato e' indicato in prossimità' del disegno: la sigla comprende il numero di coppie di conduttori, il tipo di schermatura (STP, TP, TT), la sezione (es. AWG24). Es.: la sigla **9.STP.AWG24** specifica un tipo di cavo avente 18 conduttori intrecciati e schermati a coppie, di sezione AWG24
- Ciascun conduttore di un cavo STP è identificato da un numero cardinale relativo alla coppia (**1** per la coppia bianco/rossa a seguire fino ad **9** per le altre coppie bianco/gialle), da una lettera (**A** per il conduttore con isolante a strisce rosse, **B** per l'altro conduttore della coppia, **S** per la calza) (es. la calza nella terza coppia, è identificata da **3.S**).
- Ciascun connettore Lemo è identificato da due caratteri: il primo è la lettera del cavo sul quale è saldato il connettore, il secondo è un numero cardinale, che va da 1 al n. max di connettori Lemo sullo stesso cavo (es. per il cavo **B** terminato da due Lemo, essi sono identificati da **B1** e **B2**)
- I contatti di ciascun connettore Lemo sono identificati dal nome dell connettore, seguito dal numero del contatto indicato sull'isolante del connettore (es. il contatto¹ n. 4 che si trova sul connettore Lemo **B3** e' identificato da **B3.4**)
- I contatti di ciascun connettore circolare a 32 poli sono identificati da lettere (A÷Z, a÷j). Per quelli interni vale il pinout serigrafato sul retro dell'isolante, per quelli esterni vale il pinout standard

¹ Nel caso di conduttori Lemo, il contatto n. 1 e' quello col semicerchio bianco, i successivi sono quelli lungo la linea bianca che parte dal contatto n. 1.

Legenda

F1 +	motore, fase 1, positivo
F1 -	motore, fase 1, negativo
F2 +	motore, fase 2, positivo
F2 -	motore, fase 2, negativo
FC fw	motore, fine corsa, forward
FC bw	motore, fine corsa, backard
FC com	motore, fine corsa, comune
RST up	motore, reostato, terminale superiore
RST down	motore, reostato, terminale inferiore
RST com	motore, reostato, comune o cursore
TP sx +	thermal probe, sinistro, positivo
TP sx -	thermal probe, sinistro, negativo
TP dx +	thermal probe, destro, positivo
TP dx -	thermal probe, destro, negativo
Ls	LVDT, secondario
Lp	LVDT, primario
C +	coil attuatore, positivo
C -	coil attuatore, negativo
fbk	accelerometro, feedback
V _H	Voltmetrico alto
V _L	Voltmetrico basso
A _H	Amperometrico alto
A _L	Amperometrico basso

LEMO pinout of the main devices

ACCELEROMETER	
LEMO contacts	Contact descript.
1	Lp
2	Lp
3	
4	F1 +
5	F1 -
6	F2 +
7	F2 -
8	
9	FC sx
11	FC dx
10	FC com
12	fbk
13	fbk
14	
15	Ls
16	Ls
17	
18	

LVDT	
LEMO contacts	Contact descript.
1	Lp +
2	Lp -
3	Ls +
4	Ls -

COIL	
LEMO contacts	Contact descript.
1	C +
2	C -

MOTOR		
LEMO contacts	Contact descript.	UTG 12p contacts
1	F1 +	A
2	F1 -	B
3	F1 shield	C
4	F2 +	D
5	F2 -	E
6	F2 shield	F
7	FC fw	G
8	FC bw	H
	FC com	J
	n.c.	

TILTMETER		
LEMO contacts	Contact descript.	UTG 12p contacts
1	1 +	A
2	1 -	B
3	E1	C
4	2 +	D
5	2 -	E
6	E2	F
7	n.c.	
8	n.c.	

cable B (vacuum side)

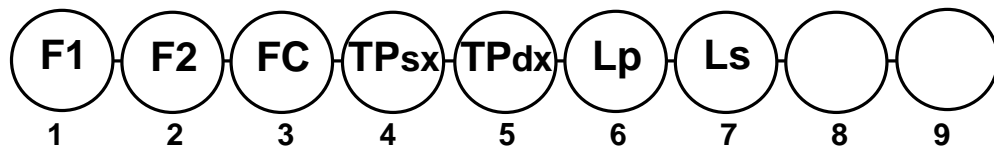
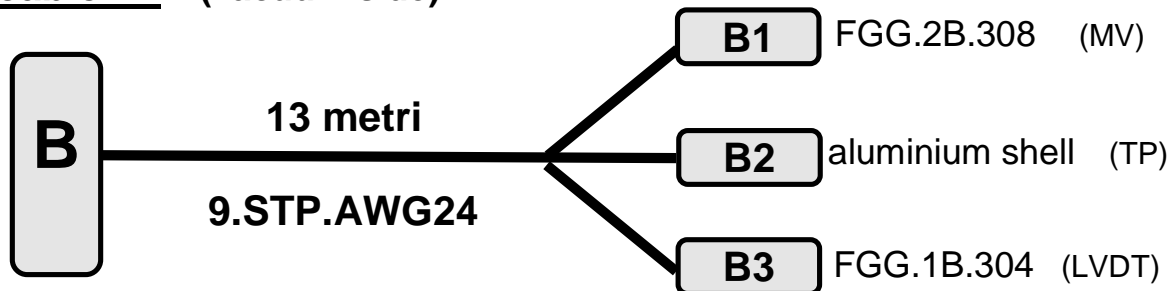

Cutting and Stripping phase
Date:
Operator:
Reel:

Crimping and Labeling phase
Date:
Operator:
Duration (hours):

Quality Control phase
Date:
Operator:

Cleaning and Storage phase
Date:
Operator:

Notes:
Diramare a 60 cm

MIL-32 contacts	conductors	LEMO contacts	contact description
A	1.A	B1.1	F1 +
B	1.B	B1.2	F1 -
C	1.S	n.c.	
D	2.A	B1.3	F2 +
E	2.B	B1.4	F2 -
F	2.S	n.c.	
G	3.A	B1.5	FC fw
H	3.B	B1.6	FC bw
J	3.S	B1.7	FC com
K	4.A	B2	TP sx +
L	4.B	B2	TP sx -
M	4.S	n.c.	
N	5.A	B2	TP dx +
P	5.B	B2	TP dx -
R	5.S	n.c.	
S	6.A	B3.1	Lp
T	6.B	B3.2	Lp
U	6.S	n.c.	
V	7.A	B3.3	Ls
W	7.B	B3.4	Ls
X	7.S	n.c.	
Y	8.A		
Z	8.B		
a	8.S		
b	9.A		
c	9.B		
d	9.S		

cable C (vacuum side)

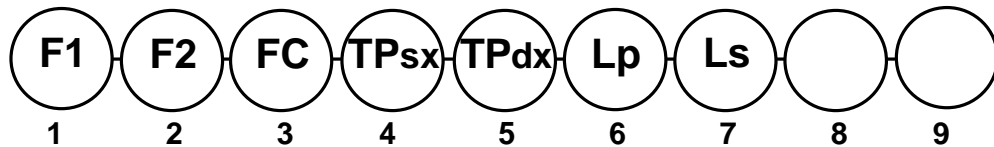
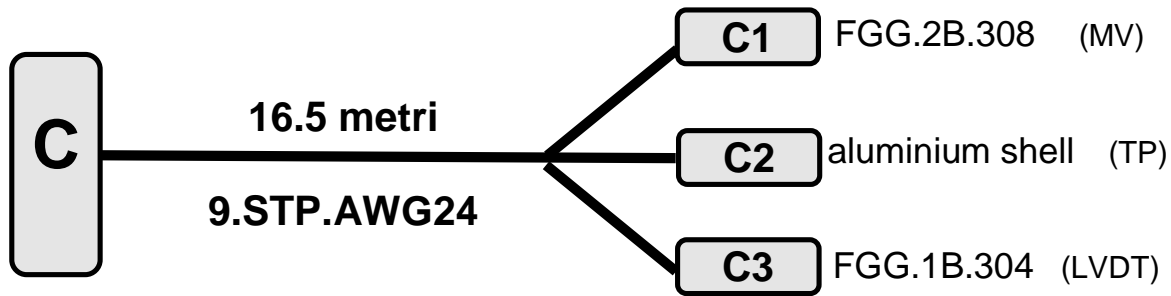

Cutting and Stripping phase
Date:
Operator:
Reel:

Crimping and Labeling phase
Date:
Operator:
Duration (hours):

Quality Control phase
Date:
Operator:

Cleaning and Storage phase
Date:
Operator:

Notes:
Diramare a 60 cm

MIL-32 contacts	conductors	LEMO contacts	contact description
A	1.A	C1.1	F1 +
B	1.B	C1.2	F1 -
C	1.S	n.c.	
D	2.A	C1.3	F2 +
E	2.B	C1.4	F2 -
F	2.S	n.c.	
G	3.A	C1.5	FC fw
H	3.B	C1.6	FC bw
J	3.S	C1.7	FC com
K	4.A	C2	TP sx +
L	4.B	C2	TP sx -
M	4.S	n.c.	
N	5.A	C2	TP dx +
P	5.B	C2	TP dx -
R	5.S	n.c.	
S	6.A	C3.1	Lp
T	6.B	C3.2	Lp
U	6.S	n.c.	
V	7.A	C3.3	Ls
W	7.B	C3.4	Ls
X	7.S	n.c.	
Y	8.A		
Z	8.B		
a	8.S		
b	9.A		
c	9.B		
d	9.S		

cable D (vacuum side)

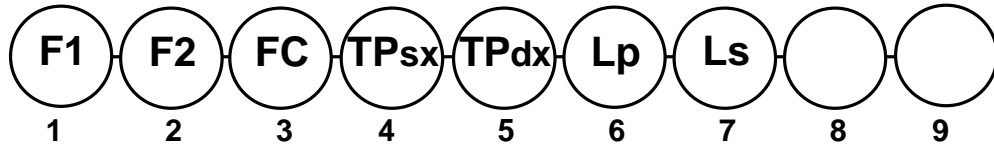
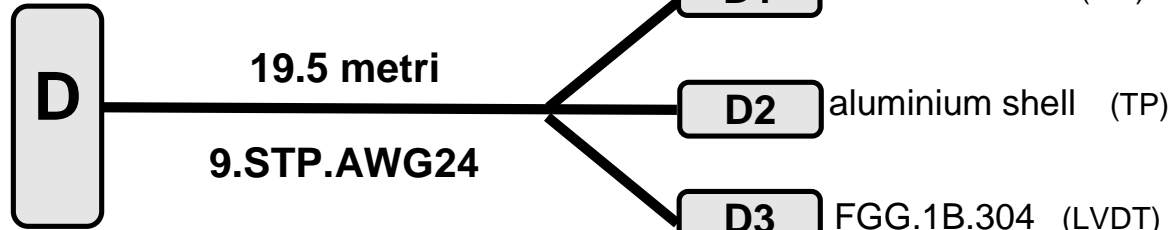

Cutting and Stripping phase
Date:
Operator:
Reel:

Crimping and Labeling phase
Date:
Operator:
Duration (hours):

Quality Control phase
Date:
Operator:

Cleaning and Storage phase
Date:
Operator:

Notes:
Diramare a 60 cm

MIL-32 contacts	conductors	LEMO contacts	contact description
A	1.A	D1.1	F1 +
B	1.B	D1.2	F1 -
C	1.S	n.c.	
D	2.A	D1.3	F2 +
E	2.B	D1.4	F2 -
F	2.S	n.c.	
G	3.A	D1.5	FC fw
H	3.B	D1.6	FC bw
J	3.S	D1.7	FC com
K	4.A	D2	TP sx +
L	4.B	D2	TP sx -
M	4.S	n.c.	
N	5.A	D2	TP dx +
P	5.B	D2	TP dx -
R	5.S	n.c.	
S	6.A	D3.1	Lp
T	6.B	D3.2	Lp
U	6.S	n.c.	
V	7.A	D3.3	Ls
W	7.B	D3.4	Ls
X	7.S	n.c.	
Y	8.A		
Z	8.B		
a	8.S		
b	9.A		
c	9.B		
d	9.S		

cable E (vacuum side)

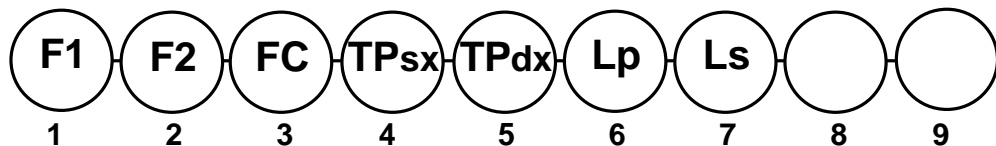
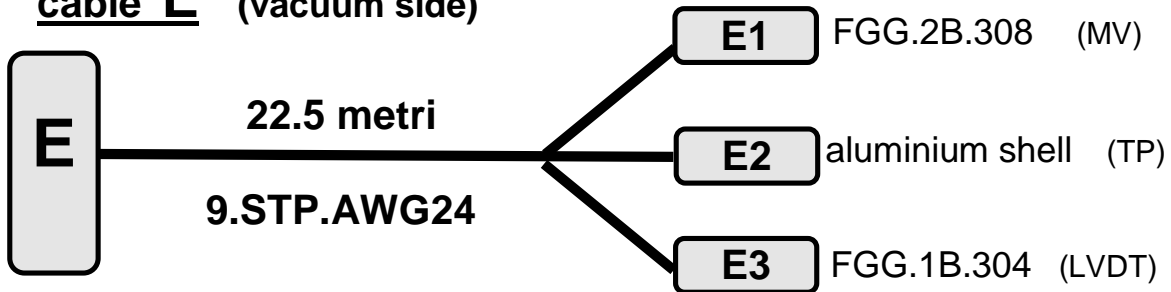

Cutting and Stripping phase
Date:
Operator:
Reel:

Crimping and Labeling phase
Date:
Operator:
Duration (hours):

Quality Control phase
Date:
Operator:

Cleaning and Storage phase
Date:
Operator:

Notes:
Diramare a 60 cm

MIL-32 contacts	conductors	LEMO contacts	contact description
A	1.A	E1.1	F1 +
B	1.B	E1.2	F1 -
C	1.S	n.c.	
D	2.A	E1.3	F2 +
E	2.B	E1.4	F2 -
F	2.S	n.c.	
G	3.A	E1.5	FC fw
H	3.B	E1.6	FC bw
J	3.S	E1.7	FC com
K	4.A	E2	TP sx +
L	4.B	E2	TP sx -
M	4.S	n.c.	
N	5.A	E2	TP dx +
P	5.B	E2	TP dx -
R	5.S	n.c.	
S	6.A	E3.1	Lp
T	6.B	E3.2	Lp
U	6.S	n.c.	
V	7.A	E3.3	Ls
W	7.B	E3.4	Ls
X	7.S	n.c.	
Y	8.A		
Z	8.B		
a	8.S		
b	9.A		
c	9.B		
d	9.S		

cable F (vacuum side)

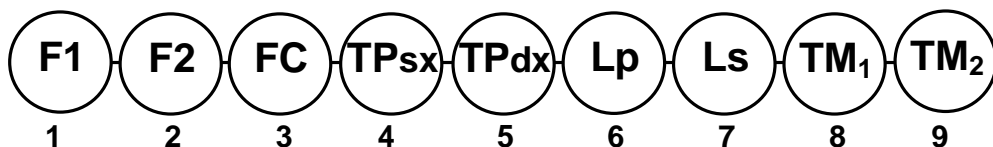
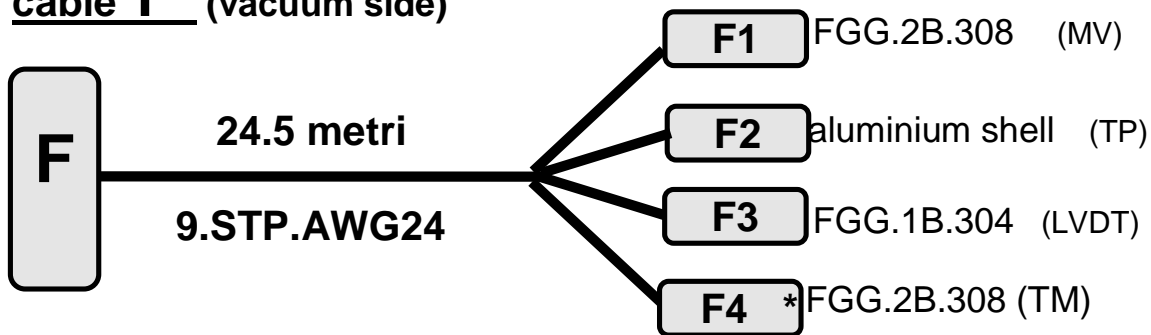

Cutting and Stripping phase
Date: 17 feb 00
Operator: Ceccanti
Reel: N

Crimping and Labeling phase
Date: 17 feb 00
Operator: Ceccanti
Duration (hours):

Quality Control phase
Date: 17 feb 00
Operator: Ceccanti

Cleaning and Storage phase
Date:
Operator:

Notes:
Diramare a 60 cm
ATTENZIONE: non testare mai il tiltometro con il multimetro (si danneggia!!)
* upgraded during May 2003 (by Nenci)

MIL-32 contacts	conductors	LEMO contacts	contact description
A	1.A	F1.1	F1 +
B	1.B	F1.2	F1 -
C	1.S	n.c.	
D	2.A	F1.3	F2 +
E	2.B	F1.4	F2 -
F	2.S	n.c.	
G	3.A	F1.5	FC fw
H	3.B	F1.6	FC bw
J	3.S	F1.7	FC com
K	4.A	F2	TP sx +
L	4.B	F2	TP sx -
M	4.S	n.c.	
N	5.A	F2	TP dx +
P	5.B	F2	TP dx -
R	5.S	n.c.	
S	6.A	F3.1	Lp
T	6.B	F3.2	Lp
U	6.S	n.c.	
V	7.A	F3.3	Ls
W	7.B	F3.4	Ls
X	7.S	n.c.	
Y	8.A	F4.1	1+ *
Z	8.B	F4.2	1- *
a	8.S	F4.3	E1 *
b	9.A	F4.4	2+ *
c	9.B	F4.5	2- *
d	9.S	F4.6	E2 *

cable G (vacuum side)

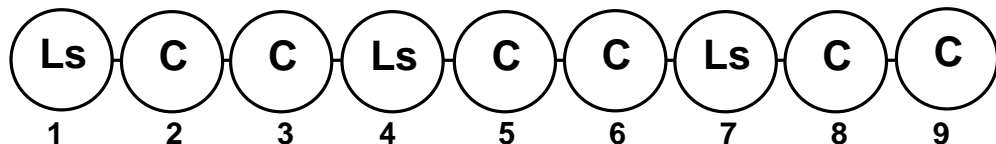
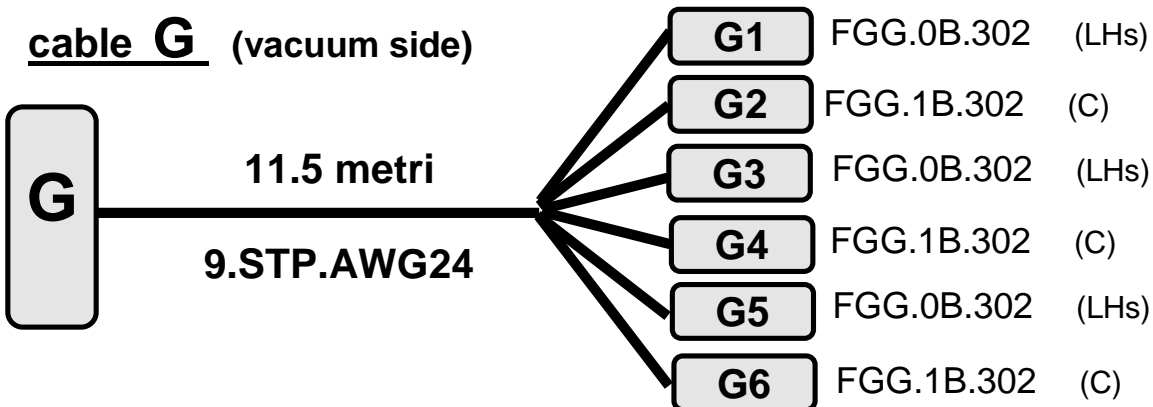

Cutting and Stripping phase
Date:
Operator:
Reel:

Crimping and Labeling phase
Date:
Operator:
Duration (hours):

Quality Control phase
Date:
Operator:

Cleaning and Storage phase
Date:
Operator:

Notes:

Diramare a gruppi (G1+G2, G3+G4, G5+G6) di 2.5 metri;
 Scorciare G3+G4 di 1.5 metri rispetto ai 11.5 metri totali;
 Ponticelli su MIL-32.

MIL-32 contacts	conductors	LEMO contacts	contact description
A	1.A	G1.1	Ls
B	1.B	G1.2	Ls
C	1.S	n.c.	
D	2.A	G2.1	C +
E	2.B	G2.2	C -
F	2.S	n.c.	
G	3.A	G2.1	C +
H	3.B	G2.2	C -
J	3.S	n.c.	
K	4.A	G3.1	Ls
L	4.B	G3.2	Ls
M	4.S	n.c.	
N	5.A	G4.1	C +
P	5.B	G4.2	C -
R	5.S	n.c.	
S	6.A	G4.1	C +
T	6.B	G4.2	C -
U	6.S	n.c.	
V	7.A	G5.1	Ls
W	7.B	G5.2	Ls
X	7.S	n.c.	
Y	8.A	G6.1	C +
Z	8.B	G6.2	C -
a	8.S	n.c.	
b	9.A	G6.1	C +
c	9.B	G6.2	C -
d	9.S	n.c.	

cable H (vacuum side)

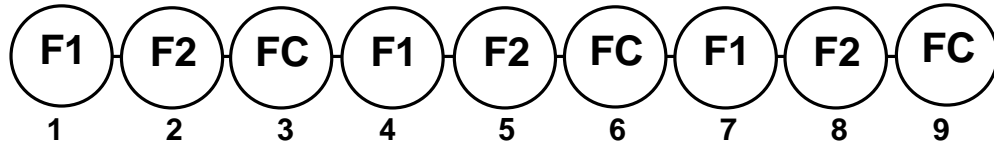
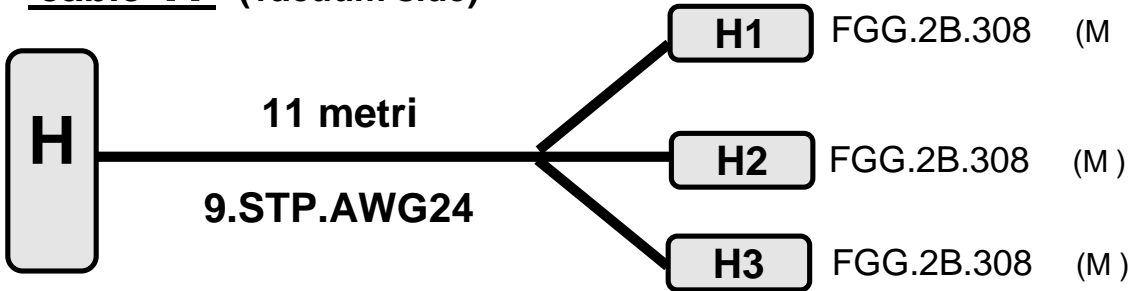

Cutting and Stripping phase
Date:
Operator:
Reel:

Crimping and Labeling phase
Date:
Operator:
Duration (hours):

Quality Control phase
Date:
Operator:

Cleaning and Storage phase
Date:
Operator:

Notes:
Diramare di <u>2,5 metri</u> ;
Scorciare H2 di <u>1.5 metri</u> .

MIL-32 contacts	conductors	LEMO contacts	contact description
A	1.A	H1.1	F1 +
B	1.B	H1.2	F1 -
C	1.S	n.c.	
D	2.A	H1.3	F2 +
E	2.B	H1.4	F2 -
F	2.S	n.c.	
G	3.A	H1.5	FC fw
H	3.B	H1.6	FC bw
J	3.S	H1.7	FC com
K	4.A	H2.1	F1 +
L	4.B	H2.2	F1 -
M	4.S	n.c.	
N	5.A	H2.3	F2 +
P	5.B	H2.4	F2 -
H	5.S	n.c.	
S	6.A	H2.5	FC fw
T	6.B	H2.6	FC bw
U	6.S	H2.7	FC com
V	7.A	H3.1	F1 +
W	7.B	H3.2	F1 -
X	7.S	n.c.	
Y	8.A	H3.3	F2 +
Z	8.B	H3.4	F2 -
a	8.S	n.c.	
b	9.A	H3.5	FC fw
c	9.B	H3.6	FC bw
d	9.S	H3.7	FC com

cable J (vacuum side)

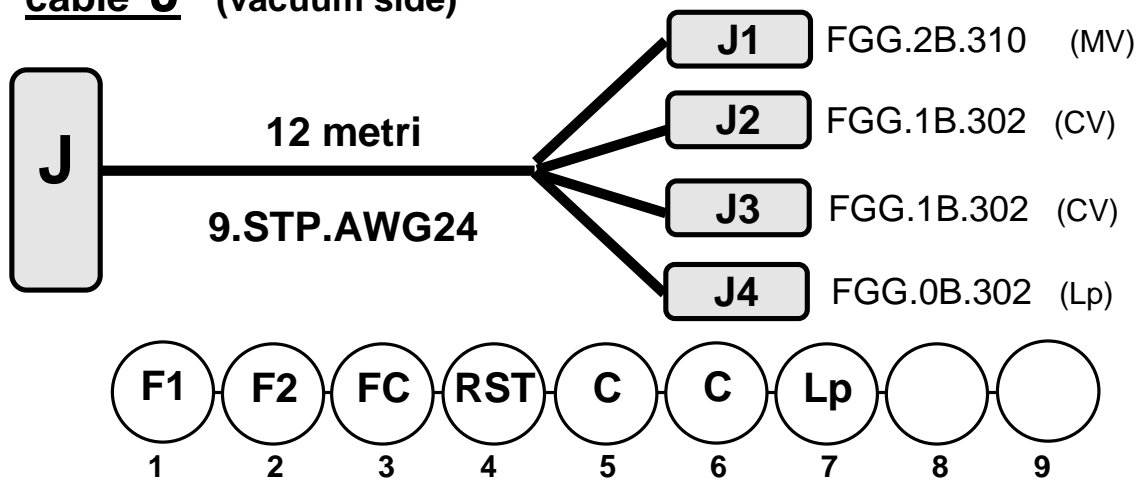

Cutting and Stripping phase
Date:
Operator:
Reel:

Crimping and Labeling phase
Date:
Operator:
Duration (hours):

Quality Control phase
Date:
Operator:

Cleaning and Storage phase
Date:
Operator:

Notes:

Diramare a 100 cm tra J2 e J3;
 Diramare J3 e J4 di 25 cm;
 Scorciare J1 di 100 cm;
 Scorciare J2 di 20 cm.

RST e' il reostato, usato come sensore di posizione dell'hoist.

MIL-32 contacts	conductors	LEMO contacts	contact description
A	1.A	J1.1	F1 +
B	1.B	J1.2	F1 -
C	1.S	n.c.	
D	2.A	J1.3	F2 +
E	2.B	J1.4	F2 -
F	2.S	n.c.	
G	3.A	J1.5	FC fw
H	3.B	J1.6	FC bw
J	3.S	J1.7	FC com
K	4.A	J1.8	RST down
L	4.B	J1.9	RST up
M	4.S	J1.10	RST com
N	5.A	J2.1	C+
P	5.B	J2.2	C-
R	5.S	n.c.	
S	6.A	J3.1	C+
T	6.B	J3.2	C-
U	6.S	n.c.	
V	7.A	J4.1	Lp
W	7.B	J4.2	Lp
X	7.S	n.c.	
Y	8.A		
Z	8.B		
a	8.S		
b	9.A		
c	9.B		
d	9.S		

cable K (vacuum side)

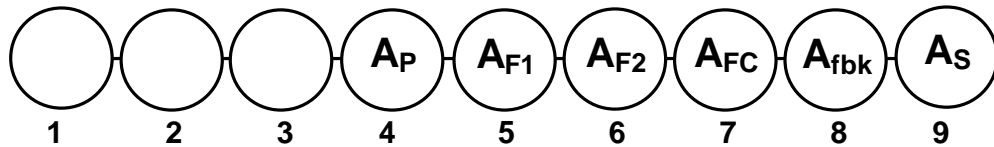
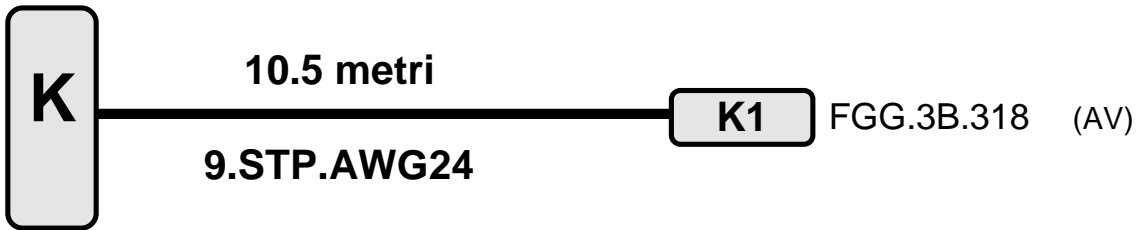

Cutting and Stripping phase
Date:
Operator:
Reel:

Crimping and Labeling phase
Date:
Operator:
Duration (hours):

Quality Control phase
Date:
Operator:

Cleaning and Storage phase
Date:
Operator:

Notes:

MIL-32 contacts	conductors	LEMO contacts	contact description
A	1.A		
B	1.B		
C	1.S		
D	2.A		
E	2.B		
F	2.S		
G	3.A		
H	3.B		
J	3.S		
K	4.A	K1.1	Lp
L	4.B	K1.2	Lp
M	4.S	K1.3	
N	5.A	K1.4	F1 +
P	5.B	K1.5	F1 -
R	5.S	K1.8	
S	6.A	K1.6	F2 +
T	6.B	K1.7	F2 -
U	6.S	K1.18	
V	7.A	K1.9	FC sx
W	7.B	K1.11	FC dx
X	7.S	K1.10	FC com
Y	8.A	K1.12	fbk
Z	8.B	K1.13	fbk
a	8.S	K1.14	
b	9.A	K1.15	Ls
c	9.B	K1.16	Ls
d	9.S	K1.17	

cable L (vacuum side)

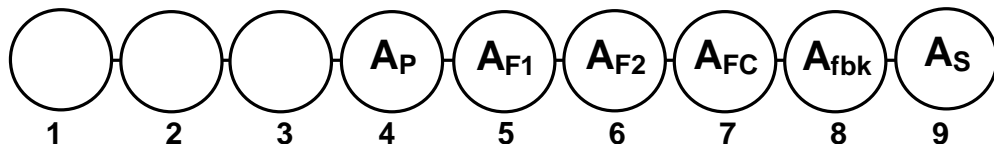
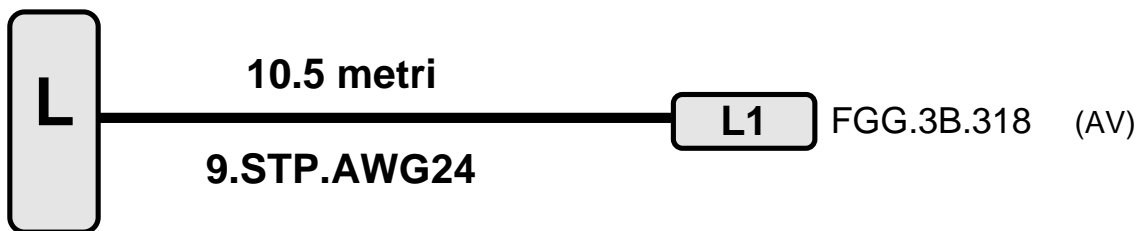

Cutting and Stripping phase
Date:
Operator:
Reel:

Crimping and Labeling phase
Date:
Operator:
Duration (hours):

Quality Control phase
Date:
Operator:

Cleaning and Storage phase
Date:
Operator:

Notes:

MIL-32 contacts	conductors	LEMO contacts	contact description
A	1.A		
B	1.B		
C	1.S		
D	2.A		
E	2.B		
F	2.S		
G	3.A		
H	3.B		
J	3.S		
K	4.A	L1.1	Lp
L	4.B	L1.2	Lp
M	4.S	L1.3	
N	5.A	L1.4	F1 +
P	5.B	L1.5	F1 -
R	5.S	L1.8	
S	6.A	L1.6	F2 +
T	6.B	L1.7	F2 -
U	6.S	L1.18	
V	7.A	L1.9	FC sx
W	7.B	L1.11	FC dx
X	7.S	L1.10	FC com
Y	8.A	L1.12	fbk
Z	8.B	L1.13	fbk
a	8.S	L1.14	
b	9.A	L1.15	Ls
c	9.B	L1.16	Ls
d	9.S	L1.17	

cable M (vacuum side)

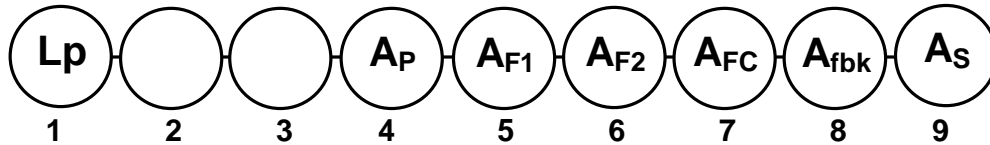
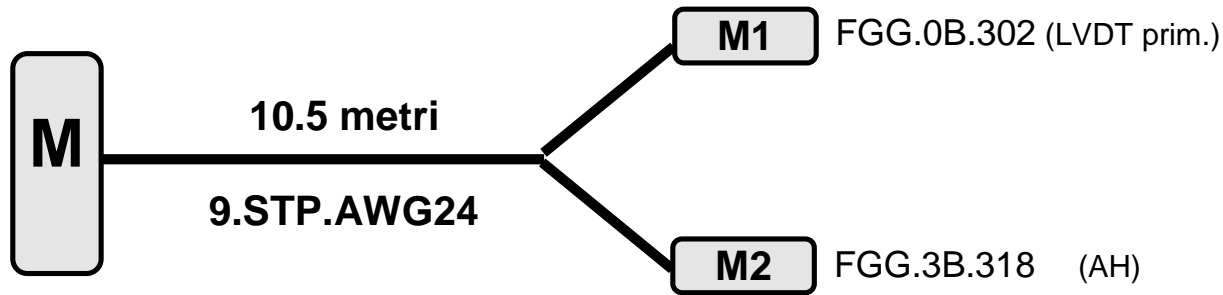

Cutting and Stripping phase
Date:
Operator:
Reel:

Crimping and Labeling phase
Date:
Operator:
Duration (hours):

Quality Control phase
Date:
Operator:

Cleaning and Storage phase
Date:
Operator:

Notes:
Diramare a 60 cm

MIL-32 contacts	conductors	LEMO contacts	contact description
A	1.A	M1.1	Lp
B	1.B	M1.2	Lp
C	1.S	n.c.	
D	2.A		
E	2.B		
F	2.S		
G	3.A		
H	3.B		
J	3.S		
K	4.A	M2.1	Lp
L	4.B	M2.2	Lp
M	4.S	M2.3	
N	5.A	M2.4	F1 +
P	5.B	M2.5	F1 -
R	5.S	M2.8	
S	6.A	M2.6	F2 +
T	6.B	M2.7	F2 -
U	6.S	M2.18	
V	7.A	M2.9	FC sx
W	7.B	M2.11	FC dx
X	7.S	M2.10	FC com
Y	8.A	M2.12	fbk
Z	8.B	M2.13	fbk
a	8.S	M2.14	
b	9.A	M2.15	Ls
c	9.B	M2.16	Ls
d	9.S	M2.17	

cable N (vacuum side)

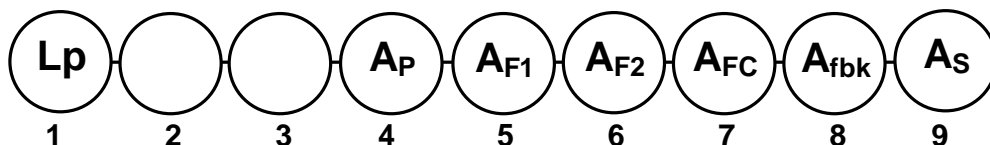
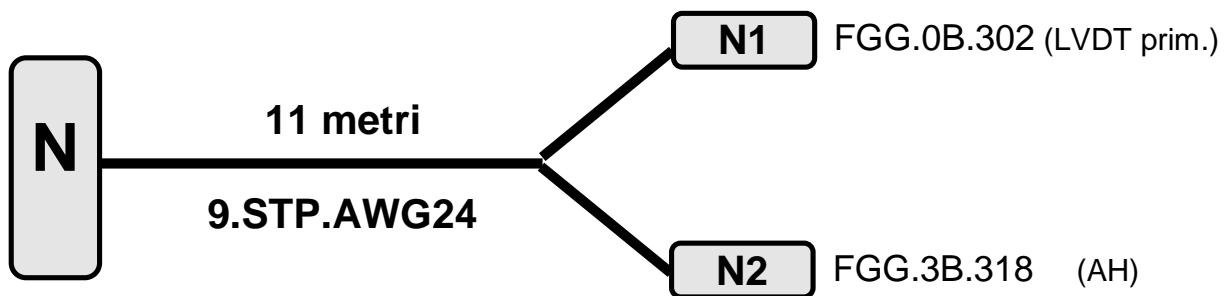

Cutting and Stripping phase
Date:
Operator:
Reel:

Crimping and Labeling phase
Date:
Operator:
Duration (hours):

Quality Control phase
Date:
Operator:

Cleaning and Storage phase
Date:
Operator:

Notes:
Diramare a 60 cm

MIL-32 contacts	conductors	LEMO contacts	contact description
A	1.A	N1.1	Lp
B	1.B	N1.2	Lp
C	1.S	n.c.	
D	2.A		
E	2.B		
F	2.S		
G	3.A		
H	3.B		
J	3.S		
K	4.A	N2.1	Lp
L	4.B	N2.2	Lp
M	4.S	N2.3	
N	5.A	N2.4	F1 +
P	5.B	N2.5	F1 -
R	5.S	N2.8	
S	6.A	N2.6	F2 +
T	6.B	N2.7	F2 -
U	6.S	N2.18	
V	7.A	N2.9	FC sx
W	7.B	N2.11	FC dx
X	7.S	N2.10	FC com
Y	8.A	N2.12	fbk
Z	8.B	N2.13	fbk
a	8.S	N2.14	
b	9.A	N2.15	Ls
c	9.B	N2.16	Ls
d	9.S	N2.17	

cable O (vacuum side)

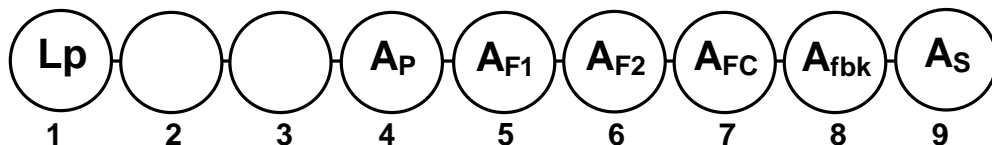
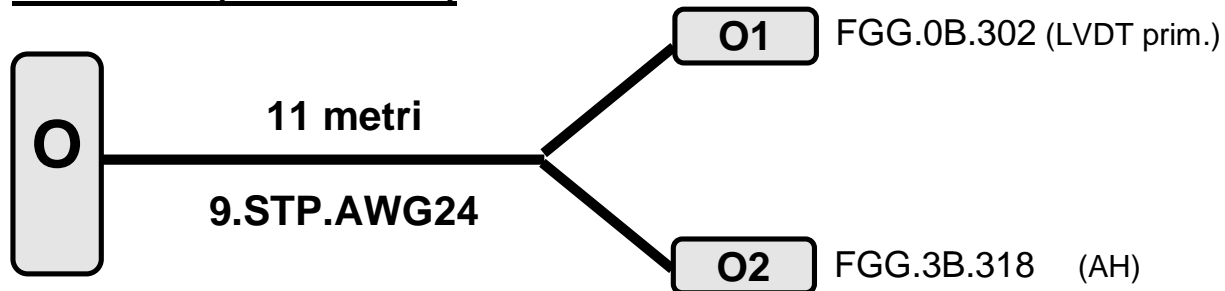

Cutting and Stripping phase
Date:
Operator:
Reel:

Crimping and Labeling phase
Date:
Operator:
Duration (hours):

Quality Control phase
Date:
Operator:

Cleaning and Storage phase
Date:
Operator:

Notes:
Diramare a 60 cm

MIL-32 contacts	conductors	LEMO contacts	contact description
A	1.A	O1.1	Lp
B	1.B	O1.2	Lp
C	1.S	n.c.	
D	2.A		
E	2.B		
F	2.S		
G	3.A		
H	3.B		
J	3.S		
K	4.A	O2.1	Lp
L	4.B	O2.2	Lp
M	4.S	O2.3	
N	5.A	O2.4	F1 +
P	5.B	O2.5	F1 -
R	5.S	O2.8	
S	6.A	O2.6	F2 +
T	6.B	O2.7	F2 -
U	6.S	O2.18	
V	7.A	O2.9	FC sx
W	7.B	O2.11	FC dx
X	7.S	O2.10	FC com
Y	8.A	O2.12	fbk
Z	8.B	O2.13	fbk
a	8.S	O2.14	
b	9.A	O2.15	Ls
c	9.B	O2.16	Ls
d	9.S	O2.17	

cable R (vacuum side)

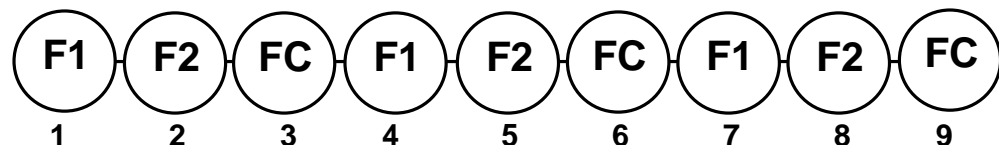
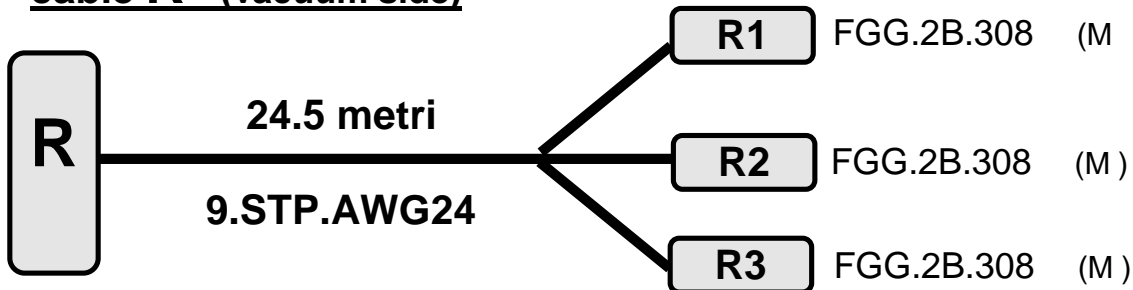

Cutting and Stripping phase
Date:
Operator:
Reel:

Crimping and Labeling phase
Date:
Operator:
Duration (hours):

Quality Control phase
Date:
Operator:

Cleaning and Storage phase
Date:
Operator:

Notes:
Diramare a <u>40 cm</u>

MIL-32 contacts	conductors	LEMO contacts	contact description
A	1.A	R1.1	F1 +
B	1.B	R1.2	F1 -
C	1.S	n.c.	
D	2.A	R1.3	F2 +
E	2.B	R1.4	F2 -
F	2.S	n.c.	
G	3.A	R1.5	FC fw
H	3.B	R1.6	FC bw
J	3.S	R1.7	FC com
K	4.A	R2.1	F1 +
L	4.B	R2.2	F1 -
M	4.S	n.c.	
N	5.A	R2.3	F2 +
P	5.B	R2.4	F2 -
R	5.S	n.c.	
S	6.A	R2.5	FC fw
T	6.B	R2.6	FC bw
U	6.S	R2.7	FC com
V	7.A	R3.1	F1 +
W	7.B	R3.2	F1 -
X	7.S	n.c.	
Y	8.A	R3.3	F2 +
Z	8.B	R3.4	F2 -
a	8.S	n.c.	
b	9.A	R3.5	FC fw
c	9.B	R3.6	FC bw
d	9.S	R3.7	FC com

cable S (vacuum side)

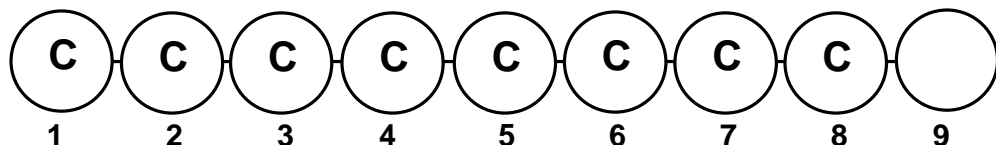

Cutting and Stripping phase
Date:
Operator:
Reel:

Crimping and Labeling phase
Date:
Operator:
Duration (hours):

Quality Control phase
Date:
Operator:

Cleaning and Storage phase
Date:
Operator:

Notes:
Diramare a <u>150 cm</u> ;
Ponticelli su MIL-32.

MIL-32 contacts	conductors	LEMO contacts	contact description
A ←	1.A	S1.1	C +
B ←	1.B	S1.2	C -
C ←	1.S	n.c.	
D ←	2.A	S1.1	C +
E ←	2.B	S1.2	C -
F ←	2.S	n.c.	
G ←	3.A	S2.1	C +
H ←	3.B	S2.2	C -
J ←	3.S	n.c.	
K ←	4.A	S2.1	C +
L ←	4.B	S2.2	C -
M ←	4.S	n.c.	
N ←	5.A	S3.1	C +
P ←	5.B	S3.2	C -
R ←	5.S	n.c.	
S ←	6.A	S3.1	C +
T ←	6.B	S3.2	C -
U ←	6.S	n.c.	
V ←	7.A	S4.1	C +
W ←	7.B	S4.2	C -
X ←	7.S	n.c.	
Y ←	8.A	S4.1	C +
Z ←	8.B	S4.2	C -
a	8.S	n.c.	
b	9.A		
c	9.B		
d	9.S		

cable T (vacuum side)

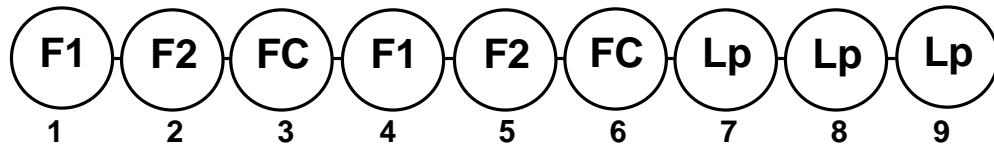
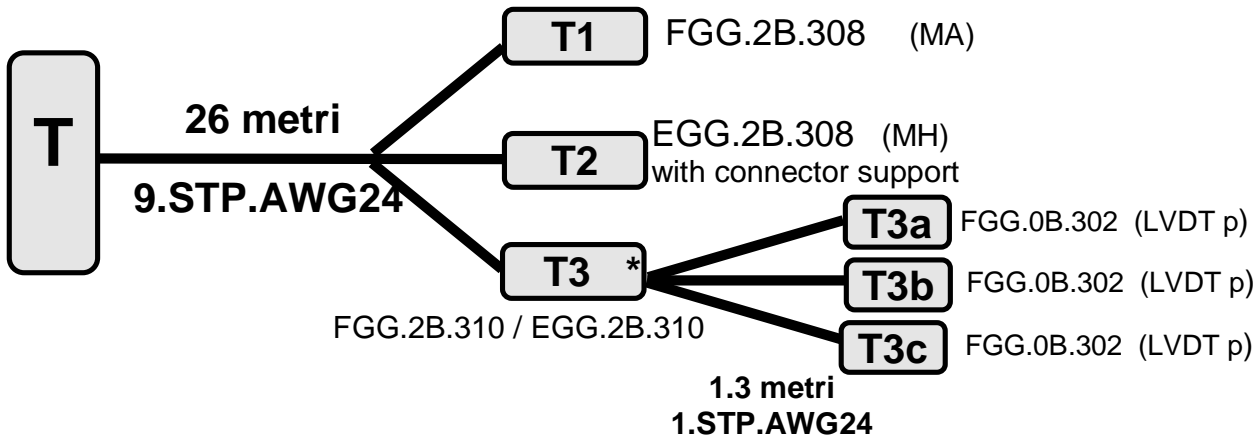

Cutting and Stripping phase
Date: 7 feb 00
Operator: Ceccanti
Reel: H

Crimping and Labeling phase
Date: 7 feb 00
Operator: Ceccanti
Duration (hours): 3

Quality Control phase
Date: 7 feb 00
Operator: Ceccanti

Cleaning and Storage phase
Date:
Operator:

Notes:
 Diramare a 30 cm
 Upgraded on 5 may 03 by Nenci with T3 and additional cables for LVDTs

MIL-32 contacts	conductors	LEMO contacts	contact description
A	1.A	T1.1	F1 +
B	1.B	T1.2	F1 -
C	1.S	n.c.	
D	2.A	T1.3	F2 +
E	2.B	T1.4	F2 -
F	2.S	n.c.	
G	3.A	T1.5	FC fw
H	3.B	T1.6	FC bw
J	3.S	T1.7	FC com
K	4.A	T2.1	F1 +
L	4.B	T2.2	F1 -
M	4.S	n.c.	
N	5.A	T2.3	F2 +
P	5.B	T2.4	F2 -
R	5.S	n.c.	
S	6.A	T2.5	FC fw
T	6.B	T2.6	FC bw
U	6.S	T2.7	FC com
V	7.A	T3.1	T3a.1 Lp *
W	7.B	T3.2	T3a.2 Lp *
X	7.S	T3.3	
Y	8.A	T3.4	T3b.1 Lp *
Z	8.B	T3.5	T3b.2 Lp *
a	8.S	T3.6	
b	9.A	T3.7	T3c.1 Lp *
c	9.B	T3.8	T3c.2 Lp *
d	9.S	T3.9	

cable U (vacuum side)

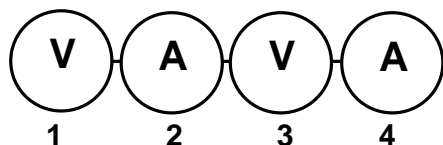
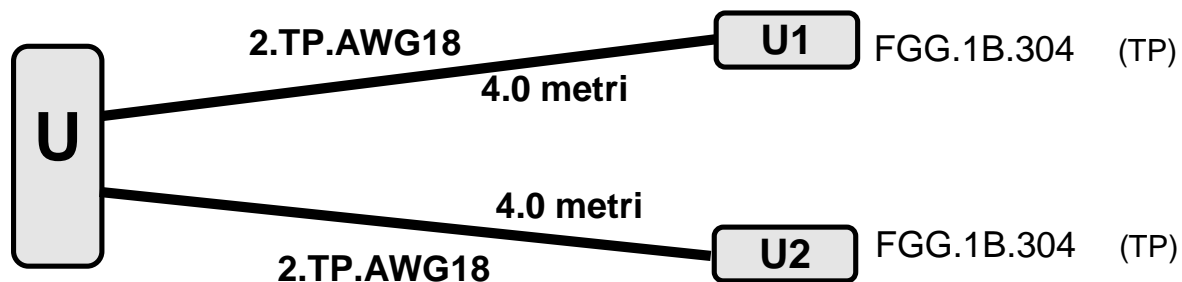

Cutting and Stripping phase
Date:
Operator: <i>Dattilo, Gherardini</i>
Reel:

Crimping and Labeling phase
Date: <i>18 feb 2010</i>
Operator: <i>Gherardini</i>
Duration (hours):

Quality Control phase
Date: <i>19 feb 2010</i>
Operator: <i>Dattilo, Gherardini</i>

Cleaning and Storage phase
Date: <i>19 feb 2010</i>
Operator: <i>Gherardini</i>

Notes:
 Cavo in Pyre-ML
 V_H = Voltmetric High, A_H = Amperometric High, etc.

MIL-32 contacts	conductors	LEMO contacts	contact description
A	1.A	U1.1	V _H
B	1.B	U1.2	V _L
C	2.A	U1.3	A _L
D	2.B	U1.4	A _H
E	3.A	U2.1	V _H
F	3.B	U2.2	V _L
G	4.A	U2.3	A _L
H	4.B	U2.4	A _H
I			
J			
K			
L			
M			
N			
P			
Q			
R			
S			
T			
U			
V			
W			
X			
Y			
Z			
A			
b			
c			
d			

cable V (vacuum side)

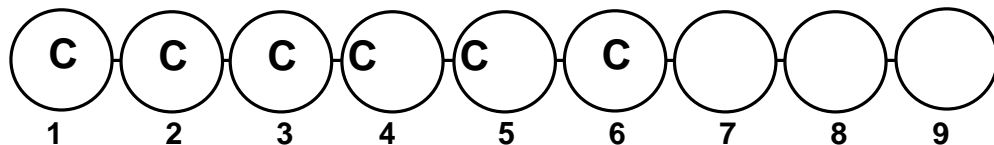
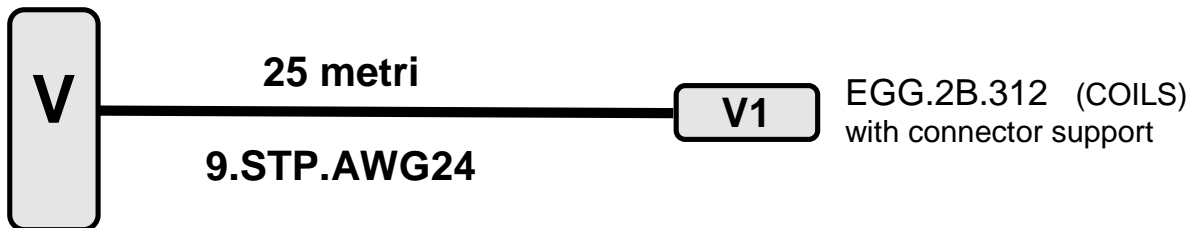

Cutting and Stripping phase	
Date:	
Operator:	
Reel:	

Crimping and Labeling phase	
Date:	
Operator:	
Duration (hours):	

Quality Control phase	
Date:	
Operator:	

Cleaning and Storage phase	
Date:	
Operator:	

Notes:

MIL-32 contacts	conductors	LEMO contacts	contact description
A	1.A	V1.1	C +
B	1.B	V1.2	C -
C	1.S	n.c.	
D	2.A	V1.3	C +
E	2.B	V1.4	C -
F	2.S	n.c.	
G	3.A	V1.5	C +
H	3.B	V1.6	C -
J	3.S	n.c.	
K	4.A	V1.7	C +
L	4.B	V1.8	C -
M	4.S	n.c.	
N	5.A	V1.9	C +
P	5.B	V1.10	C -
R	5.S	n.c.	
S	6.A	V1.11	C +
T	6.B	V1.12	C -
U	6.S	n.c.	
V	7.A		
W	7.B		
X	7.S		
Y	8.A		
Z	8.B		
a	8.S		
b	9.A		
c	9.B		
d	9.S		

cable W (vacuum side)

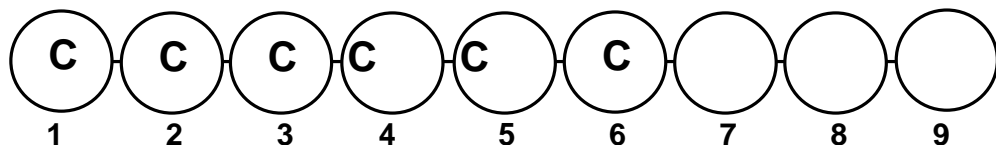
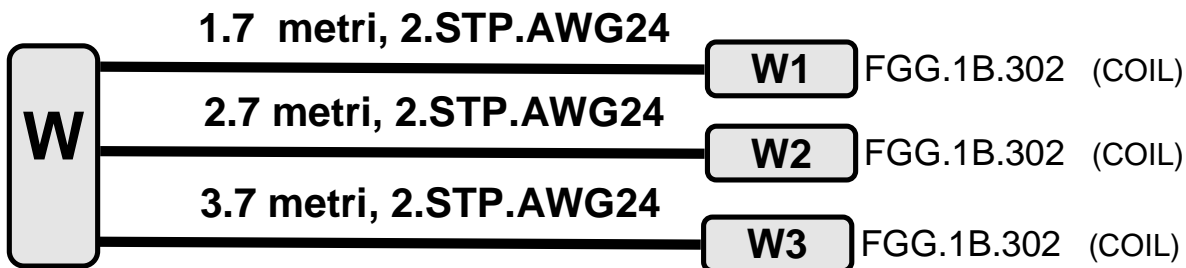

Cutting and Stripping phase
Date: <i>may . 03</i>
Operator: <i>Nenci</i>
Reel:

Crimping and Labeling phase
Date: <i>may 03</i>
Operator: <i>Nenci</i>
Duration (hours):

Quality Control phase
Date: <i>may . 03</i>
Operator: <i>Nenci</i>

Cleaning and Storage phase
Date:
Operator:

Notes:
Ponticelli su MIL-32.

MIL-32 contacts	conductors	LEMO contacts	contact description
A ←	1.A	W1.1	C +
B ←	1.B	W1.2	C -
C ←	1.S	n.c.	
D ←	2.A	W1.1	C +
E ←	2.B	W1.2	C -
F ←	2.S	n.c.	
G ←	3.A	W2.1	C +
H ←	3.B	W2.2	C -
J ←	3.S	n.c.	
K ←	4.A	W2.1	C +
L ←	4.B	W2.2	C -
M ←	4.S	n.c.	
N ←	5.A	W3.1	C +
P ←	5.B	W3.2	C -
R ←	5.S	n.c.	
S ←	6.A	W3.1	C +
T ←	6.B	W3.2	C -
U ←	6.S	n.c.	
V			
W			
X			
Y			
Z			
a			
b			
c			
d			

cable X (vacuum side)

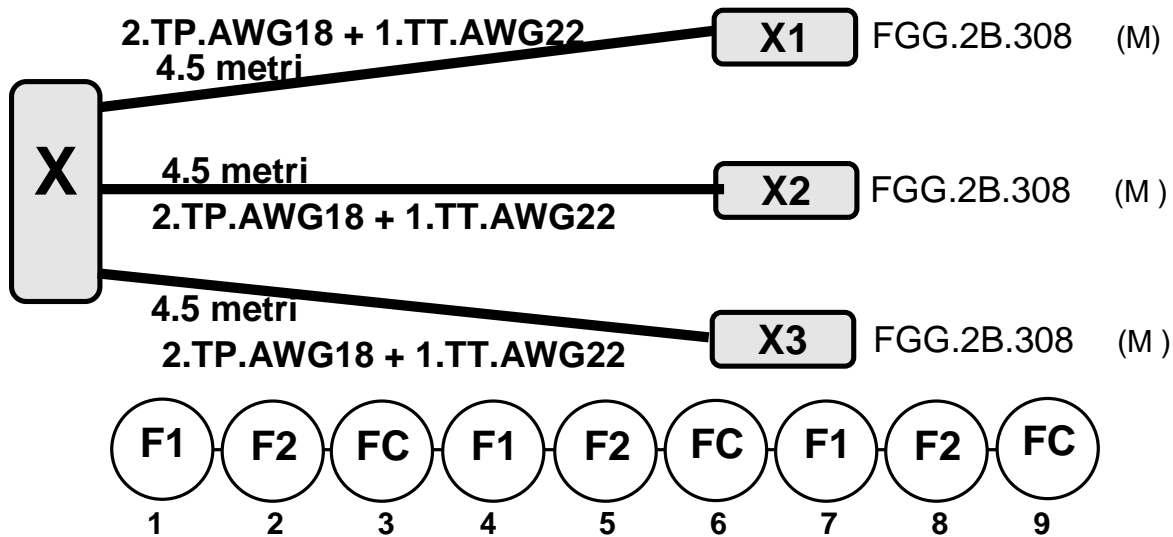

Cutting and Stripping phase
Date:
Operator: <i>Dattilo, Gherardini</i>
Reel:

Crimping and Labeling phase
Date:
Operator: <i>Dattilo, Gherardini</i>
Duration (hours):

Quality Control phase
Date:
Operator: <i>Dattilo, Gherardini</i>

Cleaning and Storage phase
Date:
Operator: <i>Dattilo, Gherardini</i>

Notes:
I conduttori dei cavi TP e TT vanno identificati utilizzando il tester

MIL-32 contacts	conductors	LEMO contacts	contact description
A	1.A	X1.1	F1 +
B	1.B	X1.2	F1 -
C	2.A	X1.3	F2 +
D	2.B	X1.4	F2 -
E	3.A	X1.5	FC fw
F	3.B	X1.6	FC bw
G	3.C	X1.7	FC com
H	4.A	X2.1	F1 +
J	4.B	X2.2	F1 -
K	5.A	X2.3	F2 +
L	5.B	X2.4	F2 -
M	6.A	X2.5	FC fw
N	6.B	X2.6	FC bw
P	6.C	X2.7	FC com
R	7.A	X3.1	F1 +
S	7.B	X3.2	F1 -
T	8.A	X3.3	F2 +
U	8.B	X3.4	F2 -
V	9.A	X3.5	FC fw
W	9.B	X3.6	FC bw
X	9.C	X3.7	FC com
Y			
Z			
a			
b			
c			
d			