

# **DETECTION Tower:**

## **Cables SCHEMES**

### Change History

<b>Version</b>	<b>Date</b>	<b>Changes</b>	<b>Author</b>
<b>v1</b>	May-Jun 1999	initial suspension cabling	Dattilo, Ceccanti
<b>v2</b>	Oct 2008	Changes for putting the photodiodes under vacuum. Note: never deployed. It was left only a larger disk on F#7 bottom for clamping more cables	Berni, Dattilo, Gherardini
<b>v3r0</b>	Oct-Nov 2014	Cabling adaptation for AdV:	Berni, Dattilo, Gherardini

### **Contents**

IDENTIFICAZIONE COMPONENTI.....	2
LEGENDA .....	3
LEMO PINOUT OF THE MAIN DEVICES .....	3
<b>CABLE A (VACUUM SIDE) .....</b>	<b>4</b>
<b>CABLE BA (VACUUM SIDE).....</b>	<b>5</b>
<b>CABLE BB (VACUUM SIDE).....</b>	<b>6</b>
<b>CABLE BC (VACUUM SIDE).....</b>	<b>7</b>
<b>CABLE BD (VACUUM SIDE).....</b>	<b>8</b>
<b>CABLE BE (VACUUM SIDE).....</b>	<b>9</b>
<b>CABLE BF (VACUUM SIDE) .....</b>	<b>10</b>
<b>CABLE BF (VACUUM SIDE).....</b>	<b>11</b>
<b>CABLE BG (VACUUM SIDE) .....</b>	<b>12</b>
<b>CABLE BH (VACUUM SIDE) .....</b>	<b>13</b>
<b>CABLE BI (VACUUM SIDE).....</b>	<b>14</b>
<b>CABLE E (VACUUM SIDE).....</b>	<b>15</b>
<b>CABLE F (VACUUM SIDE).....</b>	<b>16</b>
<b>CABLE G (VACUUM SIDE) .....</b>	<b>17</b>
<b>CABLE I (VACUUM SIDE).....</b>	<b>18</b>
<b>CABLE J (VACUUM SIDE) .....</b>	<b>19</b>
<b>CABLE K (VACUUM SIDE) .....</b>	<b>20</b>
<b>CABLE L (VACUUM SIDE).....</b>	<b>21</b>
<b>CABLE M (VACUUM SIDE) .....</b>	<b>22</b>
<b>CABLE N (VACUUM SIDE) .....</b>	<b>23</b>
<b>CABLE O (VACUUM SIDE).....</b>	<b>24</b>
<b>CABLE P (VACUUM SIDE).....</b>	<b>25</b>
<b>CABLE R (VACUUM SIDE) .....</b>	<b>26</b>
<b>CABLE S (VACUUM SIDE).....</b>	<b>27</b>
<b>CABLE T (VACUUM SIDE).....</b>	<b>28</b>

## Informazioni generali

Ciascun spezzone di cavo va terminato ad una estremità da un connettore circolare 32 poli (tipo presa), all'altra estremità con uno o più connettori Lemo multipolari (generalmente tipo spina). I cavi sono del tipo:

I cavi sono di questo tipo (se non diversamente specificato):

- cavo piatto a 16 conduttori AWG 26 a coppie intrecciate e schermate singolarmente (cavo STP).
- cavo piatto a 16-20 conduttori AWG 24 a coppie intrecciate e schermate singolarmente (cavo STP).
- cavo piatto a 16 conduttori AWG 20 a coppie intrecciate e schermate singolarmente (cavo STP).

## Identificazione componenti

- Ciascun cavo è identificato da una lettera dell'alfabeto.
- Il tipo di cavo utilizzato e' indicato in prossimità' del disegno: la sigla comprende il numero di coppie di conduttori, il tipo di schermatura (STP o PP), la sezione (AWGxx). Es.: la sigla **10.STP.AWG24** specifica un tipo di cavo avente 10 coppie STP, di sezione AWG24
- Ciascun conduttore di un cavo STP è identificato dalla lettera identificativa del cavo, da un numero cardinale relativo alla coppia (**1** per una delle 2 coppie laterali<sup>1</sup>, a seguire fino al max 10 per le altre coppie), da una lettera (**N** (o **A**) per il conduttore con strisce nere (o gialle), **B** l'altro conduttore della coppia, **S** la calza) (es. la calza nella terza coppia appartenente al cavo **E**, è identificata da **E.3S** ).
- Ciascun conduttore di un cavo PP è identificato dalla lettera identificativa del cavo, da un numero cardinale relativo al conduttore (**1** per una dei due conduttori laterali<sup>1</sup>, a seguire fino a **14** per gli altri conduttori) (es. il quinto conduttore appartenente al cavo **G**, è identificato da **G.5** ).
- Ciascun connettore MIL32 e' identificato da una lettera, uguale a quella del cavo di appartenenza.
- Ciascun connettore Lemo è identificato da due caratteri: il primo è la lettera del cavo sul quale è saldato il connettore, il secondo è un numero cardinale, che va da 1 al n. max di connettori Lemo sullo stesso cavo (es. per il cavo **B** terminato da due Lemo, essi sono identificati da **B1** e **B2**)
- I contatti di ciascun connettore sono identificati dal nome del connettore, seguito dal numero del contatto indicato sull'isolante del connettore (es il contatto<sup>2</sup> n. 4 che si trova sul connettore Lemo **B3** e' identificato da **B3.4**).

---

<sup>1</sup> Il conduttore/coppia laterale va definita dall'operatore in sede di preparazione cavo, in quanto una tale marcatura non e' già' presente sui cavi – e' presente solo sui cavi più' recenti, gli AWG26, dove la prima coppia ha un conduttore con strisce rosse, anziché' gialle.

<sup>2</sup> Nel caso di conduttori Lemo, il contatto n. 1 e' quello col semicerchio bianco, i successivi sono quelli lungo la linea bianca che parte dal contatto n. 1.

## Legenda

<b>F1 +</b>	motore, fase 1, positivo
<b>F1 -</b>	motore, fase 1, negativo
<b>F2 +</b>	motore, fase 2, positivo
<b>F2 -</b>	motore, fase 2, negativo
<b>FC cw</b>	motore, fine corsa che si incontra quando l'albero gira <u>in senso orario</u> per un osservatore coincidente con il motore
<b>FC ccw</b>	motore, fine corsa che si incontra quando l'albero gira <u>in senso antiorario</u> per un osservatore coincidente con il motore
<b>FC com</b>	motore, fine corsa, comune
<b>RST up</b>	motore, reostato, terminale superiore
<b>RST down</b>	motore, reostato, terminale inferiore
<b>RST com</b>	motore, reostato, comune o cursore
<b>TP sx +</b>	thermal probe, sinistro, positivo
<b>TP sx -</b>	thermal probe, sinistro, negativo
<b>TP dx +</b>	thermal probe, destro, positivo
<b>TP dx -</b>	thermal probe, destro, negativo
<b>Ls</b>	LVDT, secondario
<b>Lp</b>	LVDT, primario
<b>C +</b>	coil attuatore, positivo
<b>C -</b>	coil attuatore, negativo
<b>fbk</b>	accelerometro, feedback
<b>PZ</b>	piezoelectric

## LEMO pinout of the main devices

ACCELEROMETER	
LEMO contacts	Contact descript.
1	Lp
2	Lp
3	
4	F1 +
5	F1 -
6	F2 +
7	F2 -
8	
9	FC cw
11	FC ccw
10	FC com
12	fbk
13	fbk
14	
15	Ls
16	Ls
17	
18	

LVDT	
LEMO contacts	Contact descript.
1	Lp +
2	Lp -
3	Ls +
4	Ls -

COIL	
LEMO contacts	Contact descript.
1	C +
2	C -

MOTOR		
LEMO contact	Contact descript.	UTG 12p contacts
1	F1 +	A
2	F1 -	B
3	F1 shield	C
4	F2 +	D
5	F2 -	E
6	F2 shield	F
7	FC cw	G
8	FC ccw	H
	FC com	J
	n.c.	

**cable A** (vacuum side)

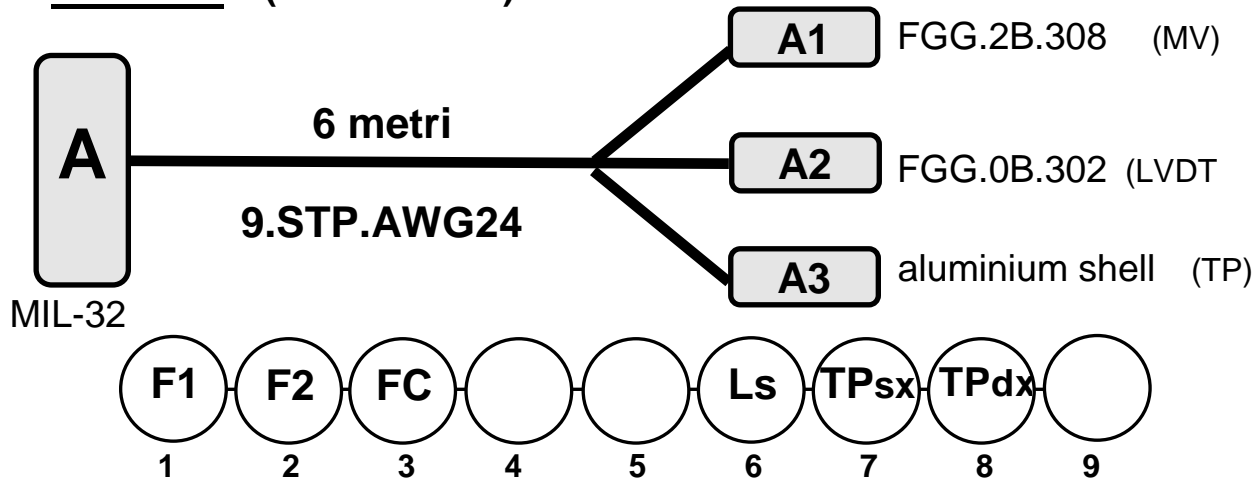

Cutting and Stripping phase
Date:
Operator:
Reel: <i>old cable S of NE tower</i>

Crimping and Labeling phase
Date:
Operator:
Duration (hours):

Quality Control phase
Date:
Operator:

Cleaning and Storage phase
Date:
Operator:

Notes:
Rifatto ex-novo a ottobre 2014. Per lo schema del vecchio cavo A vedere la versione v2.
<b>Diramare a 60 cm</b>
- obtained by the former S cable of NE tower cabling.

MIL-32 contacts	conductors	LEMO contacts	contact description
A	1.A	A1.1	F1 +
B	1.B	A1.2	F1 -
C	1.S	n.c.	
D	2.A	A1.3	F2 +
E	2.B	A1.4	F2 -
F	2.S	n.c.	
G	3.A	A1.5	FC cw
H	3.B	A1.6	FC ccw
J	3.S	A1.7	FC com
K	4.A		
L	4.B		
M	4.S		
N	5.A		
P	5.B		
R	5.S		
S	6.A	A2.1	Ls
T	6.B	A2.2	Ls
U	6.S	n.c.	
V	7.A	A3	TP sx +
W	7.B	A3	TP sx -
X	7.S	n.c.	
Y	8.A	A3	TP dx +
Z	8.B	A3	TP dx -
a	8.S	n.c.	
b	9.A		
c	9.B		
d	9.S		

**cable BA (vacuum side)**

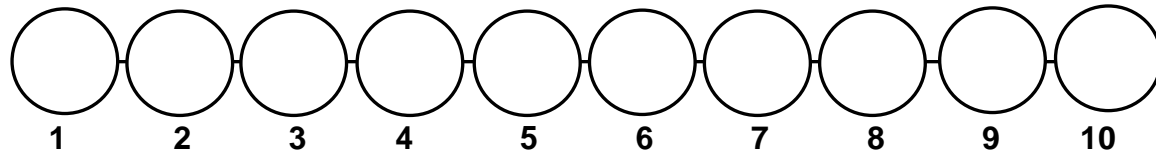
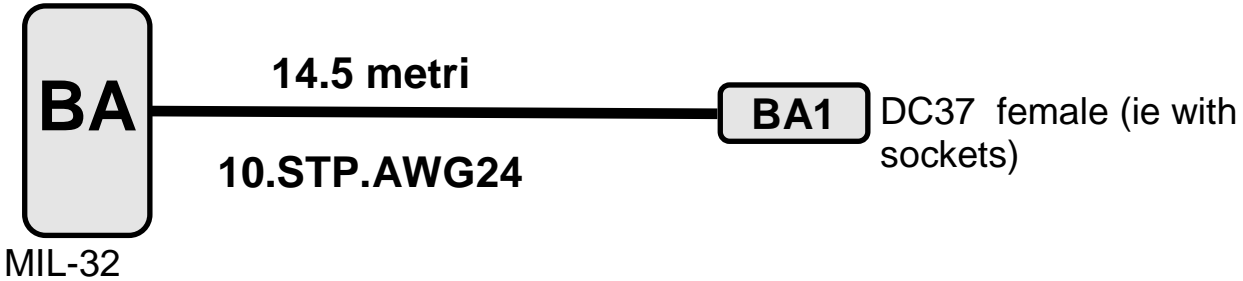

Cutting and Stripping phase
Date:
Operator:
Reel:

Crimping and Labeling phase
Date:
Operator:
Duration (hours):

Quality Control phase
Date:
Operator:

Cleaning and Storage phase
Date:
Operator:

Notes:
Cable connecting the devices on SDB1

MIL-32 contacts	conductors	DC-37 contacts	contact description
A	1.A	1	
B	1.B	2	
C	1.S	20	
D	2.A	21	
E	2.B	22	
F	2.S	3	
G	3.A	4	
H	3.B	5	
J	3.S	23	
K	4.A	24	
L	4.B	25	
M	4.S	6	
N	5.A	7	
P	5.B	8	
R	5.S	26	
S	6.A	27	
T	6.B	28	
U	6.S	9	
V	7.A	10	
W	7.B	11	
X	7.S	29	
Y	8.A	30	
Z	8.B	31	
a	8.S	12	
b	9.A	13	
c	9.B	14	
d	9.S	32	
e	10.A	33	
f	10.B	34	
g	10.S	15	

**cable BB (vacuum side)**

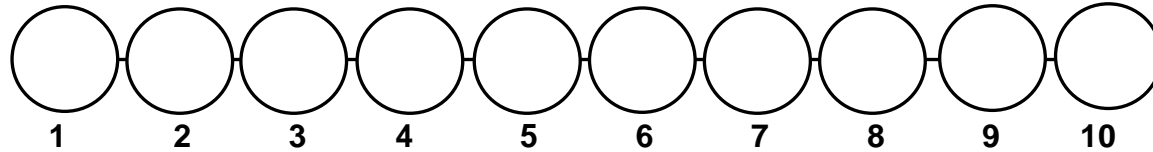
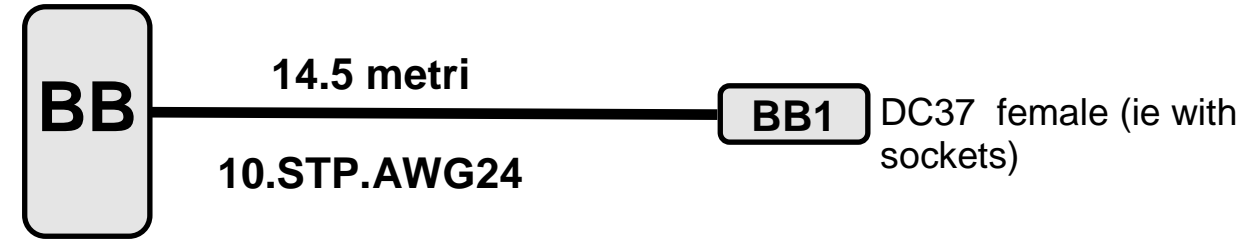

Cutting and Stripping phase
Date:
Operator:
Reel:

Crimping and Labeling phase
Date:
Operator:
Duration (hours):

Quality Control phase
Date:
Operator:

Cleaning and Storage phase
Date:
Operator:

Notes:
Cable connecting the devices on SDB1

MIL-32 contacts	conductors	DC-37 contacts	contact description
A	1.A	1	
B	1.B	2	
C	1.S	20	
D	2.A	21	
E	2.B	22	
F	2.S	3	
G	3.A	4	
H	3.B	5	
J	3.S	23	
K	4.A	24	
L	4.B	25	
M	4.S	6	
N	5.A	7	
P	5.B	8	
R	5.S	26	
S	6.A	27	
T	6.B	28	
U	6.S	9	
V	7.A	10	
W	7.B	11	
X	7.S	29	
Y	8.A	30	
Z	8.B	31	
a	8.S	12	
b	9.A	13	
c	9.B	14	
d	9.S	32	
e	10.A	33	
f	10.B	34	
g	10.S	15	

**cable BC (vacuum side)**

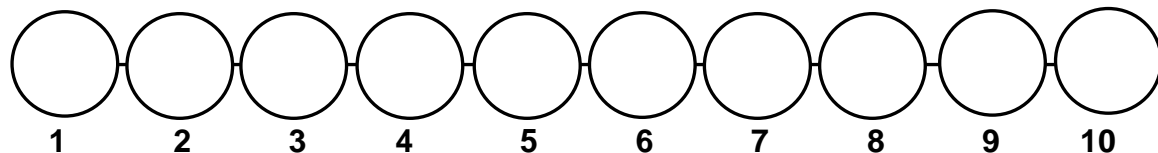
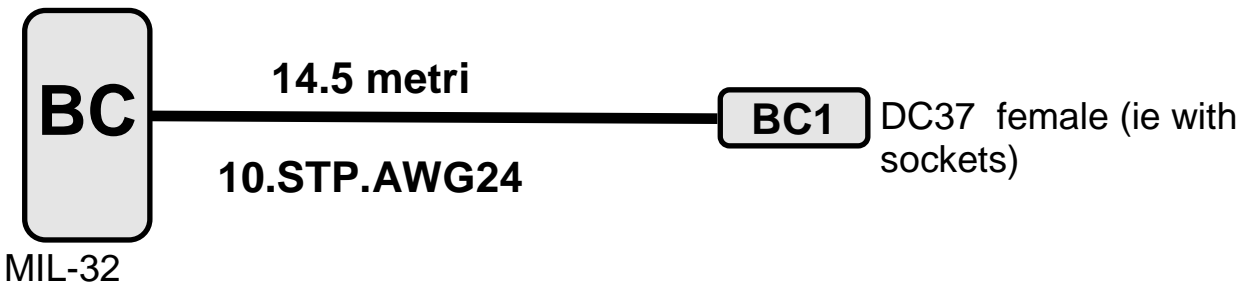

Cutting and Stripping phase
Date:
Operator:
Reel:

Crimping and Labeling phase
Date:
Operator:
Duration (hours):

Quality Control phase
Date:
Operator:

Cleaning and Storage phase
Date:
Operator:

Notes:
Cable connecting the devices on SDB1

MIL-32 contacts	conductors	DC-37 contacts	contact description
A	1.A	1	
B	1.B	2	
C	1.S	20	
D	2.A	21	
E	2.B	22	
F	2.S	3	
G	3.A	4	
H	3.B	5	
J	3.S	23	
K	4.A	24	
L	4.B	25	
M	4.S	6	
N	5.A	7	
P	5.B	8	
R	5.S	26	
S	6.A	27	
T	6.B	28	
U	6.S	9	
V	7.A	10	
W	7.B	11	
X	7.S	29	
Y	8.A	30	
Z	8.B	31	
a	8.S	12	
b	9.A	13	
c	9.B	14	
d	9.S	32	
e	10.A	33	
f	10.B	34	
g	10.S	15	

**cable BD (vacuum side)**

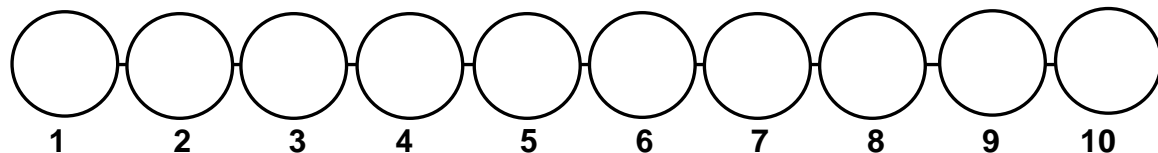
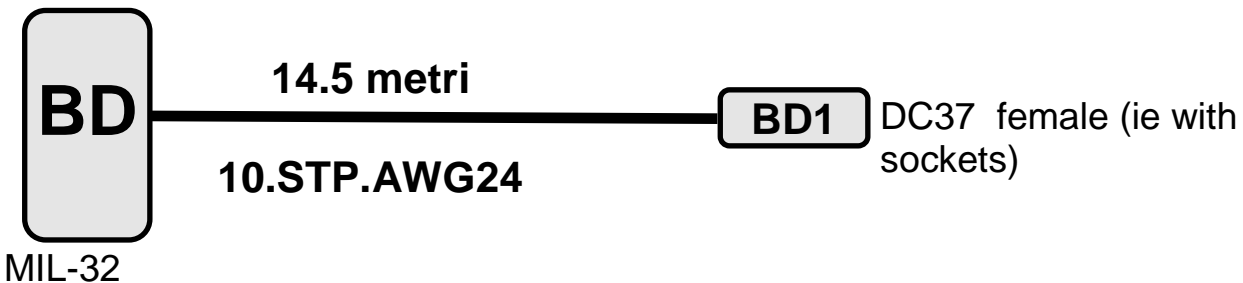

Cutting and Stripping phase
Date:
Operator:
Reel:

Crimping and Labeling phase
Date:
Operator:
Duration (hours):

Quality Control phase
Date:
Operator:

Cleaning and Storage phase
Date:
Operator:

Notes:
Cable connecting the device on SDB1

MIL-32 contacts	conductors	DC-37 contacts	contact description
A	1.A	1	
B	1.B	2	
C	1.S	20	
D	2.A	21	
E	2.B	22	
F	2.S	3	
G	3.A	4	
H	3.B	5	
J	3.S	23	
K	4.A	24	
L	4.B	25	
M	4.S	6	
N	5.A	7	
P	5.B	8	
R	5.S	26	
S	6.A	27	
T	6.B	28	
U	6.S	9	
V	7.A	10	
W	7.B	11	
X	7.S	29	
Y	8.A	30	
Z	8.B	31	
a	8.S	12	
b	9.A	13	
c	9.B	14	
d	9.S	32	
e	10.A	33	
f	10.B	34	
g	10.S	15	



**cable BE (vacuum side)**

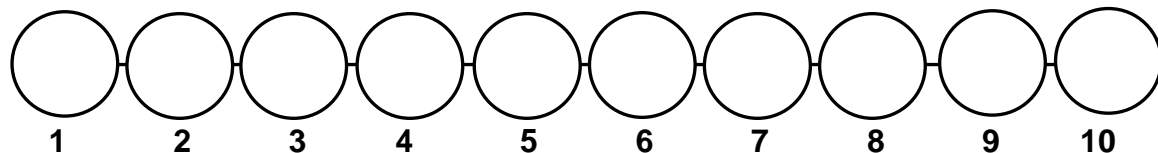
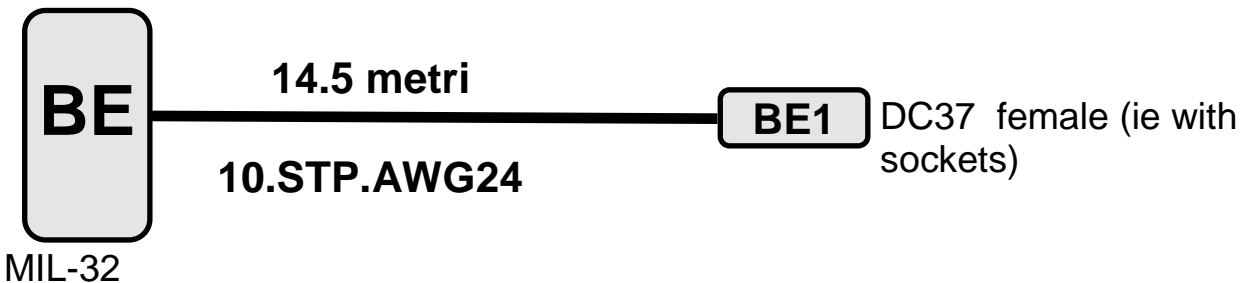

Cutting and Stripping phase
Date:
Operator:
Reel:

Crimping and Labeling phase
Date:
Operator:
Duration (hours):

Quality Control phase
Date:
Operator:

Cleaning and Storage phase
Date:
Operator:

Notes:
Cable connecting the device on SDB1

MIL-32 contacts	conductors	DC-37 contacts	contact description
A	1.A	1	
B	1.B	2	
C	1.S	20	
D	2.A	21	
E	2.B	22	
F	2.S	3	
G	3.A	4	
H	3.B	5	
J	3.S	23	
K	4.A	24	
L	4.B	25	
M	4.S	6	
N	5.A	7	
P	5.B	8	
R	5.S	26	
S	6.A	27	
T	6.B	28	
U	6.S	9	
V	7.A	10	
W	7.B	11	
X	7.S	29	
Y	8.A	30	
Z	8.B	31	
a	8.S	12	
b	9.A	13	
c	9.B	14	
d	9.S	32	
e	10.A	33	
f	10.B	34	
g	10.S	15	

**cable BF (vacuum side)**

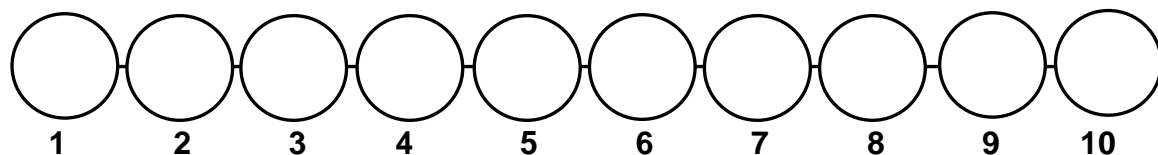
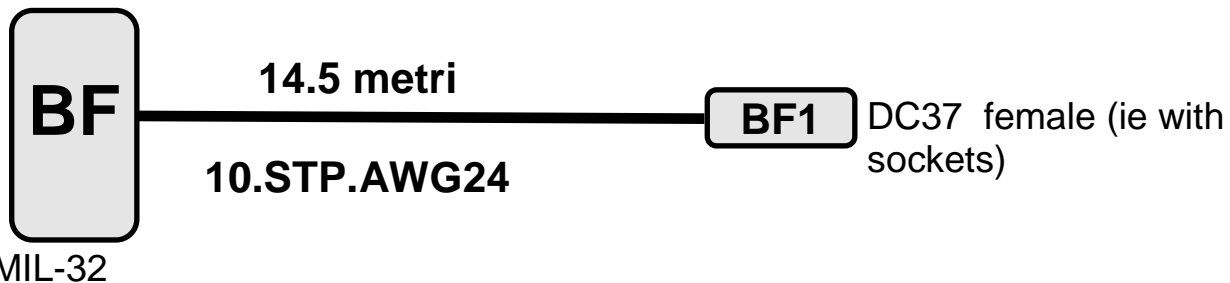

Cutting and Stripping phase
Date:
Operator:
Reel:

Crimping and Labeling phase
Date:
Operator:
Duration (hours):

Quality Control phase
Date:
Operator:

Cleaning and Storage phase
Date:
Operator:

Notes:
Cable connecting the devices on SDB1

MIL-32 contacts	conductors	DC-37 contacts	contact description
A	1.A	1	
B	1.B	2	
C	1.S	20	
D	2.A	21	
E	2.B	22	
F	2.S	3	
G	3.A	4	
H	3.B	5	
J	3.S	23	
K	4.A	24	
L	4.B	25	
M	4.S	6	
N	5.A	7	
P	5.B	8	
R	5.S	26	
S	6.A	27	
T	6.B	28	
U	6.S	9	
V	7.A	10	
W	7.B	11	
X	7.S	29	
Y	8.A	30	
Z	8.B	31	
a	8.S	12	
b	9.A	13	
c	9.B	14	
d	9.S	32	
e	10.A	33	
f	10.B	34	
g	10.S	15	

**cable BF (vacuum side)**

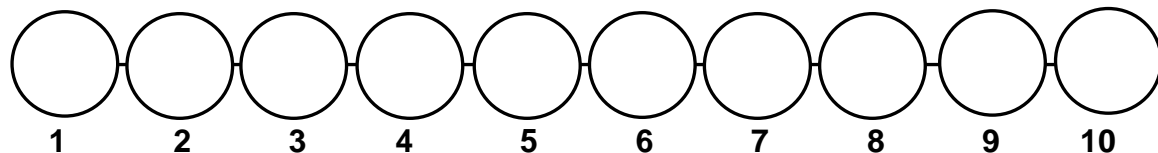
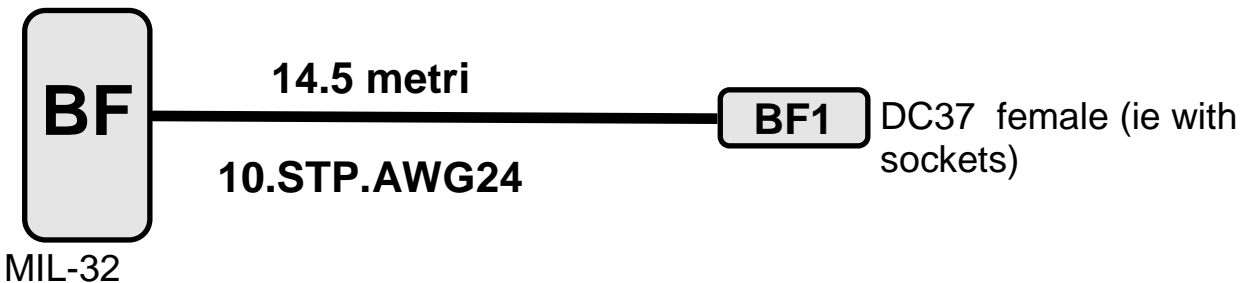

Cutting and Stripping phase
Date:
Operator:
Reel:

Crimping and Labeling phase
Date:
Operator:
Duration (hours):

Quality Control phase
Date:
Operator:

Cleaning and Storage phase
Date:
Operator:

Notes:
Cable connecting the devices on SDB1

MIL-32 contacts	conductors	DC-37 contacts	contact description
A	1.A	1	
B	1.B	2	
C	1.S	20	
D	2.A	21	
E	2.B	22	
F	2.S	3	
G	3.A	4	
H	3.B	5	
J	3.S	23	
K	4.A	24	
L	4.B	25	
M	4.S	6	
N	5.A	7	
P	5.B	8	
R	5.S	26	
S	6.A	27	
T	6.B	28	
U	6.S	9	
V	7.A	10	
W	7.B	11	
X	7.S	29	
Y	8.A	30	
Z	8.B	31	
a	8.S	12	
b	9.A	13	
c	9.B	14	
d	9.S	32	
e	10.A	33	
f	10.B	34	
g	10.S	15	

**cable BG (vacuum side)**

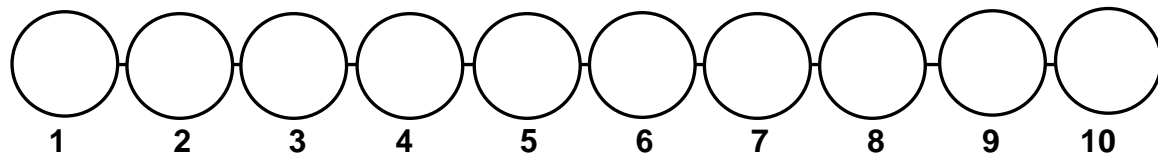
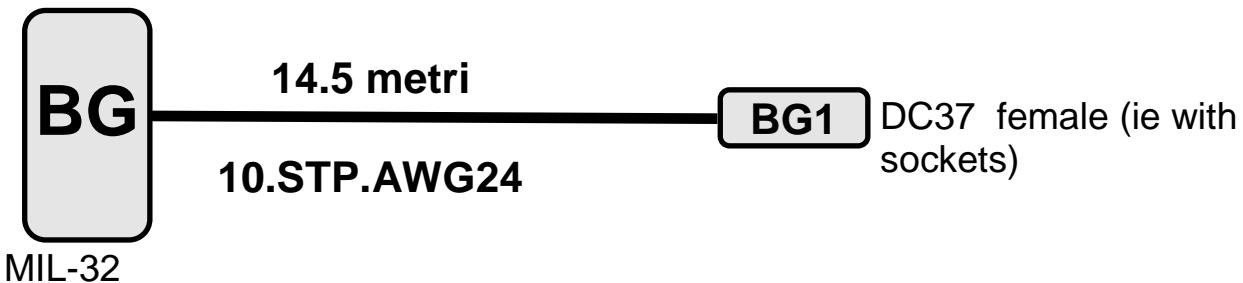

Cutting and Stripping phase
Date:
Operator:
Reel:

Crimping and Labeling phase
Date:
Operator:
Duration (hours):

Quality Control phase
Date:
Operator:

Cleaning and Storage phase
Date:
Operator:

Notes:
Cable connecting the device on SDB1

MIL-32 contacts	conductors	DC-37 contacts	contact description
A	1.A	1	
B	1.B	2	
C	1.S	20	
D	2.A	21	
E	2.B	22	
F	2.S	3	
G	3.A	4	
H	3.B	5	
J	3.S	23	
K	4.A	24	
L	4.B	25	
M	4.S	6	
N	5.A	7	
P	5.B	8	
R	5.S	26	
S	6.A	27	
T	6.B	28	
U	6.S	9	
V	7.A	10	
W	7.B	11	
X	7.S	29	
Y	8.A	30	
Z	8.B	31	
a	8.S	12	
b	9.A	13	
c	9.B	14	
d	9.S	32	
e	10.A	33	
f	10.B	34	
g	10.S	15	

**cable BH (vacuum side)**

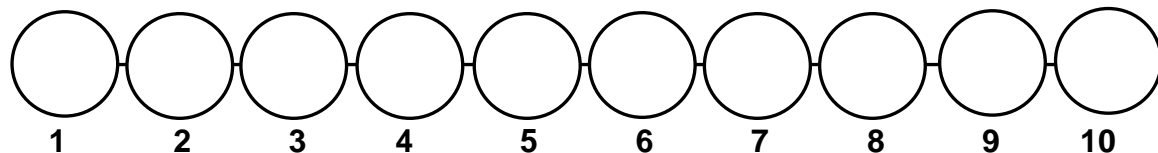
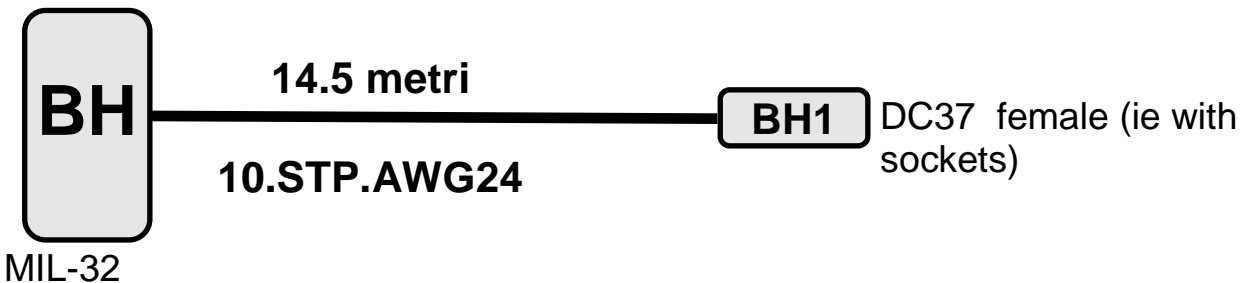

Cutting and Stripping phase
Date:
Operator:
Reel:

Crimping and Labeling phase
Date:
Operator:
Duration (hours):

Quality Control phase
Date:
Operator:

Cleaning and Storage phase
Date:
Operator:

Notes:
Cable connecting the devices on SDB1

MIL-32 contacts	conductors	DC-37 contacts	contact description
A	1.A	1	
B	1.B	2	
C	1.S	20	
D	2.A	21	
E	2.B	22	
F	2.S	3	
G	3.A	4	
H	3.B	5	
J	3.S	23	
K	4.A	24	
L	4.B	25	
M	4.S	6	
N	5.A	7	
P	5.B	8	
R	5.S	26	
S	6.A	27	
T	6.B	28	
U	6.S	9	
V	7.A	10	
W	7.B	11	
X	7.S	29	
Y	8.A	30	
Z	8.B	31	
a	8.S	12	
b	9.A	13	
c	9.B	14	
d	9.S	32	
e	10.A	33	
f	10.B	34	
g	10.S	15	

**cable BI (vacuum side)**

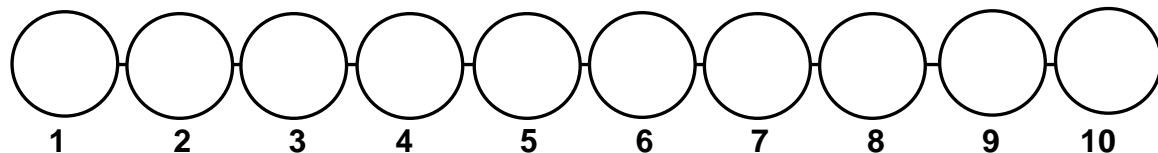
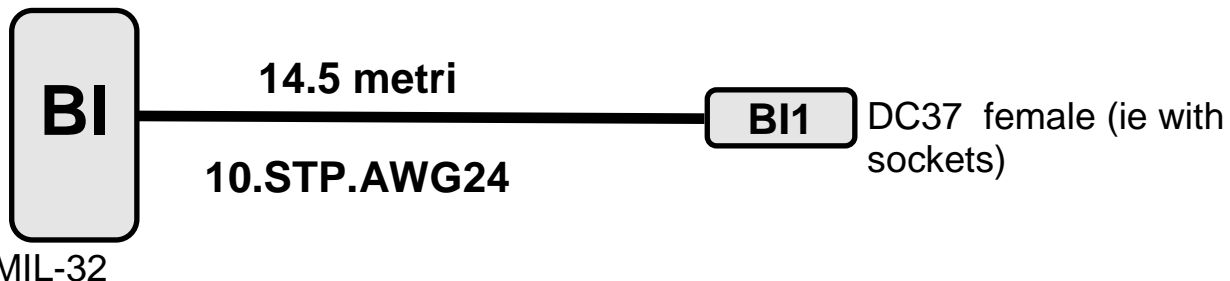

Cutting and Stripping phase
Date:
Operator:
Reel:

Crimping and Labeling phase
Date:
Operator:
Duration (hours):

Quality Control phase
Date:
Operator:

Cleaning and Storage phase
Date:
Operator:

Notes:
Cable connecting the devices on SDB1

MIL-32 contacts	conductors	DC-37 contacts	contact description
A	1.A	1	
B	1.B	2	
C	1.S	20	
D	2.A	21	
E	2.B	22	
F	2.S	3	
G	3.A	4	
H	3.B	5	
J	3.S	23	
K	4.A	24	
L	4.B	25	
M	4.S	6	
N	5.A	7	
P	5.B	8	
R	5.S	26	
S	6.A	27	
T	6.B	28	
U	6.S	9	
V	7.A	10	
W	7.B	11	
X	7.S	29	
Y	8.A	30	
Z	8.B	31	
a	8.S	12	
b	9.A	13	
c	9.B	14	
d	9.S	32	
e	10.A	33	
f	10.B	34	
g	10.S	15	

**cable E** (vacuum side)

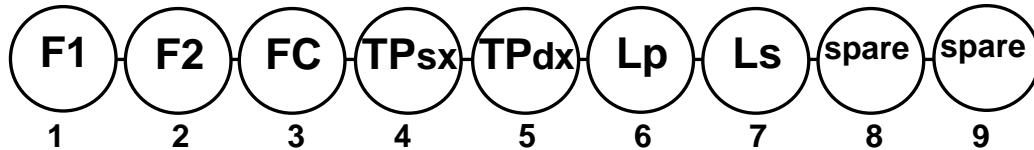
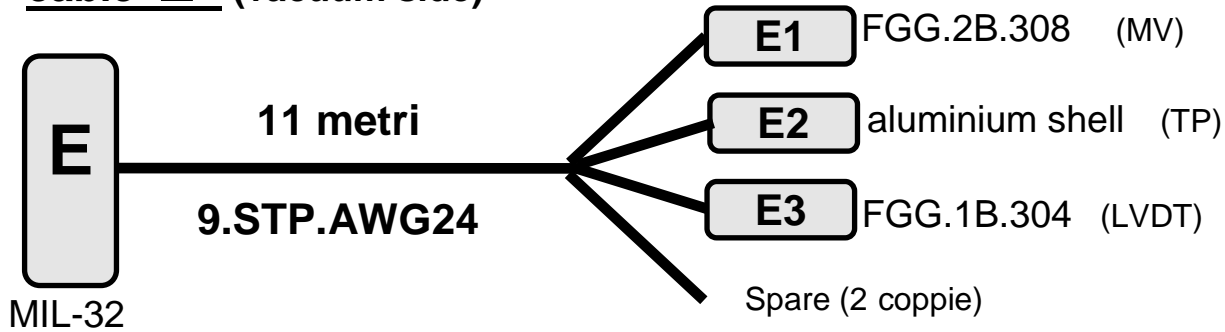

Cutting and Stripping phase
Date:
Operator: <i>F. Berni</i>
Reel: <i>old cable R of NE tower</i>

Crimping and Labeling phase
Date:
Operator: <i>F. Berni</i>
Duration (hours):

Quality Control phase
Date:
Operator:

Cleaning and Storage phase
Date:
Operator:

Notes:
<b>Diramare a 60 cm</b>
- obtained by the former R cable of NE tower cabling

MIL-32 contacts	conductors	LEMO contacts	contact description
A	1.A	E1.1	F1 +
B	1.B	E1.2	F1 -
C	1.S	n.c.	
D	2.A	E1.3	F2 +
E	2.B	E1.4	F2 -
F	2.S	n.c.	
G	3.A	E1.5	FC cw
H	3.B	E1.6	FC ccw
J	3.S	E1.7	FC com
K	4.A	E2	TP sx +
L	4.B	E2	TP sx -
M	4.S	n.c.	
N	5.A	E2	TP dx +
P	5.B	E2	TP dx -
R	5.S	n.c.	
S	6.A	E3.1	Lp
T	6.B	E3.2	Lp
U	6.S	n.c.	
V	7.A	E3.3	Ls
W	7.B	E3.4	Ls
X	7.S	n.c.	
Y	9.A	n.c	
Z	9.B	n.c.	
a	9.S	n.c.	
b	8.A	n.c	
c	8.B	n.c.	
d	8.S	n.c.	

**cable F** (vacuum side)

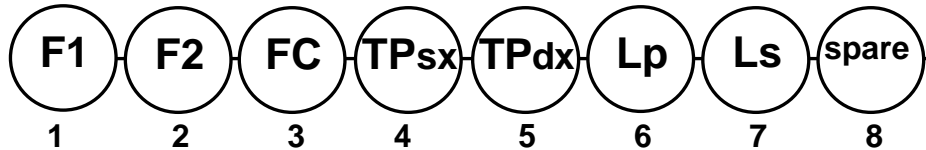
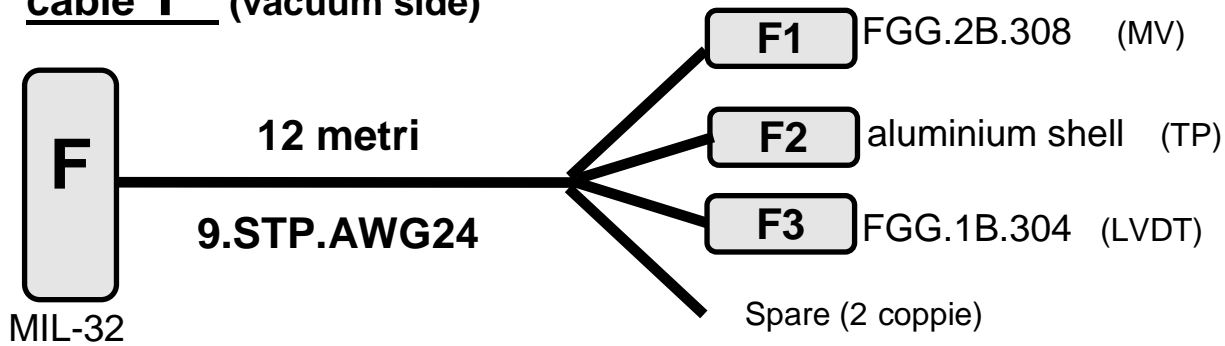

Cutting and Stripping phase	Crimping and Labeling phase
Date:	Date:
Operator: <i>F. Berni</i>	Operator: <i>F. Berni</i>
Reel: <i>old cable R of NE tower</i>	Duration (hours):

Quality Control phase	Cleaning and Storage phase
Date:	Date:
Operator:	Operator:

**Notes:**

Rifatto ex-novo ad ottobre 2014. Per lo schema del vecchio cavo F vedere la versione v2.

**Diramare a 60 cm**

- obtained by the former R cable of NE tower cabling
- use the pre-existing TP aluminium shell of former cable F

MIL-32 contacts	conductors	LEMO contacts	contact description
A	1.A	F1.1	F1 +
B	1.B	F1.2	F1 -
C	1.S	n.c.	
D	2.A	F1.3	F2 +
E	2.B	F1.4	F2 -
F	2.S	n.c.	
G	3.A	F1.5	FC cw
H	3.B	F1.6	FC ccw
J	3.S	F1.7	FC com
K	4.A	F2	TP sx +
L	4.B	F2	TP sx -
M	4.S	n.c.	
N	5.A	F2	TP dx +
P	5.B	F2	TP dx -
R	5.S	n.c.	
S	6.A	F3.1	Lp
T	6.B	F3.2	Lp
U	6.S	n.c.	
V	7.A	F3.3	Ls
W	7.B	F3.4	Ls
X	7.S	n.c.	
Y	8.A	n.c.	
Z	8.B	n.c.	
a	8.S	n.c.	
b	9.A		
c	9.B		
d	9.S		



**Cable G** (vacuum side)

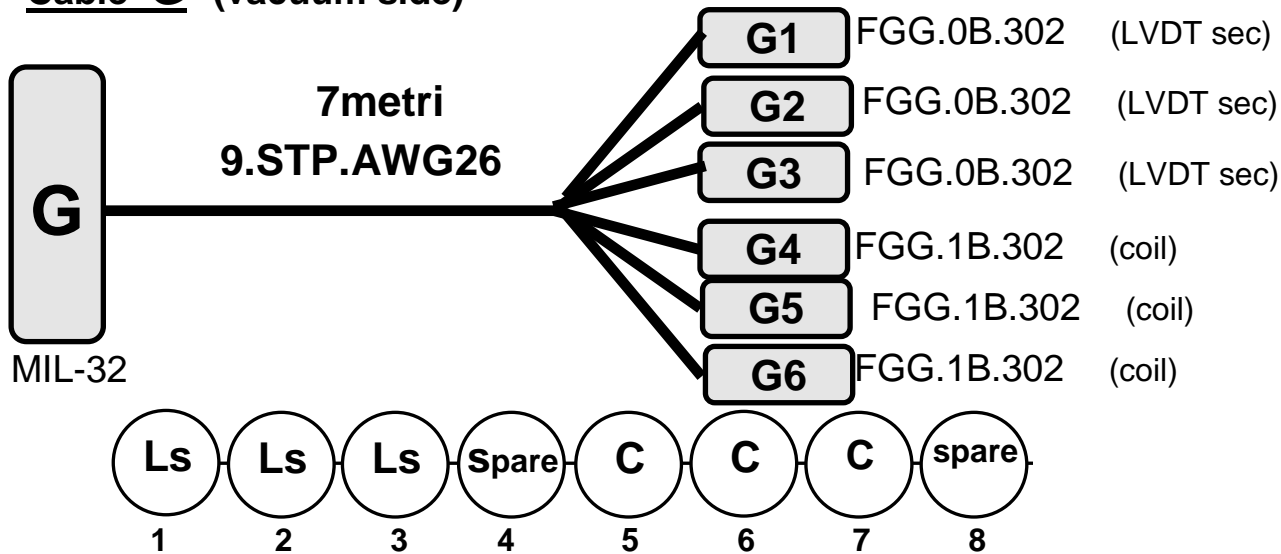

Fase di Taglio
Date:
Operator: <i>F. Berni</i>
Reel: <i>old cable F of BS tower</i>

Fase di Crimpaggio e Labeling
Date:
Operator: <i>F. Berni</i>
Duration (hours):

Quality Control phase
Date:
Operator:

Cleaning and Storage phase
Date:
Operator:

**Note:**  
 Diramare a 1.5 metri.. Tagliare Ramo G1 e G4 piu' corti di 1 metro, Ramo G2 e G5 piu' corti di 0.5 metri (rispetto a 7 metri).  
 Rifatto ex-novo ad ottobre 2014. Per lo schema del vecchio cavo G vedere la versione v2.  
 - obtained by the former F cable of BS tower cabling.

MIL-32 contacts	conductors	LEMO contacts	Contact description
A	1.A	G1.1	Ls
B	1.B	G1.2	Ls
C	1.S	n.c.	
D	2.A	G2.1	Ls
E	2.B	G2.2	Ls
F	2.S	n.c.	
G	3.A	G3.1	Ls
H	3.B	G3.2	Ls
J	3.S	n.c.	
K	4.A	n.c.	
L	4.B	n.c.	
M	4.S	n.c.	
N	5.A	G4.1	C +
P	5.B	G4.2	C -
R	5.S	n.c.	
S	6.A	G5.1	C +
T	6.B	G5.2	C -
U	6.S	n.c.	
V	7.A	G6.1	C +
W	7.B	G6.2	C -
X	7.S	n.c.	
Y	8.A	n.c.	
Z	8.B	n.c.	
a	8.S	n.c.	
b	9.A	n.c.	
c	9.B	n.c.	
d	9.S	n.c.	

**cable I** (vacuum side)

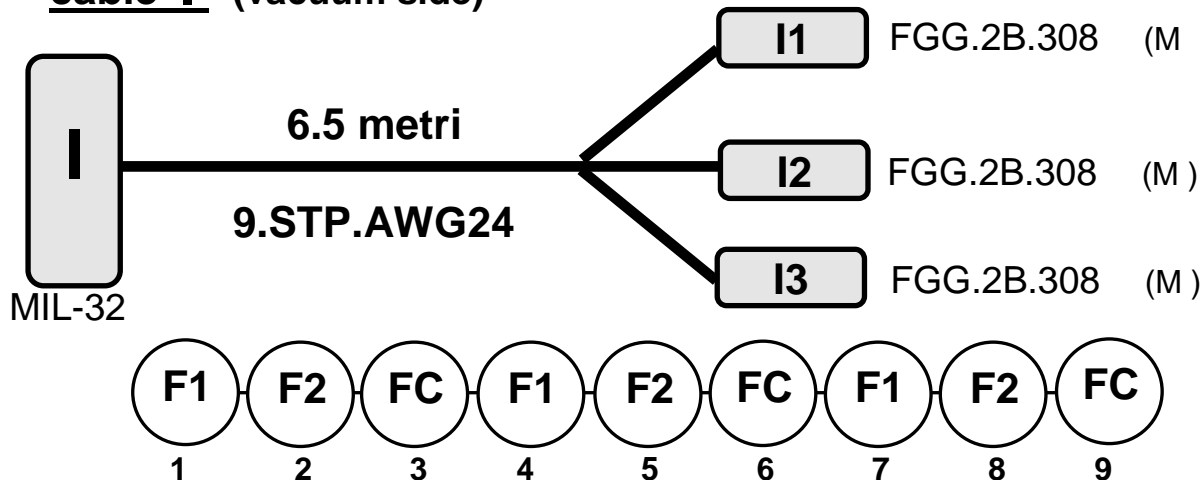

**Cutting and Stripping phase**

Date:  
Operator: *F. Berni*  
Reel: *old cable F of BS tower*

**Crimping and Labeling phase**

Date:  
Operator: *F. Berni*  
Duration (hours):

**Quality Control phase**

Date:  
Operator:

**Cleaning and Storage phase**

Date:  
Operator:

**Notes:**

**Diramare di 2,5 metri; Scorciare I2 di 1.5 metri.**

Rifatto ex-novo ad ottobre 2014. Per lo schema del vecchio cavo I vedere la versione v2.

- obtained by the former F cable of BS tower cabling.

MIL-32 contacts	conductors	LEMO contacts	contact description
A	1.A	I1.1	F1 +
B	1.B	I1.2	F1 -
C	1.S	n.c.	
D	2.A	I1.3	F2 +
E	2.B	I1.4	F2 -
F	2.S	n.c.	
G	3.A	I1.5	FC cw
H	3.B	I1.6	FC ccw
J	3.S	I1.7	FC com
K	4.A	I2.1	F1 +
L	4.B	I2.2	F1 -
N	4.S	n.c.	
N	5.A	I2.3	F2 +
P	5.B	I2.4	F2 -
R	5.S	n.c.	
S	6.A	I2.5	FC cw
T	6.B	I2.6	FC ccw
U	6.S	I2.7	FC com
V	7.A	I3.1	F1 +
W	7.B	I3.2	F1 -
X	7.S	n.c.	
Y	8.A	I3.3	F2 +
Z	8.B	I3.4	F2 -
a	8.S	n.c.	
b	9.A	I3.5	FC cw
c	9.B	I3.6	FC ccw
d	9.S	I3.7	FC com

**cable J** (vacuum side)

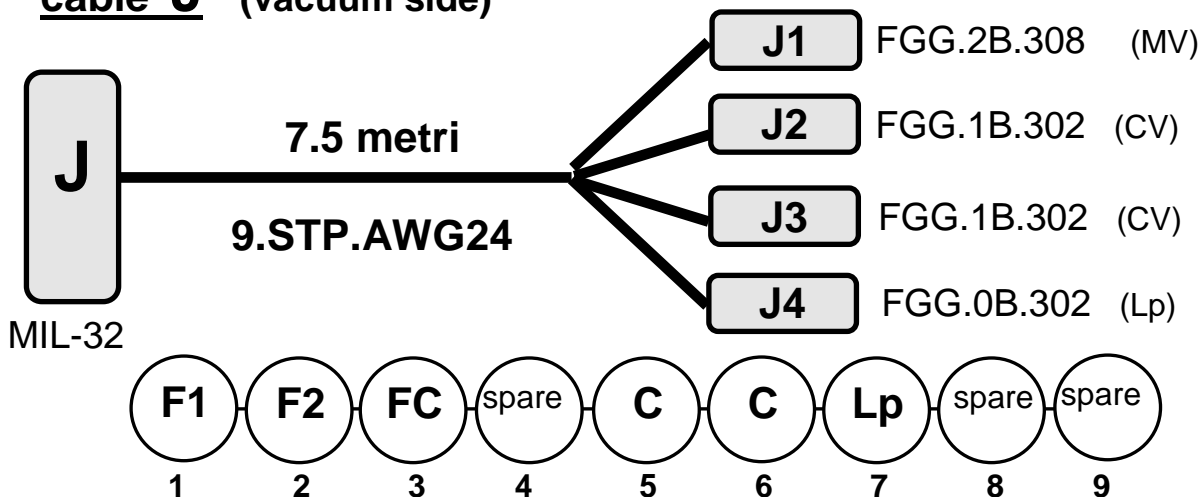

Cutting and Stripping phase
Date:
Operator: <i>F. Berni</i>
Reel: <i>old cable F of BS tower</i>

Crimping and Labeling phase
Date:
Operator: <i>F. Berni</i>
Duration (hours):

Quality Control phase
Date:
Operator:

Cleaning and Storage phase
Date:
Operator:

Notes:
<p>-Diramare a 120 cm tra J2 e J3; Diramare J3 e J4 di 25 cm;                      Scorciare J1 di 120 cm; Scorciare J2 di 20 cm.</p> <p>Rifatto ex-novo ad ottobre 2014. Per lo schema del vecchio cavo J vedere la versione v2.</p> <p>- obtained by the former F cable of BS tower cabling.</p>

MIL-32 contacts	conductors	LEMO contacts	contact description
A	1.A	J1.1	F1 +
B	1.B	J1.2	F1 -
C	1.S	n.c.	
D	2.A	J1.3	F2 +
E	2.B	J1.4	F2 -
F	2.S	n.c.	
G	3.A	J1.5	FC cw
H	3.B	J1.6	FC ccw
J	3.S	J1.7	FC com
K	4.A		
L	4.B		
M	4.S		
N	5.A	J2.1	C+
P	5.B	J2.2	C-
R	5.S	n.c.	
S	6.A	J3.1	C+
T	6.B	J3.2	C-
U	6.S	n.c.	
V	7.A	J4.1	Lp
W	7.B	J4.2	Lp
X	7.S	n.c.	
Y	8.A		
Z	8.B		
a	8.S		
b	9.A		
c	9.B		
d	9.S		

**Cable K (vacuum side)**

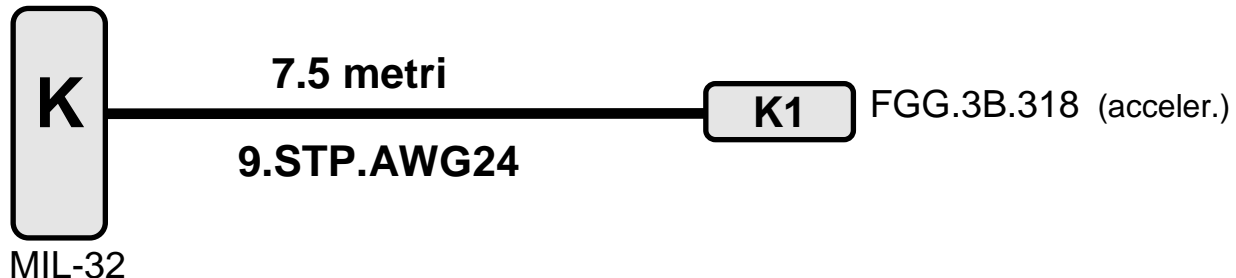

Fase di Taglio e Spelatura
Data:
Operatore/i:
Reel: <i>old cable T of BS tower</i>

Fase di Crimpaggio e Labeling
Data:
Operatore/i:
Tempo impiegato (ore):

Fase di Controllo Qualita'
Data:
Operatore/i:

Fase di Lavaggio e Storage
Data:
Operatore/i:

**Note:**  
 Rifatto ex-novo ad ottobre 2014. Per lo schema del vecchio cavo K vedere la versione v2.  
 - obtained by the former T cable of BS tower cabling.

MIL-32 contacts	conductors	LEMO contacts	Contact description
A	1.A		
B	1.B		
C	1.S		
D	2.A		
E	2.B		
F	2.S		
G	3.A	K1.1	Lp
H	3.B	K1.2	Lp
J	3.S	K1.3	
K	4.A	K1.4	F1 +
L	4.B	K1.5	F1 -
M	4.S	K1.8	
N	5.A	K1.6	F2 +
P	5.B	K1.7	F2 -
R	5.S	K1.18	
S	6.A	K1.9	FC cw
T	6.B	K1.11	FC ccw
U	6.S	K1.10	FC com
V	7.A	K1.12	fbk
W	7.B	K1.13	fbk
X	7.S	K1.14	
Y	8.A	K1.15	Ls
Z	8.B	K1.16	Ls
a	8.S	K1.17	
b	9.A		
c	9.B		
d	9.S		

## Cable L (vacuum side)

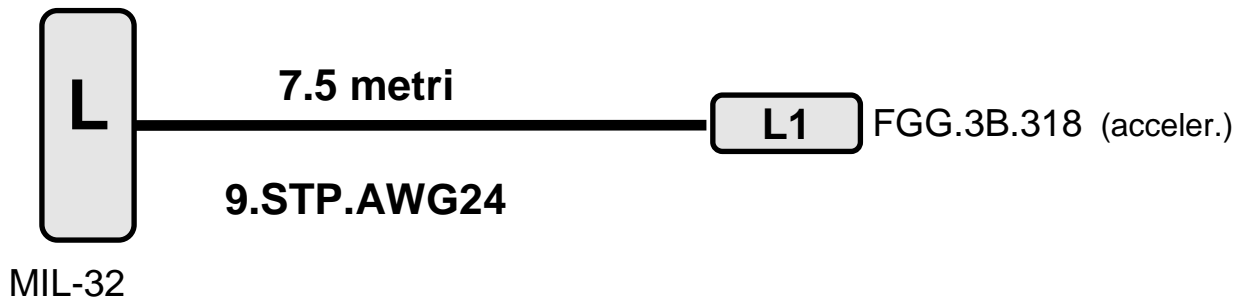

Fase di Taglio e Spelatura
Data:
Operatore/i:
Reel: <i>old cable T of BS tower</i>

Fase di Crimpaggio e Labeling
Data:
Operatore/i:
Tempo impiegato (ore):

Fase di Controllo Qualita'
Data:
Operatore/i:

Fase di Lavaggio e Storage
Data:
Operatore/i:

### Note:

Rifatto ex-novo ad ottobre 2014. Per lo schema del vecchio cavo K vedere la versione v2.

- obtained by the former T cable of BS tower cabling.

MIL-32 contacts	conductors	LEMO contacts	Contact description
A	1.A		
B	1.B		
C	1.S		
D	2.A		
E	2.B		
F	2.S		
G	3.A	L1.1	Lp
H	3.B	L1.2	Lp
J	3.S	L1.3	
K	4.A	L1.4	F1 +
L	4.B	L1.5	F1 -
M	4.S	L1.8	
N	5.A	L1.6	F2 +
P	5.B	L1.7	F2 -
R	5.S	L1.18	
S	6.A	L1.9	FC cw
T	6.B	L1.11	FC ccw
U	6.S	L1.10	FC com
V	7.A	L1.12	fbk
W	7.B	L1.13	fbk
X	7.S	L1.14	
Y	8.A	L1.15	Ls
Z	8.B	L1.16	Ls
a	8.S	L1.17	
b	9.A		
c	9.B		
d	9.S		

**Cable M (vacuum side)**

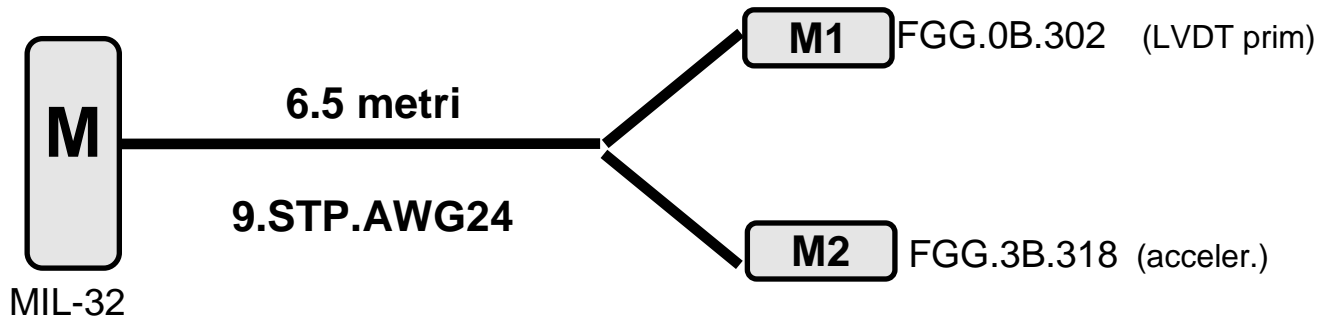

Fase di Taglio e Spelatura
Data:
Operatore/i:
Reel: <i>old cable T of BS tower</i>

Fase di Crimpaggio e Labeling
Data:
Operatore/i:
Tempo impiegato (ore):

Fase di Controllo Qualita'
Data:
Operatore/i:

Fase di Lavaggio e Storage
Data:
Operatore/i:

**Note:**  
 Rifatto ex-novo ad ottobre 2014. Per lo schema del vecchio cavo K vedere la versione v2.  
 - obtained by the former T cable of BS tower cabling.

MIL-32 contacts	conductors	LEMO contacts	Contact description
A	1.A	M1.1	Lp
B	1.B	M1.2	Lp
C	1.S	n.c.	
D	2.A		
E	2.B		
F	2.S		
G	3.A	M2.1	Lp
H	3.B	M2.2	Lp
J	3.S	M2.3	
K	4.A	M2.4	F1 +
L	4.B	M2.5	F1 -
M	4.S	M2.8	
N	5.A	M2.6	F2 +
P	5.B	M2.7	F2 -
R	5.S	M2.18	
S	6.A	M2.9	FC cw
T	6.B	M2.11	FC ccw
U	6.S	M2.10	FC com
V	7.A	M2.12	fbk
W	7.B	M2.13	fbk
X	7.S	M2.14	
Y	8.A	M2.15	Ls
Z	8.B	M2.16	Ls
a	8.S	M2.17	
b	9.A		
c	9.B		
d	9.S		

**Cable N (vacuum side)**

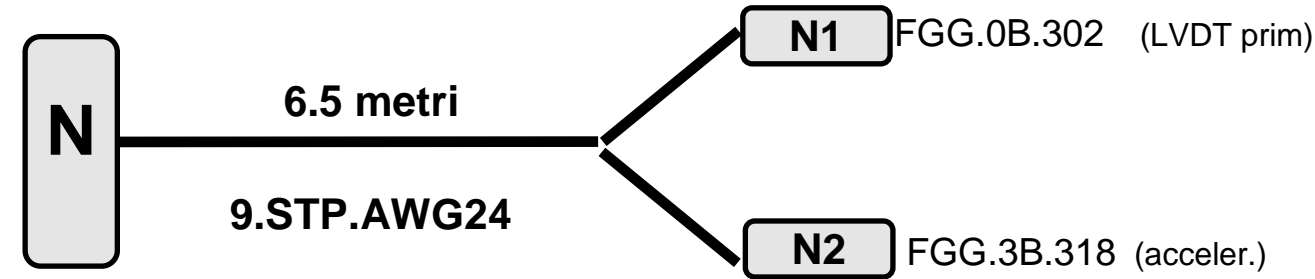

MIL-32

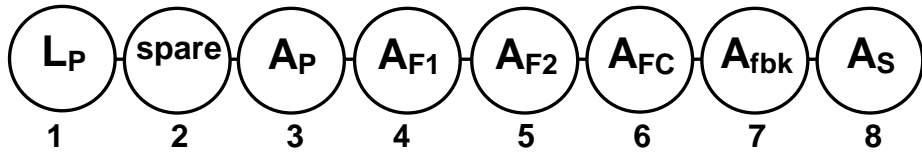

Fase di Taglio e Spelatura
Data:
Operatore/i:
Reel: <i>old cable S of NE tower</i>

Fase di Crimpaggio e Labeling
Data:
Operatore/i:
Tempo impiegato (ore):

Fase di Controllo Qualita'
Data:
Operatore/i:

Fase di Lavaggio e Storage
Data:
Operatore/i:

**Note:**  
 Rifatto ex-novo a novembre 2014. Per lo schema del vecchio cavo N vedere la versione v2.  
 - obtained by the former S cable of NE tower cabling.

MIL-32 contacts	conductors	LEMO contacts	Contact description
A	1.A	N1.1	Lp
B	1.B	N1.2	Lp
C	1.S	n.c.	
D	2.A		
E	2.B		
F	2.S		
G	3.A	N2.1	Lp
H	3.B	N2.2	Lp
J	3.S	N2.3	
K	4.A	N2.4	F1 +
L	4.B	N2.5	F1 -
N	4.S	N2.8	
P	5.A	N2.6	F2 +
R	5.B	N2.7	F2 -
S	5.S	N2.18	
T	6.A	N2.9	FC cw
U	6.B	N2.11	FC ccw
V	6.S	N2.10	FC com
W	7.A	N2.12	fbk
X	7.B	N2.13	fbk
Y	7.S	N2.14	
Z	8.A	N2.15	Ls
a	8.B	N2.16	Ls
	8.S	N2.17	

**Cable O (vacuum side)**

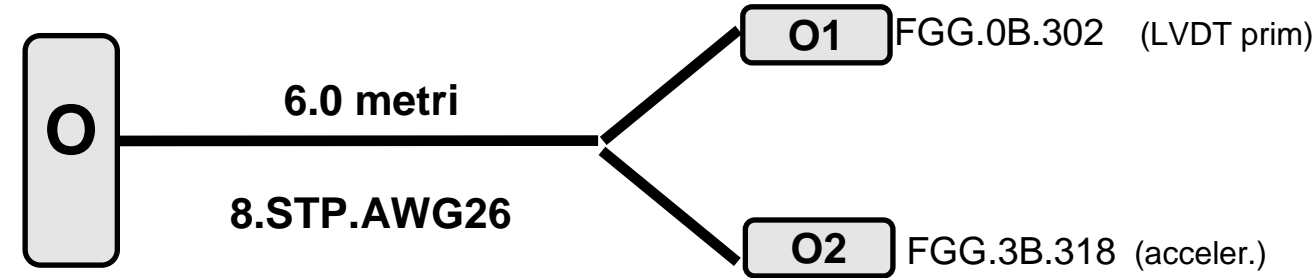

MIL-32

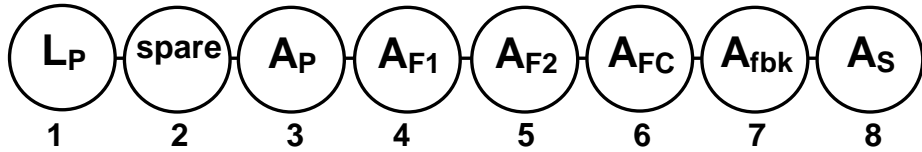

Fase di Taglio e Spelatura
Data:
Operatore/i:
Reel: <i>old cable F of NI tower</i>

Fase di Crimpaggio e Labeling
Data:
Operatore/i:
Tempo impiegato (ore):

Fase di Controllo Qualita'
Data:
Operatore/i:

Fase di Lavaggio e Storage
Data:
Operatore/i:

**Note:**  
 Rifatto ex-novo a novembre 2014. Per lo schema del vecchio cavo O vedere la versione v2.  
 - obtained by the former F cable of NI tower cabling.

MIL-32 contacts	conductors	LEMO contacts	Contact description
A	1.A	O1.1	Lp
B	1.B	O1.2	Lp
C	1.S	n.c.	
D	2.A		
E	2.B		
F	2.S		
G	3.A	O2.1	Lp
H	3.B	O2.2	Lp
J	3.S	O2.3	
K	4.A	O2.4	F1 +
L	4.B	O2.5	F1 -
N	4.S	O2.8	
N	5.A	O2.6	F2 +
P	5.B	O2.7	F2 -
R	5.S	O2.18	
S	6.A	O2.9	FC cw
T	6.B	O2.11	FC ccw
U	6.S	O2.10	FC com
V	7.A	O2.12	fbk
W	7.B	O2.13	fbk
X	7.S	O2.14	
Y	8.A	O2.15	Ls
Z	8.B	O2.16	Ls
a	8.S	M2.17	



## Cable P (vacuum side)

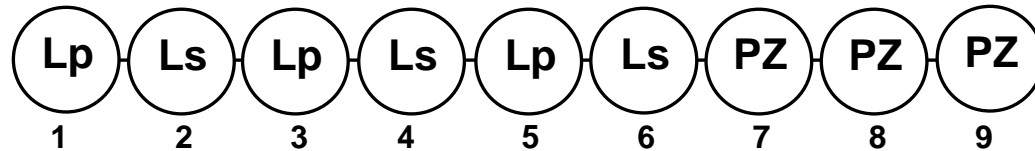
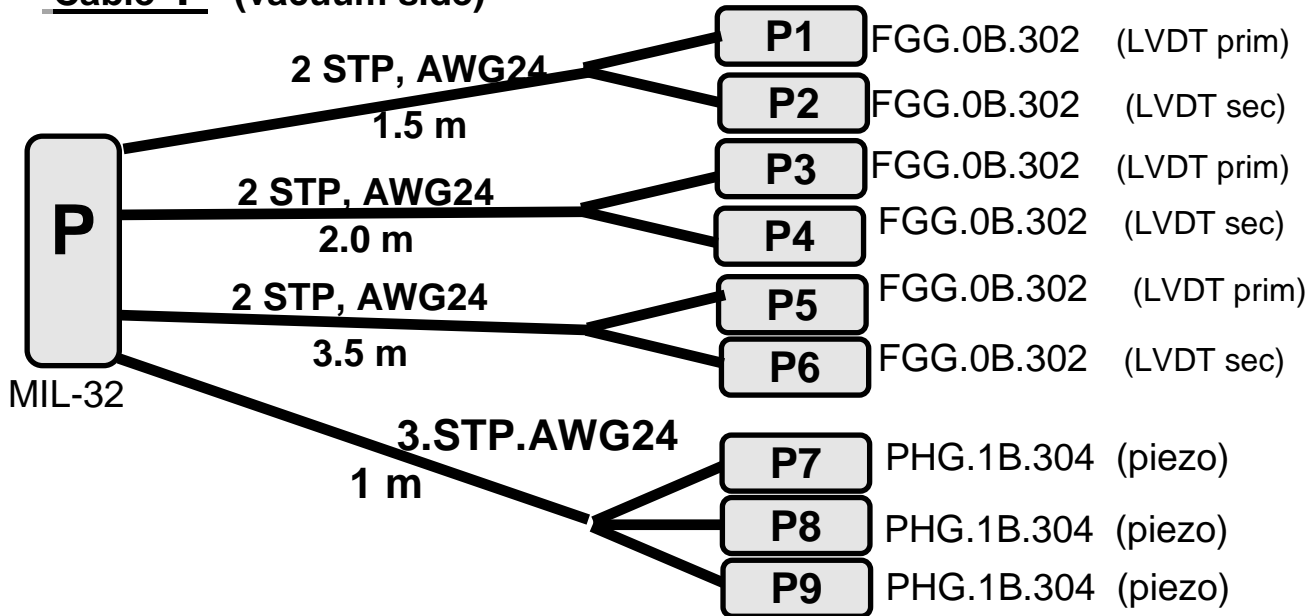

### Cutting and Stripping phase

Data: Nov 2014

Operatore/i:

Bobina di provenienza: *spezzoni*

### Crimping and Labeling phase

Data: Nov 2014

Operatore/i:

Tempo impiegato (ore):

### Quality Control phase

Data: Nov 2014

Operatore/i:

### Cleaning and Storage phase

Data: Nov 2014

Operatore/i:

### Notes:

Diramare opportunamente, considerando che gli LVDT sono disposti a 120 gradi lungo i piedi dell'IP.

MIL-32 contacts	conductors	LEMO contacts	contact description
A	1.A	P1.1	Lp
B	1.B	P1.2	Lp
C	1.S	n.c.	
D	2.A	P2.3	Ls
E	2.B	P2.4	Ls
F	2.S	n.c.	
G	3.A	P3.5	Lp
H	3.B	P3.6	Lp
J	3.S	n.c.	
K	4.A	P4.7	Ls
L	4.B	P4.8	Ls
M	4.S	n.c.	
N	5.A	P5.1	Lp
P	5.B	P5.2	Lp
R	5.S	n.c.	
S	6.A	P6.1	Ls
T	6.B	P6.2	Ls
U	6.S	n.c.	
V	7.A	P7.1	inner conductor intermediate shield outer shield
W	7.B	P7.2	
X	7.S n.c.	P7.3 P7.4	
Y	8.A	P8.1	inner conductor intermediate shield outer shield
Z	8.B	P8.2	
a	8.S n.c.	P8.3 P8.4	
b	9.A	P9.1	inner conductor intermediate shield outer shield
c	9.B	P9.2	
d	9.S n.c.	P9.3 P9.4	

**cable R** (vacuum side)

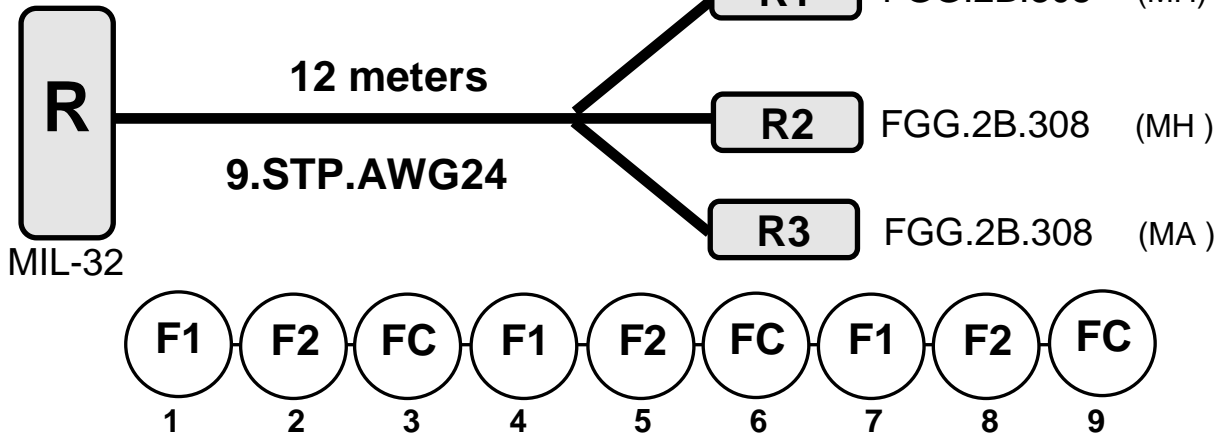

Cutting and Stripping phase
Date:
Operator:
Reel: <i>old cable S of NE tower</i>

Crimping and Labeling phase
Date:
Operator:
Duration (hours):

Quality Control phase
Date:
Operator:

Cleaning and Storage phase
Date:
Operator:

Notes:
- obtained by the former S cable of NE tower cabling.
Rifatto ex-novo a Novembre 2014. Per lo schema del vecchio cavo R vedere la versione v2.
<b>Diramare di <u>30 cm</u>;</b>

MIL-32 contacts	conductors	LEMO contacts	contact description
A	1.A	R1.1	F1 +
B	1.B	R1.2	F1 -
C	1.S	n.c.	
D	2.A	R1.3	F2 +
E	2.B	R1.4	F2 -
F	2.S	n.c.	
G	3.A	R1.5	FC cw
H	3.B	R1.6	FC ccw
J	3.S	R1.7	FC com
K	4.A	R2.1	F1 +
L	4.B	R2.2	F1 -
M	4.S	n.c.	
N	5.A	R2.3	F2 +
P	5.B	R2.4	F2 -
H	5.S	n.c.	
S	6.A	R2.5	FC cw
T	6.B	R2.6	FC ccw
U	6.S	R2.7	FC com
V	7.A	R3.1	F1 +
W	7.B	R3.2	F1 -
X	7.S	n.c.	
Y	8.A	R3.3	F2 +
Z	8.B	R3.4	F2 -
a	8.S	n.c.	
b	9.A	R3.5	FC cw
c	9.B	R3.6	FC ccw
d	9.S	R3.7	FC com

**cable S** (vacuum side)

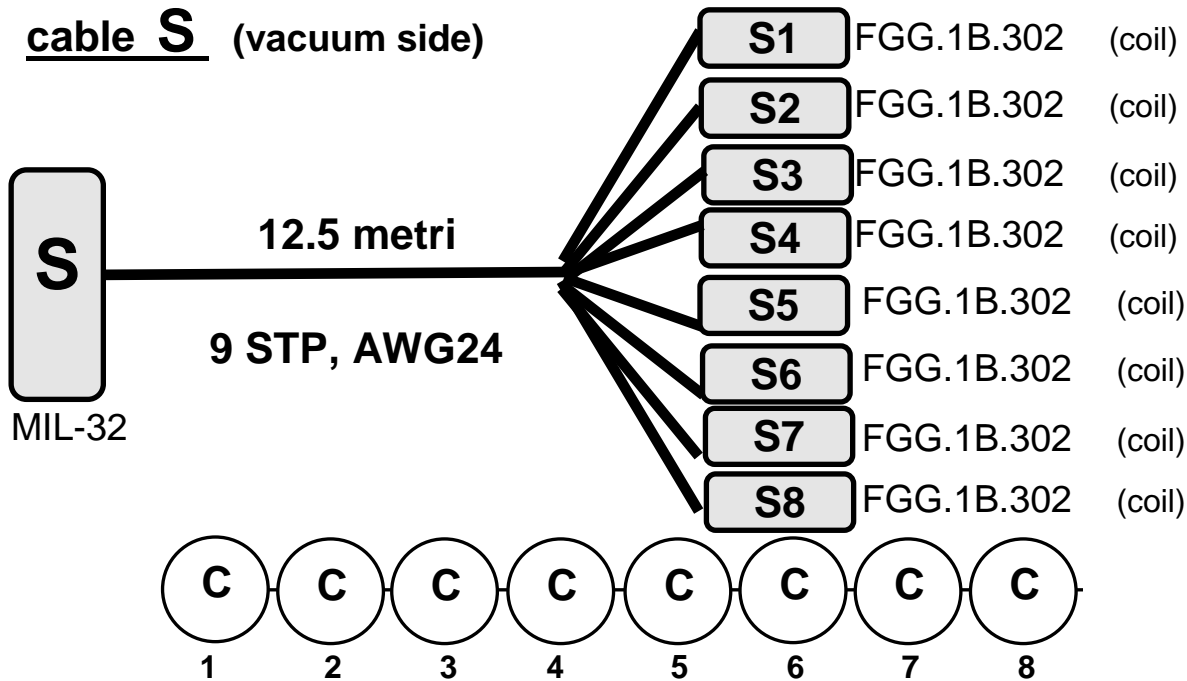

Cutting and Stripping phase	
Date:	
Operator:	
Reel:	<i>old cable F of NI tower</i>

Crimping and Labeling phase	
Date:	
Operator:	
Duration (hours):	

Quality Control phase	
Date:	
Operator:	

Cleaning and Storage phase	
Date:	
Operator:	

**Notes:**  
 - obtained by the former F cable of NI tower cabling.  
 Rifatto ex-novo a Novembre 2014. Per lo schema del vecchio cavo S vedere la versione v2.  
**Diramare di 30 cm;**

MIL-32 contacts	conductors	LEMO contacts	contact description
A	1.A	S1.1	C +
B	1.B	S1.2	C -
C	1.S	n.c.	
D	2.A	S2.1	C +
E	2.B	S2.2	C -
F	2.S	n.c.	
G	3.A	S3.1	C +
H	3.B	S3.2	C -
J	3.S	n.c.	
K	4.A	S4.1	C +
L	4.B	S4.2	C -
M	4.S	n.c.	
N	5.A	S5.1	C +
P	5.B	S5.2	C -
R	5.S	n.c.	
S	6.A	S6.1	C +
T	6.B	S6.2	C -
U	6.S	n.c.	
V	7.A	S7.1	C +
W	7.B	S7.2	C -
X	7.S	n.c.	
Y	8.A	S8.1	C +
Z	8.B	S8.2	C -
a	8.S	n.c.	
b	9.A		
c	9.B		
d	9.S		

**cable T** (vacuum side)

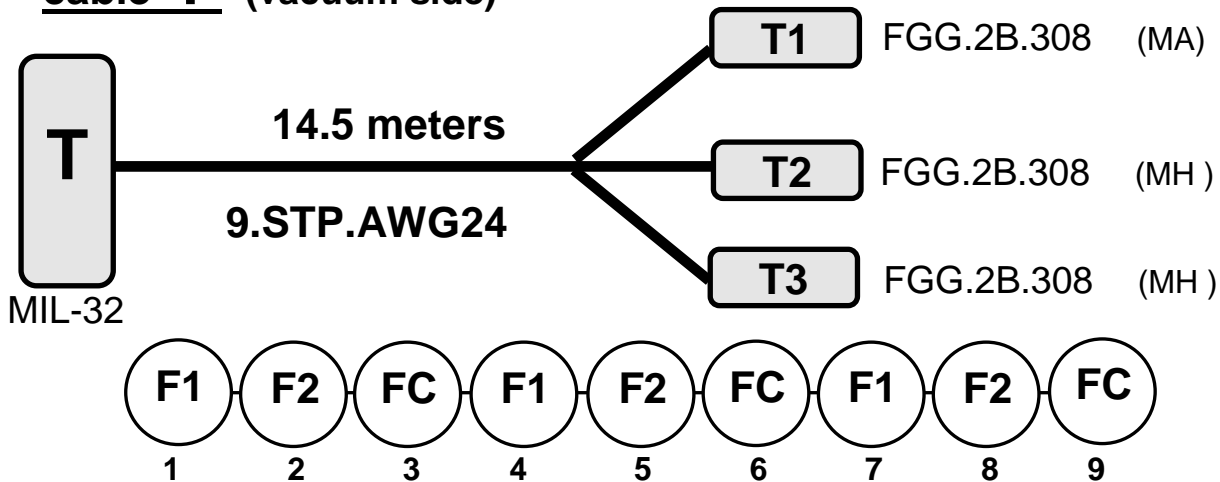

Cutting and Stripping phase
Date:
Operator:
Reel: <i>old cable V of WI tower</i>

Crimping and Labeling phase
Date:
Operator:
Duration (hours):

Quality Control phase
Date:
Operator:

Cleaning and Storage phase
Date:
Operator:

Notes:
- obtained by the former V cable of WI
Diramare T1 di 120cm e poi scorciarlo di 100cm;

MIL-32 contacts	conductors	LEMO contacts	contact description
A	1.A	T1.1	F1 +
B	1.B	T1.2	F1 -
C	1.S	n.c.	
D	2.A	T1.3	F2 +
E	2.B	T1.4	F2 -
F	2.S	n.c.	
G	3.A	T1.5	FC cw
H	3.B	T1.6	FC ccw
J	3.S	T1.7	FC com
K	4.A	T2.1	F1 +
L	4.B	T2.2	F1 -
M	4.S	n.c.	
N	5.A	T2.3	F2 +
P	5.B	T2.4	F2 -
H	5.S	n.c.	
S	6.A	T2.5	FC cw
T	6.B	T2.6	FC ccw
U	6.S	T2.7	FC com
V	7.A	T3.1	F1 +
W	7.B	T3.2	F1 -
X	7.S	n.c.	
Y	8.A	T3.3	F2 +
Z	8.B	T3.4	F2 -
a	8.S	n.c.	
b	9.A	T3.5	FC cw
c	9.B	T3.6	FC ccw
d	9.S	T3.7	FC com